

Sears

***owners
manual***

**MODEL NO.
113.228000
LATHE ONLY**

**MODEL NO.
113.228160
LATHE WITH MOTOR**

Serial
Number 3339 P0647

Model and serial
number may be found
under belt guard.
You should record both
model and serial number
in a safe place for
future use.

CAUTION:

Read **GENERAL** and
ADDITIONAL SAFETY
INSTRUCTIONS
carefully

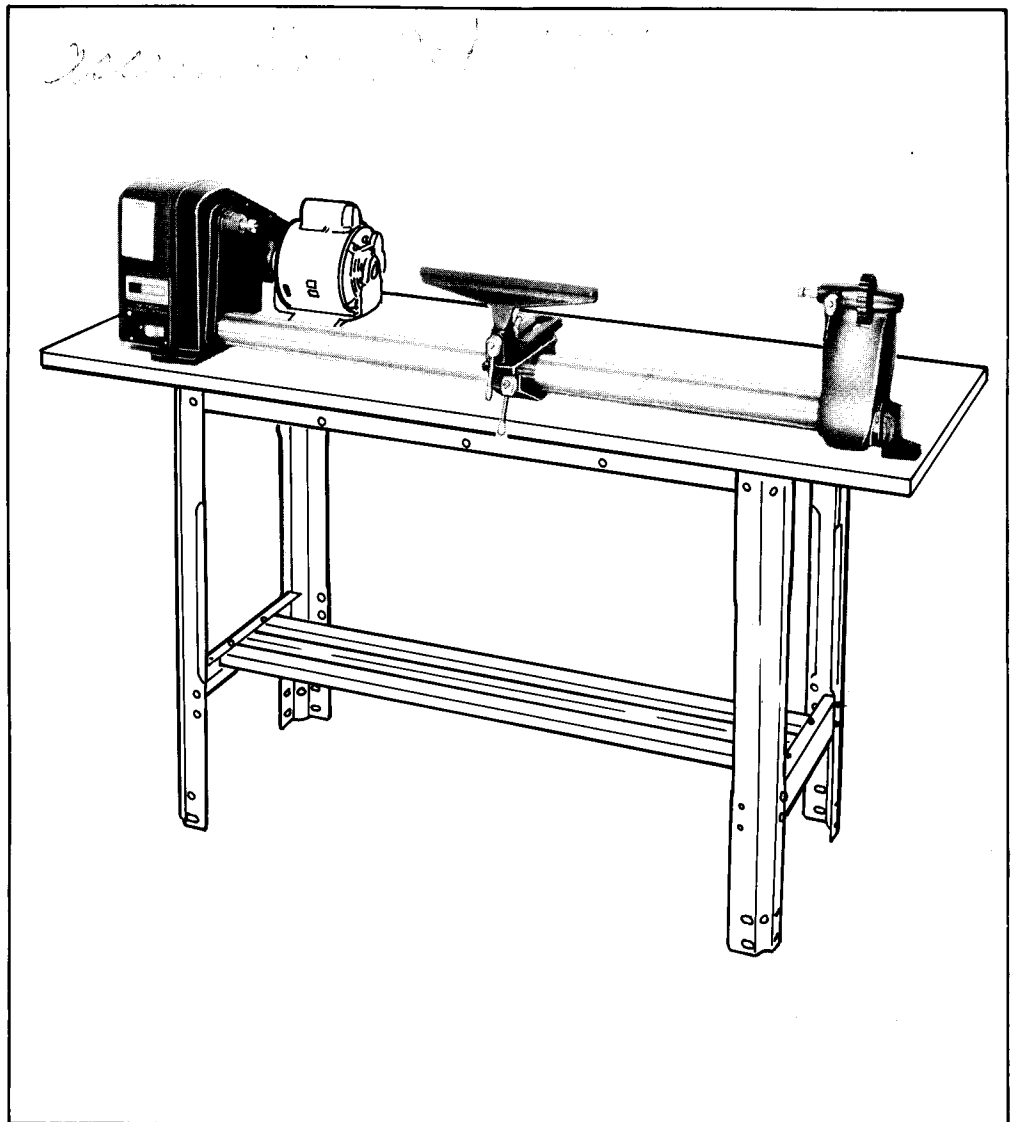

Sears

CRAFTSMAN®

**12-INCH
WOOD-TURNING LATHE**

- ***assembly***
- ***operating***
- ***repair parts***

Sold by SEARS, ROEBUCK AND CO., Chicago, IL. 60684 U.S.A.

FULL ONE YEAR WARRANTY ON CRAFTSMAN WOOD LATHE

If within one year from the date of purchase, this Craftsman Wood Lathe fails due to a defect in material or workmanship, Sears will repair it, free of charge.

WARRANTY SERVICE IS AVAILABLE BY SIMPLY CONTACTING THE NEAREST SEARS STORE OR SERVICE CENTER THROUGHOUT THE UNITED STATES.

This warranty gives you specific legal rights, and you may also have other rights which vary from state to state.

SEARS, ROEBUCK AND CO., Dept. 698/731A, Sears Tower, Chicago, IL 60684

general safety instructions for power tools

1. KNOW YOUR LATHE

Read and understand owner's manual and labels affixed to the tool. Learn its application and limitations as well as its specific potential hazards peculiar to this tool.

2. GROUND THE LATHE

This Lathe is equipped with an approved 3-conductor cord and a 3-prong grounding type plug to fit the proper grounding type receptacle. The green conductor in the cord is the grounding wire. Never connect the green wire to a live terminal.

3. KEEP GUARDS IN PLACE

— in working order, and in proper adjustment and alignment.

4. REMOVE ADJUSTING KEYS AND WRENCHES

Form habit of checking to see that keys and adjusting wrenches are removed from tool before turning it on.

5. KEEP WORK AREA CLEAN

Cluttered areas and benches invite accidents. Floor must not be slippery due to wax or sawdust.

6. AVOID DANGEROUS ENVIRONMENT

Don't use power tools in damp or wet locations or expose them to rain. Keep work area well lighted. Provide adequate surrounding work space.

7. KEEP CHILDREN AWAY

All visitors should be kept a safe distance from work area.

8. MAKE WORKSHOP KID-PROOF

— with padlocks, master switches, or by removing starter keys.

9. USE PROPER SPEED

The Lathe will do the job better and safer when operated at the proper speed.

10. USE RIGHT TOOL

Don't force tool or attachment to do a job for which it was not designed.

11. WEAR PROPER APPAREL

Do not wear loose clothing, gloves, neckties or jewelry (rings; wristwatches) to get caught in moving parts. NONSLIP footwear is recommended. Wear protective hair covering to contain long hair. Roll long sleeves above the elbow.

12. USE SAFETY GOGGLES (Head Protection)

Wear safety goggles (must comply with ANSI Z87.1) at all times. Everyday eyeglasses only have impact resistant lenses, they are NOT safety glasses. Also, use face or dust mask if cutting operation is dusty, and ear protectors (plugs or muffs) during extended periods of operation.

13. SECURE WORKPIECE

Mount workpiece securely between centers.

14. DON'T OVERREACH

Keep proper footing and balance at all times.

15. MAINTAIN TOOLS WITH CARE

Keep tools sharp and clean for best and safest performance. Follow instructions for lubricating and changing accessories.

16. DISCONNECT YOUR LATHE

before servicing; when changing accessories or attachments.

17. AVOID ACCIDENTAL STARTING

Make sure switch is in "OFF" position before plugging in.

18. USE RECOMMENDED ACCESSORIES

Consult this owner's manual for recommended accessories. Follow the instructions that accompany the accessories. The use of improper accessories may cause hazards.

19. NEVER STAND ON LATHE

Serious injury could occur if the Lathe tips over.

Do not store materials such that it is necessary to stand on the tool to reach them.

20. CHECK DAMAGED PARTS

Before further use of the Lathe, a guard or other part that is damaged should be carefully checked to ensure that it will operate properly and perform its intended function. Check for alignment of moving parts, binding of moving parts, breakage of parts, mounting, and any other conditions that may affect its operation. A guard or other part that is damaged should be properly repaired or replaced.

21. DIRECTION OF FEED

Apply cutting tool to the workpiece against the direction of spindle rotation.

22. NEVER LEAVE LATHE RUNNING ATTENDED

Turn power "OFF". Don't leave Lathe until it comes to a complete stop.

additional safety instructions for wood turning lathes

Safety is a combination of operator common sense and alertness at all times when the Lathe is being used.

WARNING: FOR YOUR OWN SAFETY, DO NOT ATTEMPT TO OPERATE YOUR LATHE UNTIL IT IS COMPLETELY ASSEMBLED AND INSTALLED ACCORDING TO THE INSTRUCTIONS . . . AND UNTIL YOU HAVE READ AND UNDERSTAND THE FOLLOWING:

- | | PAGE |
|--|------|
| 1. General Safety Instructions | 2 |
| 2. Getting to Know Your Lathe | 13 |
| 3. Basic Lathe Operation | 15 |
| 4. Maintenance | 19 |
5. The Lathe and motor must be bolted down to a stand or workbench for stability.
6. Protection: Eyes, Hands, Face, Ears, Body
- Wear safety goggles that comply with ANSI Z87.1-1968, and a face shield if operation is dusty. Wear ear plugs or muffs during extended periods of operation.
 - When turning between centers or on the faceplate, always rough-out "out of round" workpieces at slow speed. Running the Lathe too fast, so that it vibrates, could cause the workpiece to be thrown from the Lathe . . . or the turning tool to be jerked from your hands.
 - Always revolve the workpiece by hand before turning on the motor. If the workpiece strikes the tool rest, it could split and be thrown out of the Lathe.
 - Do not allow the turning tool to "bite" into the workpiece which could result in splitting of the workpiece or the workpiece being thrown from the Lathe. Always position the tool rest above the centerline of the Lathe for spindle turning. Do not apply the turning tool to the workpiece below the level of the tool rest.
 - Do not run the Lathe in the wrong direction. This could cause the turning tool to be thrown from your hands. The Lathe must run in a direction so that the workpiece turns toward you.
 - Before attaching a workpiece to the faceplate always "rough it out" to as "true round" as possible. This will minimize vibration while turning.

Always fasten the workpiece securely to the faceplate.

Failure to perform these set-up operations could cause the workpiece to be thrown from the Lathe.
 - Avoid awkward hand positions, where a sudden slip could cause a hand to move into the workpiece.
 - Remove all loose knots before installing workpiece between centers or on the faceplate.
 - Never leave the Lathe work area with the power on before the Lathe has come to a complete stop, or without removing and storing the switch key.

- Never operate the Lathe with protective cover on the unused shaft end of the motor removed.
- Hang your turning tools on the wall toward the tail-stock end of the Lathe. Do not lay them on the bench so that you must reach over the revolving workpiece to select them.
 - Keep firm hold and control of the turning tool at all times. Special caution must be exercised when knots or voids are exposed to the turning tool.
 - Note the following **DANGER** label which appears on the front of the belt guard.

DANGER

FOR YOUR OWN SAFETY:

READ AND UNDERSTAND THE OWNER'S MANUAL BEFORE OPERATING MACHINE:

- WEAR SAFETY GOGGLES PER ANSI Z87.1 AND FACE SHIELD IF OPERATION IS DUSTY.
- DO NOT WEAR GLOVES, NECKTIES, OR LOOSE CLOTHING. TIE BACK LONG HAIR.
- BE POSITIVE ALL LOCKS ARE TIGHT BEFORE OPERATING MACHINE.
- TURN WORKPIECE BY HAND BEFORE APPLYING POWER TO DETERMINE IF IT CLEARS THE TOOL REST OR OTHER MACHINE PARTS.
- ROUGH OUT FACEPLATE WORKPIECES BEFORE INSTALLING ON FACEPLATE TO AVOID EXCESSIVE VIBRATION AND POSSIBLE INJURY.
- DO NOT MOUNT SPLIT OR CHECKED WORKPIECE OR ONE CONTAINING KNOT.
- ALWAYS USE LOWEST SPEED WHEN STARTING A NEW WORKPIECE, USING FACEPLATE OR TURNING BETWEEN CENTERS, TO MINIMIZE POTENTIAL INJURY.

- Think Safety.
- Complete hand sanding of between-centers or faceplate mounted workpieces BEFORE removing from the lathe. Do not exceed the speed used for the last cutting operation performed on the workpiece, in accordance with the speed chart.
- NEVER attempt to remount a faceplate turning to the faceplate for any reason. NEVER attempt to remount a between-centers turning if the original centers in the turning have been altered or removed. BE POSITIVE the lathe is set at the lowest speed if remounting a between-centers turning with non-altered original centers.
- Use extra caution in mounting a between-centers or spindle turning to the faceplate, or a faceplate turning to between-centers, for subsequent operations. BE POSITIVE the lathe is set at the lowest speed before turning ON.
- NEVER mount a workpiece that contains any splits, checks, or loose knots to a faceplate or between centers.
- Do not perform any operation when hand holding the workpiece. Do not mount a reamer, milling cutter, wire wheel, buffing wheel, or a drill bit to the headstock spindle.
- Use the drill chuck accessory in the tail stock only. Do not mount any drill that extends more than 6 inches beyond chuck jaws.

additional safety instructions for wood turning lathes

WARNING: DO NOT ALLOW FAMILIARITY (GAINED FROM FREQUENT USE OF YOUR MACHINE) TO BECOME COMMONPLACE. ALWAYS REMEMBER THAT A CARELESS FRACTION OF A SECOND IS SUFFICIENT TO INFLICT SEVERE INJURY.

WARNING: THE FOUR STEP LATHE AND MOTOR PULLEYS FURNISHED ARE DESIGNED TO RUN THE LATHE AT THE CORRECT SPEEDS WHEN USED WITH A 1725 R.P.M. MOTOR. DO NOT USE A 3450 R.P.M. MOTOR TO INCREASE THE SPEED BECAUSE IT COULD BE DANGEROUS.



The operation of any power tool can result in foreign objects being thrown into the eyes, which can result in severe eye damage. Always wear safety goggles complying with ANSI Z87.1 (shown on Package) before commencing power tool operation. Safety Goggles are available at Sears retail or catalog stores.

motor specifications and electrical requirements

This Lathe is designed to use a 1725 RPM motor only. Do not use any motor that runs faster than 1725 RPM. It is wired for operation on 110-120 volts, 60 Hz., alternating current. **IT MUST NOT BE CONVERTED TO OPERATE ON 230 VOLTS. EVEN THOUGH SOME OF THE RECOMMENDED MOTORS ARE DUAL VOLTAGE.**

THESE MOTORS HAVE BEEN FOUND TO BE ACCEPTABLE FOR USE ON THIS TOOL.

HP	RPM	VOLTS	CATALOG NO.
1/3	1725	110-120	1282
1/2	1725	110-120	1278
1/2	1725	110-120	1279
1/2	1725	110-120	1289

CAUTION: Do not use blower or washing machine motors or any motor with an automatic reset overload protector as their use may be hazardous.

CONNECTING TO POWER SOURCE OUTLET

This machine must be grounded while in use to protect the operator from electric shock.

Plug power cord into a 110-120V properly grounded type outlet protected by a 15-amp. dual element time delay or Circuit-Saver fuse or circuit breaker.

If you are not sure that your outlet is properly grounded, have it checked by a qualified electrician.

WARNING: DO NOT PERMIT FINGERS TO TOUCH THE TERMINALS OF PLUGS WHEN INSTALLING OR REMOVING THE PLUG TO OR FROM THE OUTLET.

WARNING: IF NOT PROPERLY GROUNDED THIS POWER TOOL CAN INCUR THE POTENTIAL HAZARD OF ELECTRICAL SHOCK. PARTICULARLY WHEN USED IN DAMP LOCATIONS IN PROXIMITY TO PLUMBING. IF AN ELECTRICAL SHOCK OCCURS THERE IS THE POTENTIAL OF A SECONDARY HAZARD SUCH AS YOUR HANDS CONTACTING THE CUTTING TOOL.

If power cord is worn or cut, or damaged in any way, have it replaced immediately.

If your unit is for use on less than 150 volts it has a plug that looks like below.

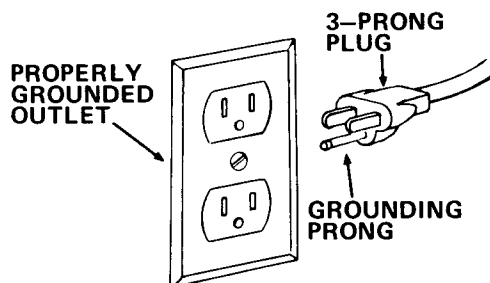

This power tool is equipped with a 3-conductor cord and grounding type plug which has a grounding prong, approved by Underwriters' Laboratories. The ground conductor has a green jacket and is attached to the tool housing at one end and to the ground prong in the attachment plug at the other end.

This plug requires a mating 3-conductor grounded type outlet as shown.

If the outlet you are planning to use for this power tool is of the two prong type **DO NOT REMOVE OR ALTER THE GROUNDING PRONG IN ANY MANNER.** Use an adapter as shown and always connect the grounding lug to known ground.

It is recommended that you have a qualified electrician replace the TWO prong outlet with a properly grounded THREE prong outlet.

An adapter as shown below is available for connecting plugs to 2-prong receptacles. The green grounding lug extending from the adapter must be connected to a permanent ground such as to a properly grounded outlet box.

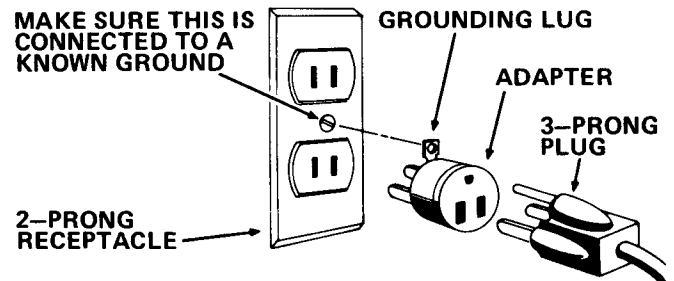

NOTE: The adapter illustrated is for use only if you already have a properly grounded 2-prong receptacle.

The use of any extension cord will cause some loss of power. To keep this to a minimum and to prevent overheating and motor burn-out, use the table below to determine the minimum wire size (A.W.G.) extension cord. Use only 3 wire extension cords which have 3-prong grounding type plugs and 3-pole receptacles which accept the tools plug.

Extension Cord Length	Wire Size A.W.G.
Up to 100 Ft.	16
100 - 200 Ft.	14
200 - 400 Ft.	10

CHECK MOTOR ROTATION

WARNING: FOR YOUR OWN SAFETY, MAKE SURE PLUG IS NOT CONNECTED TO POWER SOURCE OUTLET WHEN CHANGING MOTOR ROTATION.

The motor must rotate **CLOCKWISE** when viewed from the shaft end to which you will mount the pulley. (See page 12.) If it does not, change the direction according to the instructions furnished with the motor.

unpacking and checking contents

CONTENTS

UNPACKING AND CHECKING CONTENTS	6
ASSEMBLY	7
Mounting Lathe and motor on recommended Craftsman bench	7
Spur and cup center installation	9
Off and on switch	10
Check motor rotation	12
GETTING TO KNOW YOUR WOOD LATHE	13
Belt guard lock	13
Index pin	13
Spindle lock hole	13
Tool rest lock	13
Tool rest base lock	13
Handwheel	13

Tailstock ram lock	13
Tailstock lock	13
On - off switch	13
Spur center and cup center (aligning centers)	14
Tailstock	14
Speed chart	15
BASIC LATHE OPERATION	15
Changing speeds	15
Spindle turning	16
Indexing	18
MAINTENANCE	19
LUBRICATION	19
RECOMMENDED ACCESSORIES	21
REPAIR PARTS	22

TOOLS NEEDED

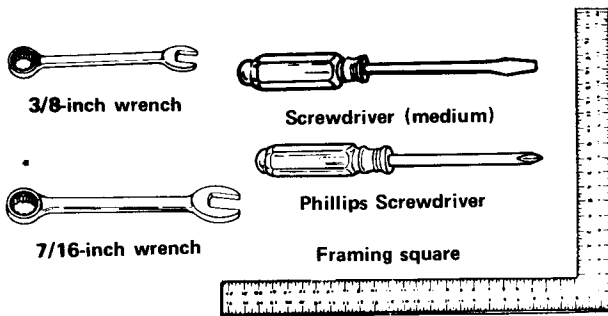

Model 113.228000 Wood Lathe is shipped complete in one carton (without motor, or bench). The V-Belt and motor pulley are furnished.

Model 113.228160 Wood Lathe is shipped complete in one carton and includes a Motor.

Separate all parts from packing materials and check each one with the "Table of Loose Parts" to make certain all items are accounted for, before discarding any packing material.

If any parts are missing, do **not** attempt to assemble the lathe plug in the power cord or turn the switch on until the missing parts are obtained and are installed correctly.

Using a 7/16" wrench, remove the wood blocks attached to the Lathe. Save the nuts, bolts and washers, you will need for attaching the Lathe to the bench.

Remove the protective oil that is applied to the bed. Use any ordinary household type grease and spot remover.

CAUTION: Never use gasoline, naphtha or similar highly volatile solvents.

Apply a coat of automobile wax to the bed. Wipe all parts thoroughly with a clean dry cloth.

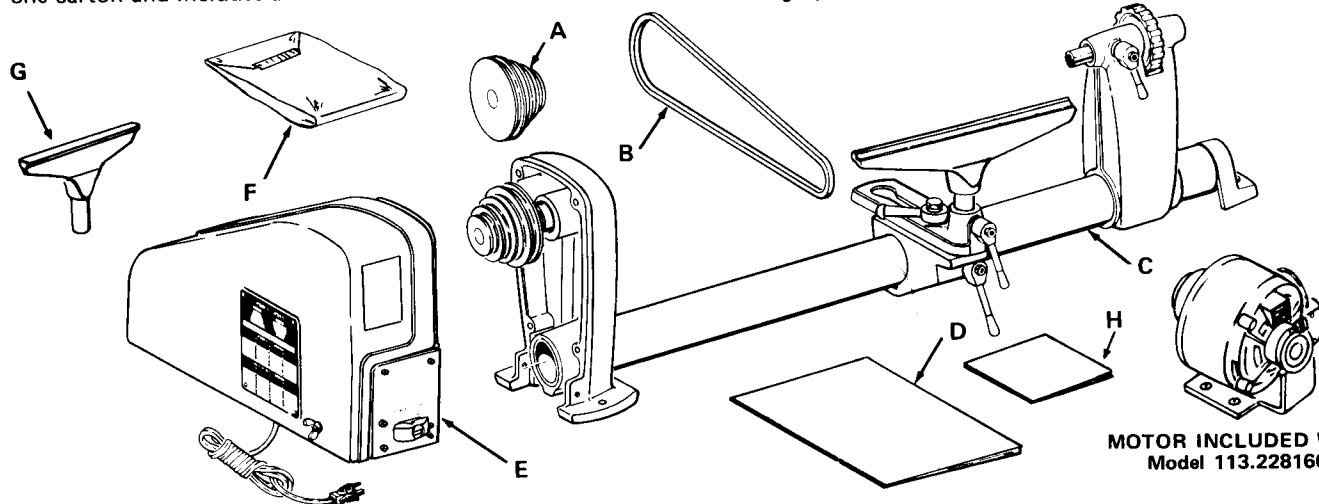

Item	Table of Loose Parts	Qty.
A	Motor Pulley	1
B	Belt, "Vee" 1/2 x 37	1
C	Wood Turning Lathe	1
D	Owner's Manual	1
E	Belt Guard Assembly	1
F	Loose Parts Bag - Part No. 70046	
	Containing the following:	
	Wrench, Hex 5/32	1
	Wrench, Hex 3/16	1
	Screw, Type 23 Pan 10-32 x 3/8	4
	Nut, Hex 3/4-16	1
	Spur, Center	1

Item	Table of Loose Parts	Qty.
	Cup, Center	1
	Point, Center	2
	Lockwasher Ext. Tooth No. 10	4
	Key, Switch	1
	Clamp Cord	2
	Bolt Rd. Hd. Carriage 1/4-20 x 1-3/4	4
	Washer 17/64 x 47/64 x 1/16	4
	Nut Hex 1/4-20	4
	Screw Pan Hd. Ty. A No. 8 x 1/2	4
G	6" Tool Rest	1
H	Booklet, How To Operate Your Craftsman Lathe	1

assembly

MOUNTING LATHE AND MOTOR ON WORKBENCH

1. Drill six $\frac{3}{8}$ " holes in your bench according to the diagram to the right. **NOTE:** Make sure the top of your bench is positioned so that you don't drill into the legs or rail underneath.

When mounting to a Sears workbench, side overhang of top at headstock end should be 5" from leg portion of stand. (Front overhang of top should remain 1- $\frac{1}{8}$ ").

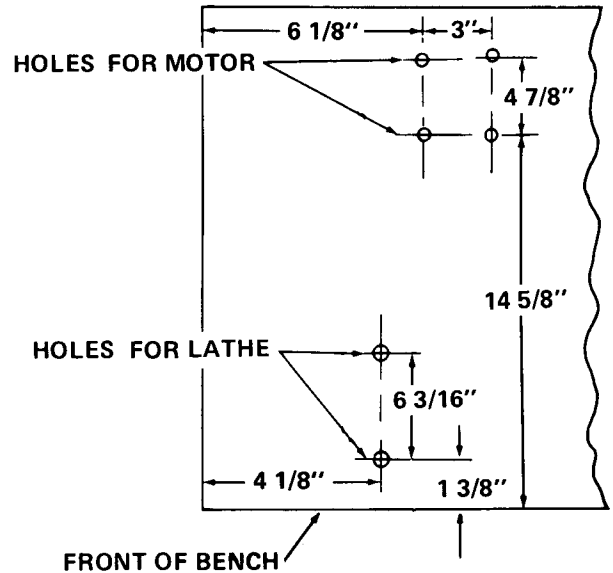

LOCATION OF MOUNTING HOLES

NOTE: To attach your Lathe to the bench, use the bolts, nuts and washer you removed when unpacking.

2. Position Lathe on bench and insert two bolts through holes in headstock but do not screw on the nuts.
3. Position the Lathe so that the bed is parallel to the front of the bench. Check the foot. If the bottom of the foot is not flat on the surface of the bench, loosen the screw in the foot, tap the screw to loosen the locknut inside. Turn the foot so it is flat on the bench and tighten the screw.
4. Mark the location on the bench of the hole in foot.
5. Remove the Lathe and drill a $\frac{3}{8}$ " hole to attach the foot.
6. Position the Lathe and insert the bolts from the top. Place a flat washer, a lockwasher and a nut on the bolts and tighten the nuts.
7. Position the motor over the mounting holes. **NOTE:** When using a Craftsman double shaft motor, make sure the $\frac{5}{8}$ " dia. shaft is to the left when facing the front of the Lathe. For motors with a $\frac{1}{2}$ " diameter shaft see Step 15.

NOTE: Motor is included with Model 113.228160.

NOTE: The ventilation holes in the motor should NOT face upward as sawdust can collect inside the motor. If necessary, loosen the two motor base clamp screws and rotate the motor. Then, tighten the clamp screws.

8. Find four 1- $\frac{3}{4}$ " carriage bolts, flat washers and nuts from among the loose parts (see illustration).
9. Insert the bolts from the top. Place a flat washer and a nut on the bolts but do not tighten the nuts at this time.

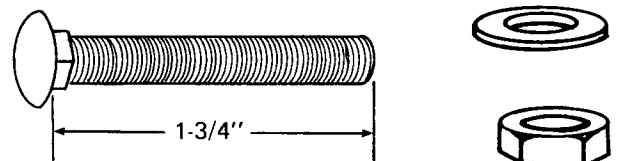
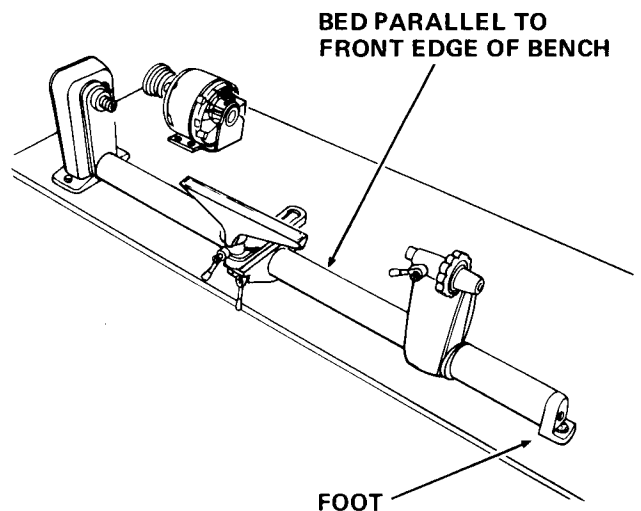

assembly

10. Remove the headstock pulley using the 5/32" set-screw wrench.
11. Find four pan head thread cutting screws 3/8" long and four lockwashers from among the loose parts. Attach the belt guard with these screws and lockwashers. The arrows in this illustration show the location of the screws.

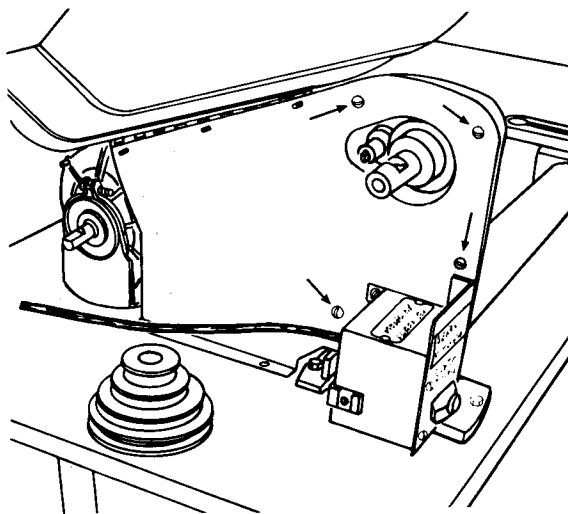
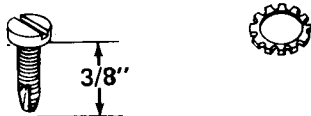

12. Place the headstock pulley onto the headstock shaft as shown. Position it so that the end of the pulley is flush with the end of the lathe spindle.
13. Place the motor pulley on the motor shaft so that the small diameter is approximately 1/16" away from the motor.
14. **NOTE:** When installing the pulley on a 5/8" diameter motor shaft, make sure that the 3/16" square key furnished with your motor is in place. Then tighten the setscrew with a 5/32" setscrew wrench.

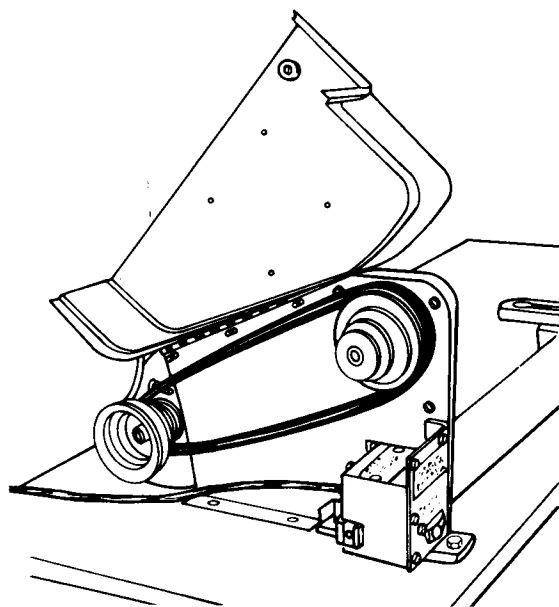

15. **NOTE:** When installing the pulley on a 1/2" diameter motor shaft, make sure that the adapter sleeve and 3/16" square key furnished with your motor are in place. Then tighten the setscrew with a 5/32" setscrew wrench.
16. Place the belt on the pulleys and slide the motor toward the rear of workbench until all the slack is removed from the belt. **NOTE:** 1/2 inch deflection of belt under moderate pressure applied between the two pulleys is adequate tension. Tighten only two of the motor mounting bolts using a 7/16" wrench.

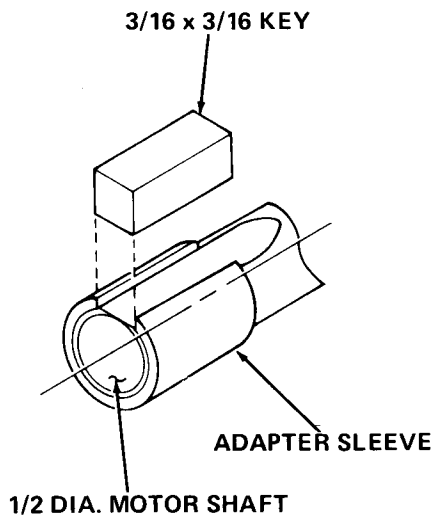

17. Place a straightedge such as a piece of wood, metal or framing square across the pulleys to see if they are in line with each other. If they are, tighten the other two motor mounting bolts. If they are not in line, loosen the two motor bolts and move the motor sideways . . . tighten the bolts.
18. Find four pan head wood screws 1/2" long from among the loose parts.

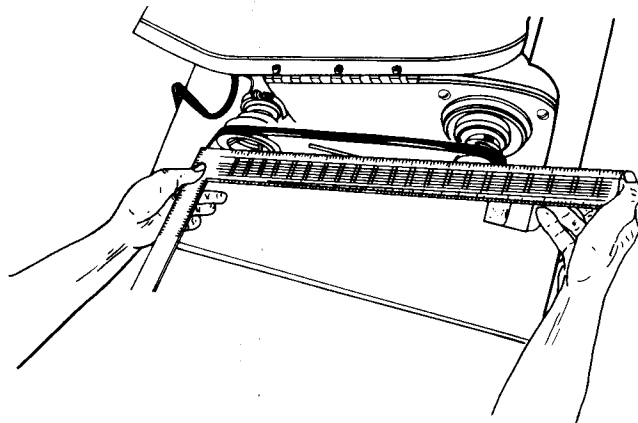
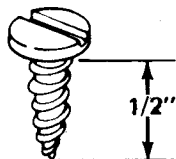

Attach the belt guard plate to the bench with the two screws. Make sure the plate is **PARALLEL** to the belt.

19. Plug motor cord into outlet on back of switch box. **DO NOT** plug motor cord into power source outlet.
20. Position the two cords as shown and clamp them to the table with two cable clamps and 1/2" wood screws from the loose parts bag.
21. Coil up the slack in the cord and tie it with a piece of tape.

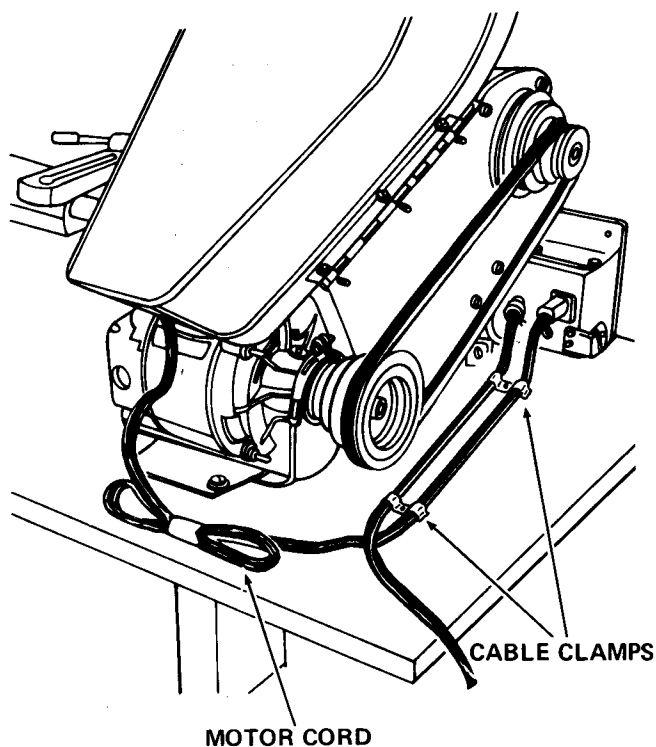

SPUR AND CUP/CENTER INSTALLATION

1. Find a 3/4-16 hex nut among the loose parts and screw onto head stock spindle until finger tight.

3/4-16
HEX NUT

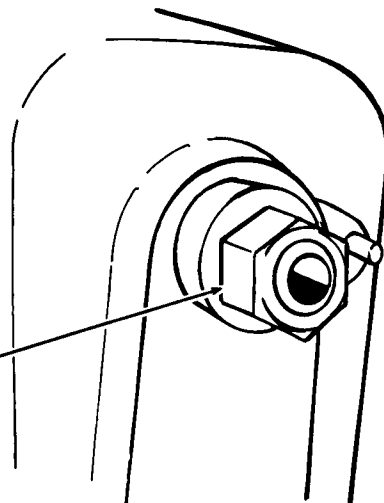

assembly

2. Find two points and a spur and cup center among the loose parts. To insert point into centers, place center between jaws of a vise. Do not tighten vise. Insert point into center and with a hammer and nail gently tap around the base of the point until secure.

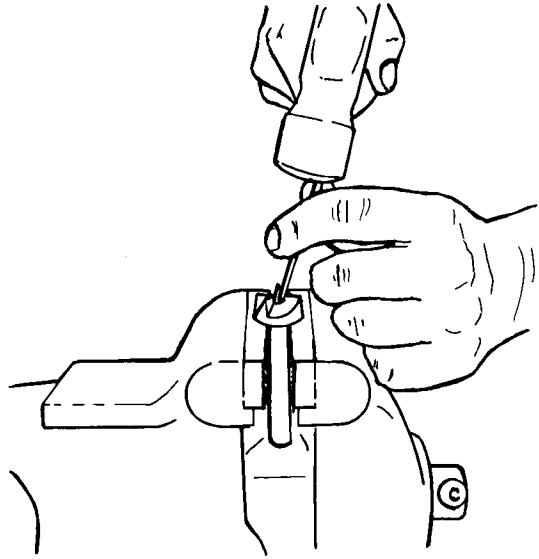

3. Insert spur center into head stock spindle and cup center into tailstock ram. **NOTE:** Do not drive or hammer centers into spindle or ram as removal may be difficult. Use a soft hammer or block of wood and give them a gentle tap.
4. To remove spur center from spindle, hold the spindle pulley with one hand, and, using a wrench or pair of pliers, turn the hex nut counterclockwise until center is ejected.
5. To remove cup center insert a 1/4" wood dowel or brass rod through the hole in the tailstock ram. Hold the center with one hand and tap the dowel or rod with a hammer.

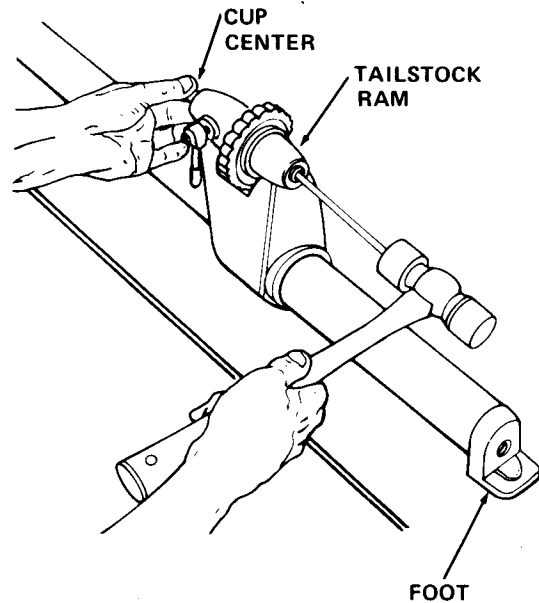

WARNING: DON'T CONNECT POWER CORD TO ELECTRICAL OUTLET IN YOUR SHOP UNTIL YOU ARE READY TO CHECK MOTOR ROTATION.

ON-OFF SWITCH

The On-Off Switch has a locking feature. **THIS FEATURE IS INTENDED TO PREVENT UNAUTHORIZED AND POSSIBLE HAZARDOUS USE BY CHILDREN AND OTHERS.**

1. Insert key into switch.

NOTE: Key is made of yellow plastic.

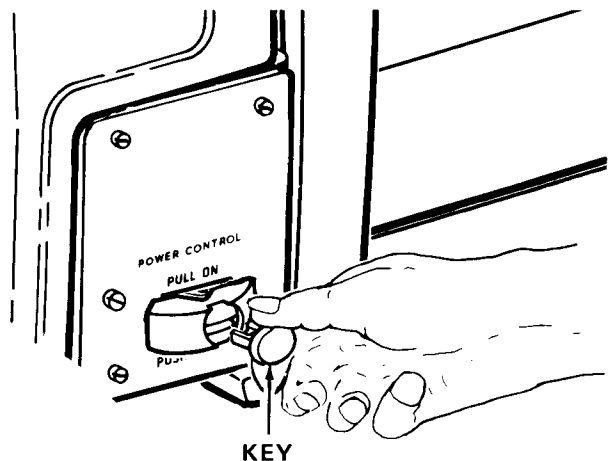

2. To turn Lathe ON . . . INSERT finger under switch lever and pull END of switch out.

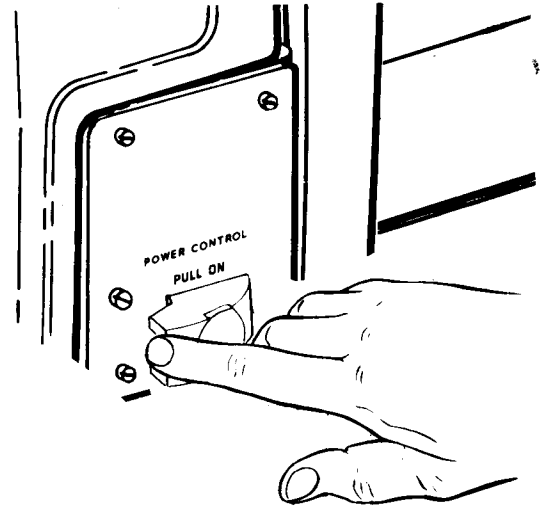

3. To turn Lathe OFF . . . PUSH lever in.

Never leave the Lathe unattended until it has come to a complete stop and you have removed the switch key.

Do not cycle the motor switch on and off rapidly, as this may cause the faceplate or sanding disc to loosen. In the event this should ever occur, stand clear of the face plate or sanding disc until it has come to a complete stop . . . retighten it.

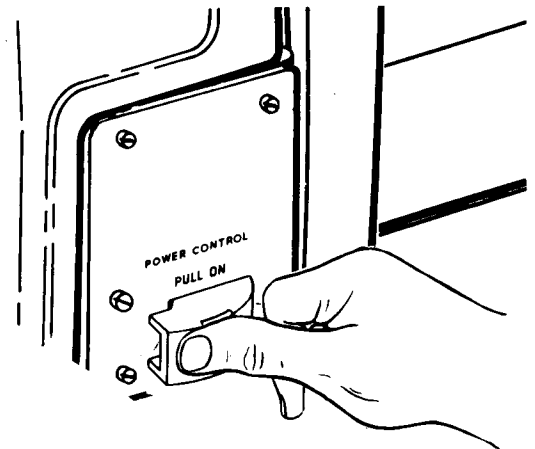

assembly

4. To lock switch in OFF position . . . HOLD switch IN with one hand, REMOVE key with other hand.

WARNING: FOR YOUR OWN SAFETY, ALWAYS LOCK THE SWITCH "OFF". WHEN LATHE IS NOT IN USE . . . REMOVE KEY AND KEEP IT IN A SAFE PLACE . . . ALSO . . . IN THE EVENT OF A POWER FAILURE (ALL OF YOUR LIGHTS GO OUT) TURN SWITCH OFF... LOCK IT AND REMOVE THE KEY. THIS WILL PREVENT THE LATHE FROM STARTING UP AGAIN WHEN THE POWER COMES BACK ON.

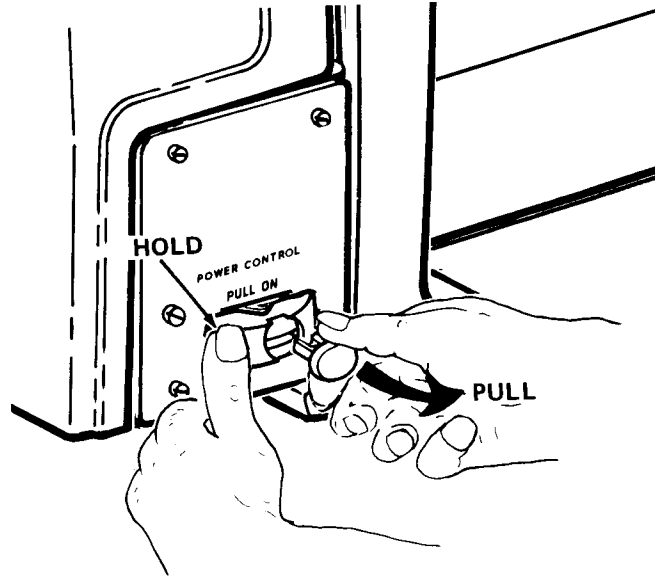

CHECK MOTOR ROTATION

The Lathe must rotate counterclockwise when viewed from the spindle end.

NOTE: Make sure the spur center is removed from the spindle.

1. Plug the Lathe power cord into a properly grounded outlet (See page 4).
2. Stand clear of the Lathe spindle and turn the switch ON. Notice the rotation of the spindle. If it is NOT turning COUNTERCLOCKWISE . . . Remove the Lathe power cord plug from the outlet and change the rotation of the motor according to the directions furnished with the motor.

WARNING: FOR YOUR OWN SAFETY, MAKE SURE PLUG IS NOT CONNECTED TO POWER SOURCE OUTLET WHEN CHANGING MOTOR ROTATION.

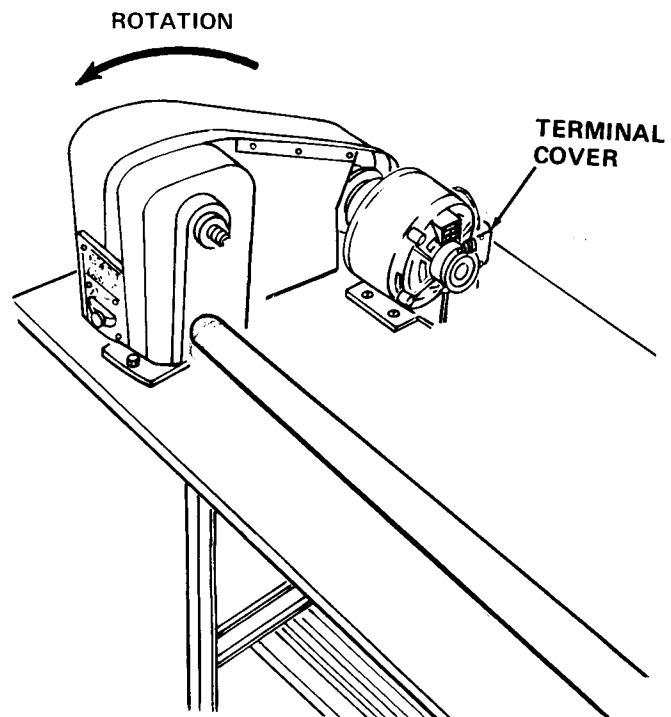

getting to know your wood lathe

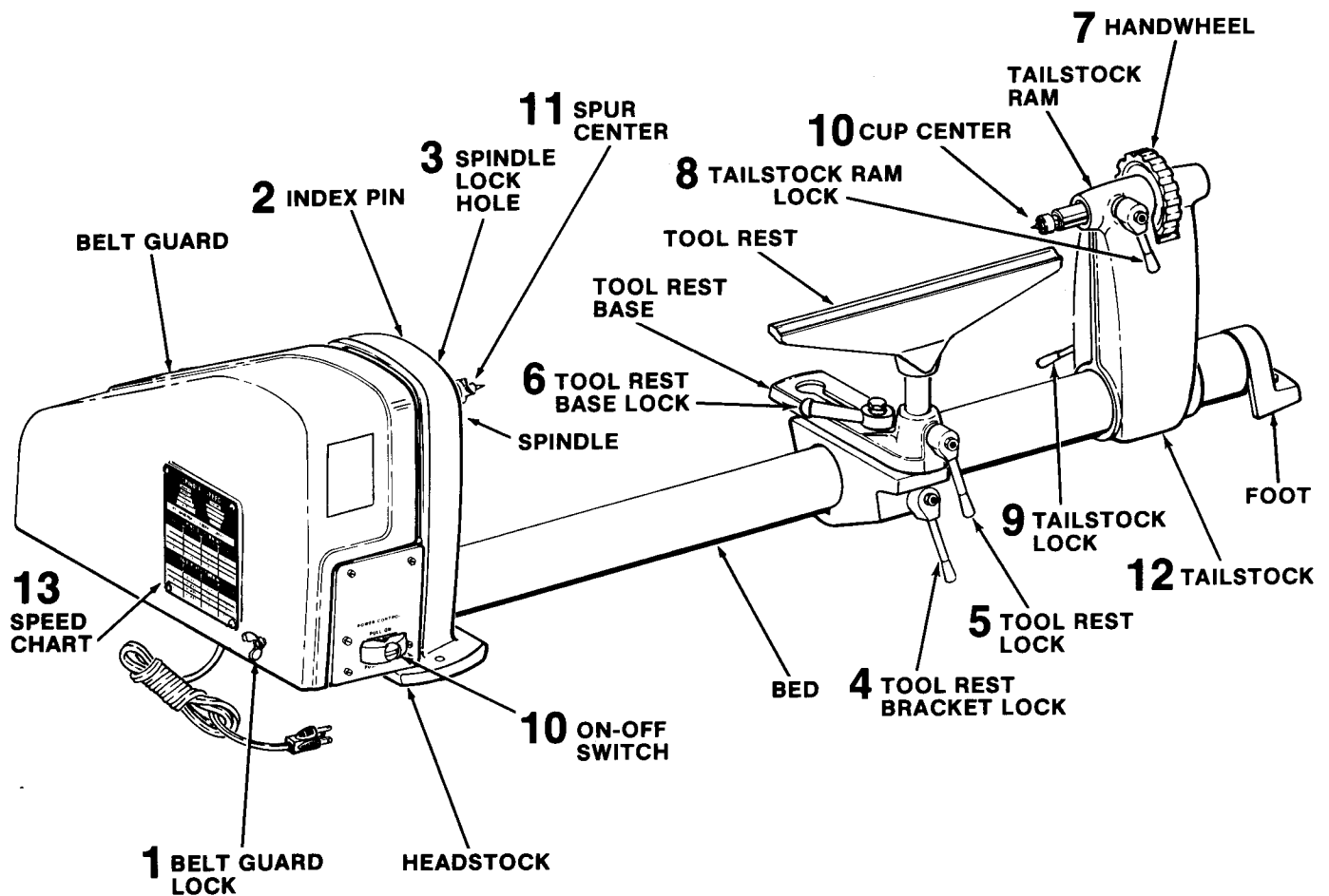

1. **BELT GUARD LOCK** . . . Locks the hinged part of the guard during operation.
2. **INDEX PIN** . . . Engages with the spindle pulley to determine equal spacing for cuts for fluting or reeding, or for dividing face plate work. **DO NOT USE FOR REMOVING FACEPLATES.**
3. **SPINDLE LOCK HOLE** . . . For removing faceplates or sanding discs. Insert a setscrew wrench, large nail or bolt in the hole to hold the spindle while unscrewing faceplate or sanding disc.
4. **TOOL REST BRACKET LOCK** . . . Clamps the tool rest bracket to the bed.
5. **TOOL REST LOCK** . . . Clamp the tool rest to the tool rest base.
6. **TOOL REST BASE LOCK** . . . Clamps the tool rest base to the bed.
7. **HANDWHEEL** . . . Adjusts the tailstock ram.
8. **TAILSTOCK RAM LOCK** . . . Clamps the ram in the tailstock.
9. **TAILSTOCK LOCK** . . . Clamps the tailstock to the bed.
10. **ON-OFF SWITCH** . . . See page 10.

getting to know your wood lathe

- 11. SPUR CENTER AND CUP CENTER . . .** are used for spindle turning and should always be in alignment.

ALIGNING CENTERS

If the centers are not in line as shown, make the following adjustments.

1. Make sure the tailstock and ram are locked when checking for alignment.
2. Loosen the screw in the foot . . . TAP the screw to loosen the locknut inside.
3. Using a 3/16" setscrew wrench, loosen the setscrew on the back of the headstock. The screw is located about 1-3/4" from the bottom.
4. Swing the tailstock so that the two points are in line . . . tighten the setscrew in the headstock and the screw in the end of the tailstock.

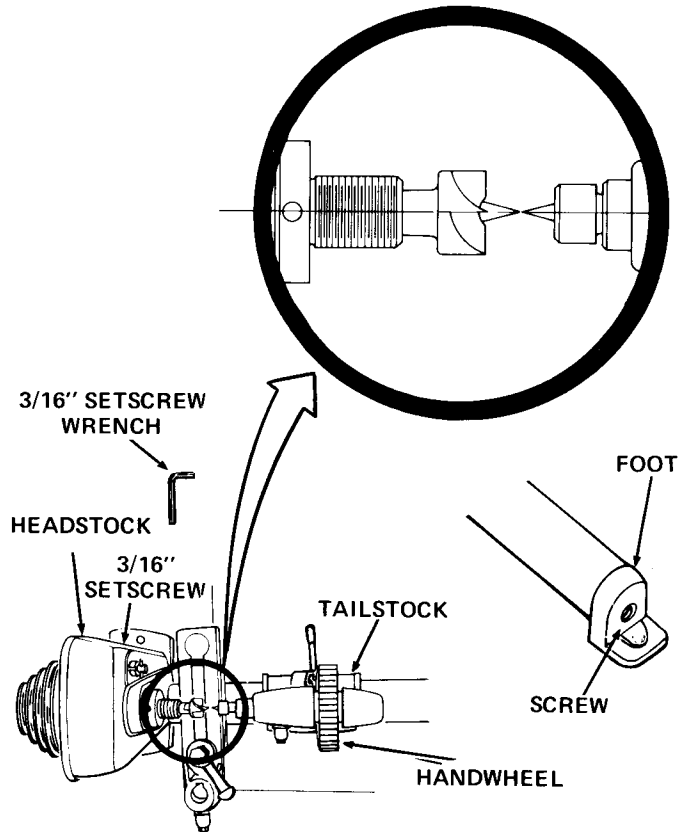

- 12. TAILSTOCK . . .** supports the workpiece for spindle turning.

The tailstock contains a brass screw which bears against the "key" on the underside of the bed. This screw prevents excessive "looseness" (rocking back and forth) of the tailstock.

1. Loosen the locknut using a 7/16" wrench.
2. Tighten the screw moderately against the key, then loosen it about 1/4 turn.

Slide the tailstock along the bed. If it does not stick or bind in any one spot, tighten the nut. If it binds or sticks, loosen the screw only enough so that the tailstock slides smoothly along the bed.

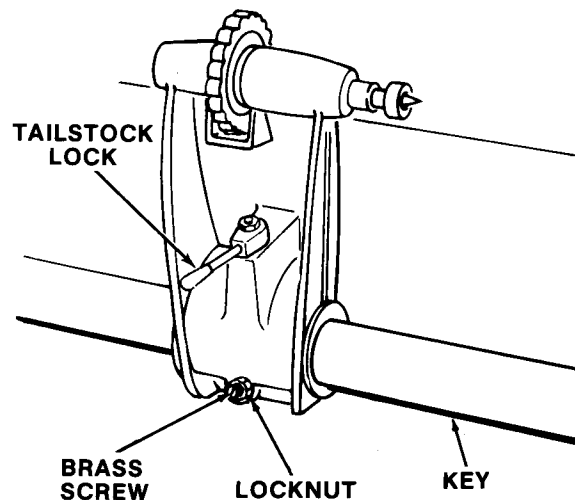

13. SPEED CHART ... Indicates general recommended speeds for various sizes of workpieces.

SPINDLE SPEED	
MOTOR	SPINDLE
	875
	1350
	2250
	3450

RECOMMENDED GENERAL SPEEDS			
SPINDLE TURNING			
SQUARE	LENGTH	ROUGHING	FINISHING
1"	12"	1350	3450
2"	18"	875	2250
3"	27"	875	2250
4"	36"	875	2250

FACE PLATE TURNING			
DIAMETER	THICKNESS	ROUGHING	FINISHING
12"	4" MAX	875	1350
10"	4" MAX	1350	2250
8"	4" MAX	1350	2250
6"	4" MAX	2250	3450

MAXIMUM MOTOR SIZE ½ H.P. 1725 R.P.M.
(SEE OWNER'S MANUAL)

basic lathe operations

CHANGING SPEEDS

The belt is shown positioned on the second steps of the pulleys. This causes the lathe to run 2250 R.P.M.

Suppose you wish to run the lathe slower - say, 1350 R.P.M. You must shift the belt inward.

1. Make sure the power cord is removed from the outlet.
2. With the belt guard raised, rotate the motor pulley **COUNTERCLOCKWISE** with your left hand while pushing on the belt with your right hand.
3. Continue to rotate the pulley while pushing on the belt until it "climbs" down into the third step of the motor pulley.
4. Now rotate the spindle pulley **CLOCKWISE** with your right hand while pushing on the belt with your left hand. The belt will climb up into the third step of the spindle pulley.

To make the lathe go faster, the belt must be shifted outward.

1. Rotate the spindle pulley **CLOCKWISE** with your right hand. Pull on the belt while rotating the pulley until it climbs down into the next smaller step.
2. Now rotate the motor pulley **COUNTERCLOCKWISE** with your left hand while pulling on the belt with your right hand. The belt will climb up into the next larger step.

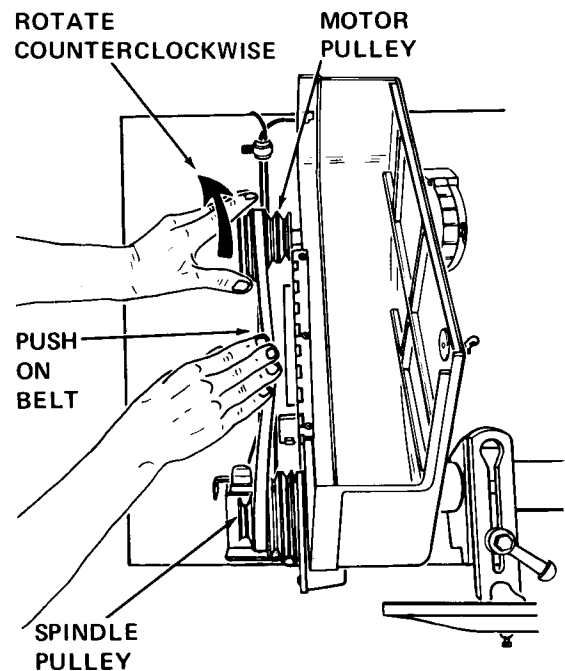

basic lathe operations

SPINDLE TURNING.

If you have never done any amount of wood turning, we suggest that you practice using the various wood turning tools. Start with a small spindle turning.

Be sure to study the "Handbook" which you received with your lathe. It explains and illustrates the correct use of the turning tools, the positioning of the tool rest and other information to help you gain experience.

- 1 Select a piece of wood 2" x 2" x 12".
2. Draw diagonal lines on each end to locate the centers.
3. On one end, make a saw cut approximately 1/16" deep on each diagonal line. This is for the spur center.
4. The other end is for the cup center. Place the point of the cup center on the wood where the diagonal lines cross

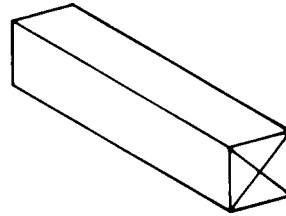

DIAGONAL LINES
ON BOTH ENDS

-
5. Drive the cup center into the wood. Use a wooden mallet or a plastic hammer. If you don't have one, use a steel hammer, but put a piece of wood on the end of the cup center to protect it.
 6. Remove the cup center and drive the spur center into the other end of the wood. Make sure the spurs are in the saw cuts. Remove the spur center.
 7. Make sure the centers and the hole in the spindle and the tailstock ram are clean. Insert the spur center into the headstock and the cup center into the tailstock and tap them in lightly with a piece of wood. Do not drive them in.
 8. Put a drop of oil or wax on the wood where it contacts the cup center. This will lubricate the wood while it is turning.
 9. Place the wood between the centers and lock the tailstock.
 10. Move the cup center into the wood by turning the hand wheel. Make sure that the cup center and spur center are "seated" into the wood in the holes made in steps 5 and 6 above. Rotate the wood by hand while turning the hand wheel.

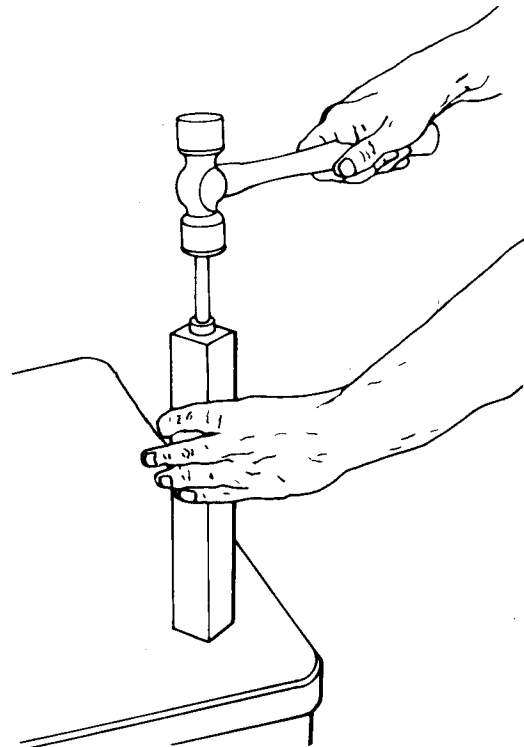

11. Adjust the tool rest approximately 1/8" away from the corners of the wood and 1/8" above the center line. Note the angled position of the tool rest base.

Lock the tool rest base and the tool rest.

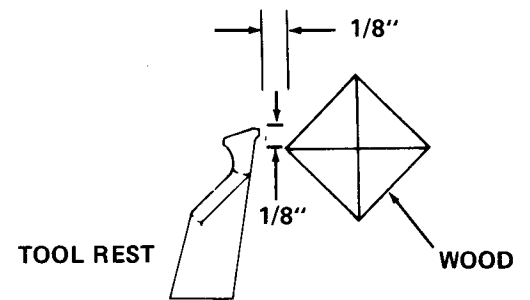

Look at the speed chart. Notice that a 2" square turning up to 18" long should run at 875 R.P.M. for "roughing". Move the V-belt on the pulleys to the slowest speed.

Rotate the wood by hand to make sure that the corners do not strike the tool rest.

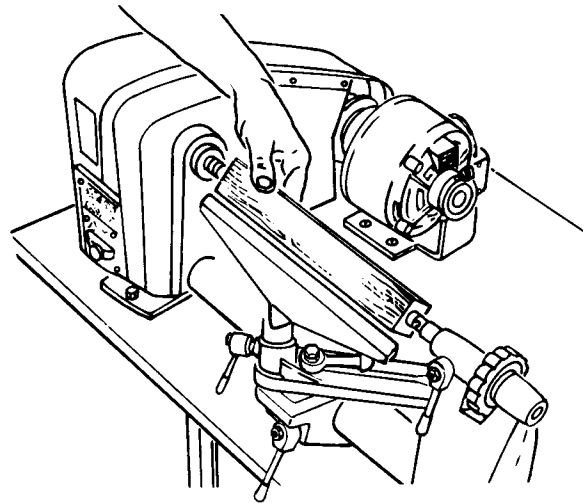

basic lathe operations

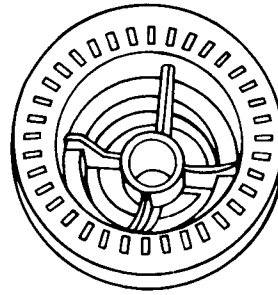

INDEXING

The spindle pulley contains 36 equally spaced holes. The index pin engages with these holes to keep the spindle from turning while you put a mark on the workpiece.

For example: To locate the position of six spokes in a wheel:

1. Pull the index pin outward and turn it so that the small cross pin slips into the slot. This will allow the index pin to engage in one of the holes in the pulley and prevent the spindle from turning.
2. Adjust the tool rest approximately at the centerline and make a mark.
3. Pull out the index pin and slowly rotate the workpiece until the pin slides into the next hole in the pulley.
4. Do this six times and put the next mark on the workpiece. The two marks will be spaced 60° apart. Continue this operation until six spokes are marked 60° apart.
5. Spindle turnings can be divided in the same manner.

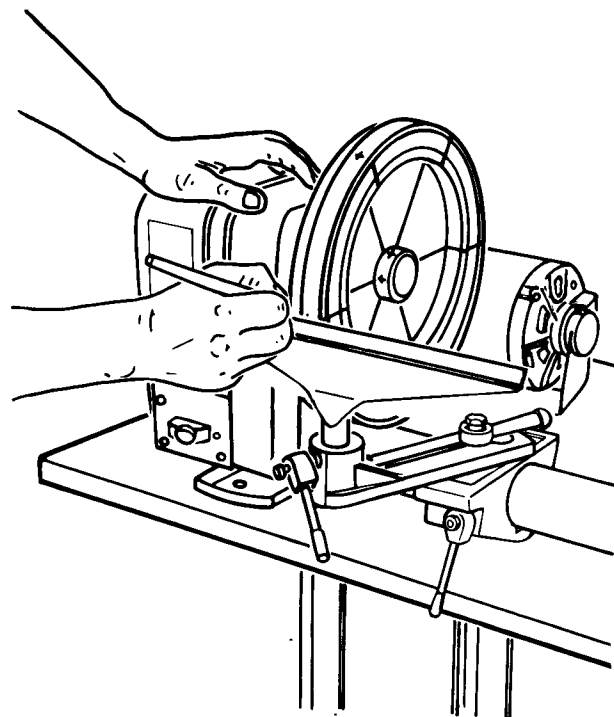
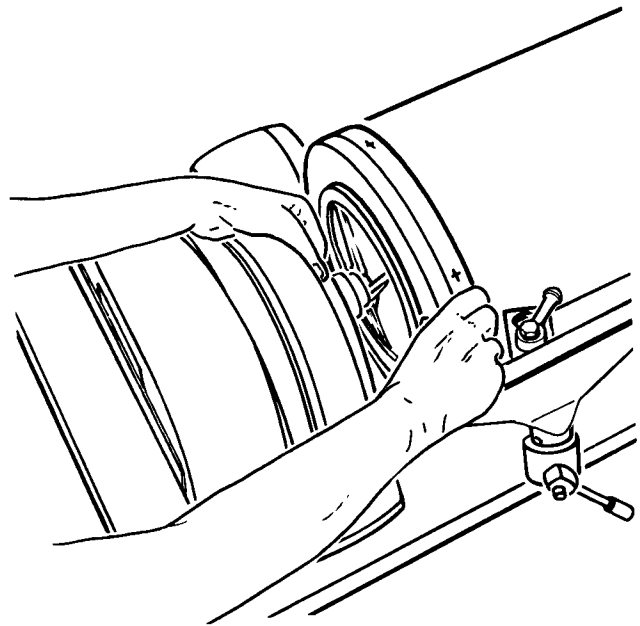

maintenance

WARNING: FOR YOUR OWN SAFETY, TURN SWITCH "OFF" AND REMOVE PLUG FROM POWER SOURCE OUTLET BEFORE MAINTAINING OR LUBRICATING YOUR LATHE.

Frequently blow out any dust that may accumulate inside the motor.

A coat of automobile-type wax applied to the bed will help

to keep the surfaces clean and allow the tool rest and tailstock to move more freely.

If the power cord is worn or cut, or damaged in any way, have it replaced immediately.

For motor maintenance, follow instructions furnished with motor.

WIRING DIAGRAM

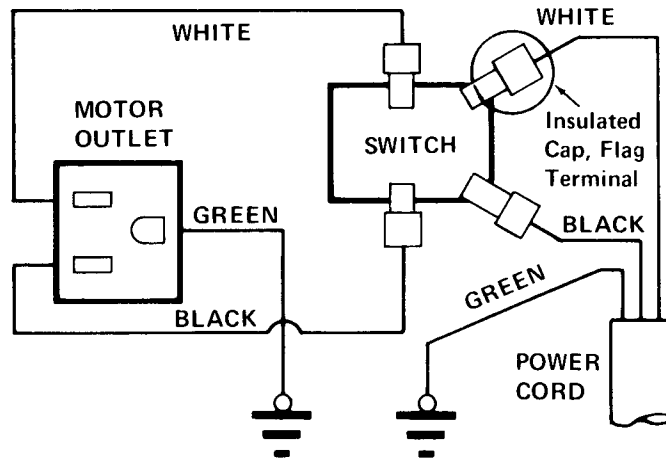

Lubrication

All of the BALL BEARINGS are packed with grease at the factory. They require no further lubrication.

Periodically lubricate the ram in the tailstock with No. 20 or No. 30 engine oil.

For motor lubrication, follow instructions furnished with the motor.

trouble shooting

TROUBLE SHOOTING CHART

TROUBLE	PROBABLE CAUSE	REMEDY
Motor will not run.	<ol style="list-style-type: none">1. Defective On-Off switch. Defective switch cord. Defective switch box receptacle.2. Motor protector open, (only if your motor is equipped with an overload protector).3. Burned out motor	<ol style="list-style-type: none">1. Replace defective parts before using Lathe again.2. Reset protector when motor has cooled.3. Consult Sears Service. Any attempt to repair this motor may create a HAZARD unless repair is done by a qualified service technician. Repair service is available at your nearest Sears Store.
Lathe slows down when turning	<ol style="list-style-type: none">1. V-belt too loose	<ol style="list-style-type: none">1. Adjust belt tension, see Assembly Section.
Tailstock rocks back and forth excessively.	<ol style="list-style-type: none">1. Brass adjusting screw is too loose.	<ol style="list-style-type: none">1. Adjust screw. See Section, "Getting To Know Your Lathe".
Headstock loose on bed.	<ol style="list-style-type: none">1. Setscrew not tight.	<ol style="list-style-type: none">1. Tighten setscrew. See Section, "Getting To Know Your Lathe".
Wood burns at tailstock end.	<ol style="list-style-type: none">1. Cup center too tight or not lubricated.	<ol style="list-style-type: none">1. Back off tailstock ram and lubricate cup center. See Basic Lathe Operation Section, "Spindle Turning."

recommended accessories

RECOMMENDED ACCESSORIES

ITEM	CAT. NO.
Work Bench	(See Catalog)
Motor Pulley (Four Step) 1/2" Bore	9-27921
Motor Pulley (Four Step) 5/8" Bore	9-27922
Drill Chuck 1/2" Capacity with No. 1 M.T. Shank	9-22342
Screw Center with No. 1 M.T. Shank	9-21164
Ball Bearing Center with No. 1 M.T. Shank	9-21122
60° Center with No. 1 M.T. Shank	9-21102
Face Plate, 4" Dia. with 3/4"-16 Thread 9 holes	9-2489
Face Plate, Including Spurs and Screw Center 3" Dia. with 3/4"-16 Thread	9-20912
Sanding Table	9-24922
9" Dia. Sanding Disc Only with 3/4"-16 Thread	9-24906
Turning Tools	(SEE CATALOG)
Draw Bolt with 1/4"-20 Threads	9-21542
Power Tool Know How Handbook	
Radial Saw	9-2917
Table Saw	9-2918
Bowl Turning Toolrest	9-24903
Face Plate 6" with 3/4"-16 Thread 6 holes	9-24904
Copy Crafter	9-24907
Speed Reducer	9-23895
Face Plate 4" dia. with 3/4"-16 Thread Cast Iron, 6 holes	9-23865
Diameter Sizing Gauge	9-24909

The above recommended accessories are current and were available at the time this manual was printed.

repair parts

CRAFTSMAN 12" WOOD-TURNING LATHE MODEL No. 113.228000 & 113.228160

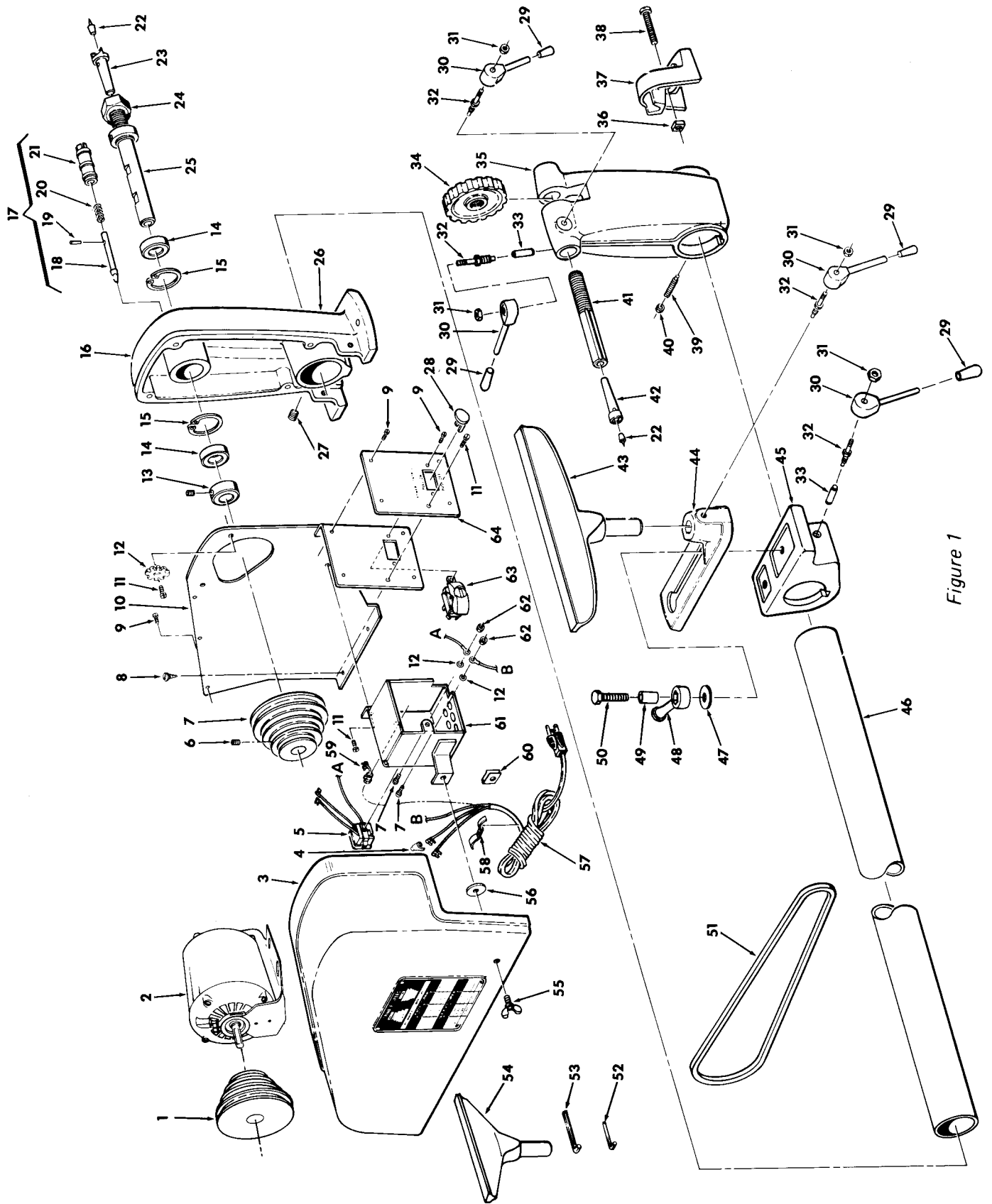

Figure 1

IMPORTANT

Supplement to Owners Manual for the
113.228000 & 113.228160 12-INCH WOOD-TURNING LATHE

THIS SUPPLEMENT INCORPORATES CHANGES TO PARTS LIST SHOWN ON PAGES 22 AND 23.

KEY NUMBERS 31 AND 32 HAVE BEEN REPLACED ON PAGES 22 AND 23 WITH
THE FOLLOWING PARTS:

<u>KEY NO.</u>	<u>PART NO.</u>	<u>DESCRIPTION</u>
31	STD541525	*NUT, LOCK 1/4 - 28
32	56634	STUD, NUT

* STANDARD HARDWARE ITEM-
MAY BE PURCHASED LOCALLY

FORM NO. SP4754

PRINTED IN U.S.A. 11/8

CRAFTSMAN 12" WOOD-TURNING LATHE MODEL No. 113.228000 & 113.228160

Key No.	Part No.	Description	Key No.	Part No.	Description
1	803639	+Pulley	34	56217	Wheel, Hand
2	70047	+Motor (Model 113.22816)	35	70051	Housing, Tailstock
3	70004	Guard Assembly, includes items 55 and 56	36	120399	*Nut Square 5/16-18 x 9/16 x 7/32
4	63467	Cap, Flag Term	37	56213	Foot, Rear
5	60341	Outlet	38	805518	*Screw, Pan. Hd. 5/16-18 x 1-3/4
6	STD 503102	*Screw, Soc. Hd. Set 5/16-18 x 5/16	39	56628	Screw, Slotted Hd. Set 1/4-20 x 1-1/4
7	56170	Pulley, Includes Key No. 6	40	STD 541025	Nut, Hex 1/4-20
8	STD 610805	Screw, Pan Hd. Type A 8 x 1/2	41	56625	Spindle, Tailstock
9	STD 600602	*Screw, Type 23 Pan No. 6-32 x 1/4	42	56190	+No. 1 Morse Taper Cut Center with Point
10	70008	Guard, Plate	43	70016	Rest, Tool
11	STD 600603	*Screw, Type 23 Pan No. 10-32 x 3/8	44	56222	Holder, Tool Rest
12	STD 551210	*Lockwasher, No. 10	45	70049	Clamp, Support
13	56110	Collar with Set Screw	46	56130	Tube Assembly
14	18229	Bearing, Ball	47	60121	Washer, .380 x 1-9/64 x 7/64
15	38884	Ring, Retaining 1-5/8	48	69072	Wrench
16	70014	Headstock	49	69077	Spacer
17	56120	Plunger and Housing Assembly, Complete Consisting of Items 18, 19, 20, and 21	50	STD 523720	Screw, Hex Hd. 3/8-16 x 2
18	56614	Plunger	51	STD 304370	*Belt, "Vee" 1/2 x 37
19	18994	Pin	52	60096	*+Wrench, Hex 5/32
20	38896	Spring	53	30504	*+Wrench, Hex 3/16
21	56613	Housing, Plunger	54	70019	Rest, 6" Tool
22	56619	Point	55	30540	Screw, Wing
23	56180	+No. 1 Morse Taper Spur Center with Point	56	805146	Washer
24	219753	Nut, Hex 3/4-16	57	60271	Cord (w/Plug)
25	56611	Spindle	58	63418	Clamp
26	70006	Headstock Assembly, Complete Consisting of Items 6, 7, 13, 14, 15, 16, 17, 22, 23, 25, and 27	59	37818	Relief, Strain
27	STD 503705	*Screw, Soc. Hd. Set 3/8-16 x 1/2	60	37530	Nut, "U" Clip
28	60256	Key	61	70009	Box, Junction
29	60262	Grip	62	STD 541110	*Nut, Hex No. 10-32
30	70001	Lever, Assembly Lock	63	60267	Switch, Locking
31	STD 541425	Nut, Lock 1/4-20	64	70010	Switch, Panel
32	70052	Nut, Stud	—	70046	Bag of Loose Parts (Not Illustrated)
33	70050	Shoe, Lock	—	SP4052	Booklet-How To Operate Your Craftsman Lathe (Not Illustrated)
			—	70053	Owners, Manual (Not Ills.)

* Standard Hardware Item — May Be Purchased Locally.

† Stock Item — May be secured through the Hardware Department of most Sears Retail Stores or Catalog Order Houses.

NOTE: Shipping and handling charges for standard hardware items (identified by *) such as nuts, screws, washers, etc., make buying these items by mail uneconomical. To avoid shipping and handling charges, you may obtain most of these locally.



**owners
manual**

SERVICE

**MODEL NO.
113.228000
LATHE ONLY**

**MODEL NO.
113.228160
LATHE WITH MOTOR**

**HOW TO ORDER
REPAIR PARTS**

**12-INCH
WOOD-TURNING LATHE**

Now that you have purchased your 12" Wood-Turning Lathe should a need ever exist for repair parts or service, simply contact any Sears Service Center and most Sears, Roebuck and Co. stores. Be sure to provide all pertinent facts when you call or visit.

The model number of your 12" Wood-Turning Lathe will be found on a plate under the belt guard.

**WHEN ORDERING REPAIR PARTS, ALWAYS GIVE THE
FOLLOWING INFORMATION:**

PART NUMBER	PART DESCRIPTION
MODEL NUMBER	NAME OF ITEM
113.228000	12-INCH WOOD
113.228160	TURNING LATHE

All parts listed may be ordered from any Sears Service Center and most Sears stores. If the parts you need are not stocked locally, your order will be electronically transmitted to a Sears Repair Parts Distribution Center for handling.

Sold by SEARS, ROEBUCK AND CO., Chicago, IL. 60684 U.S.A.