

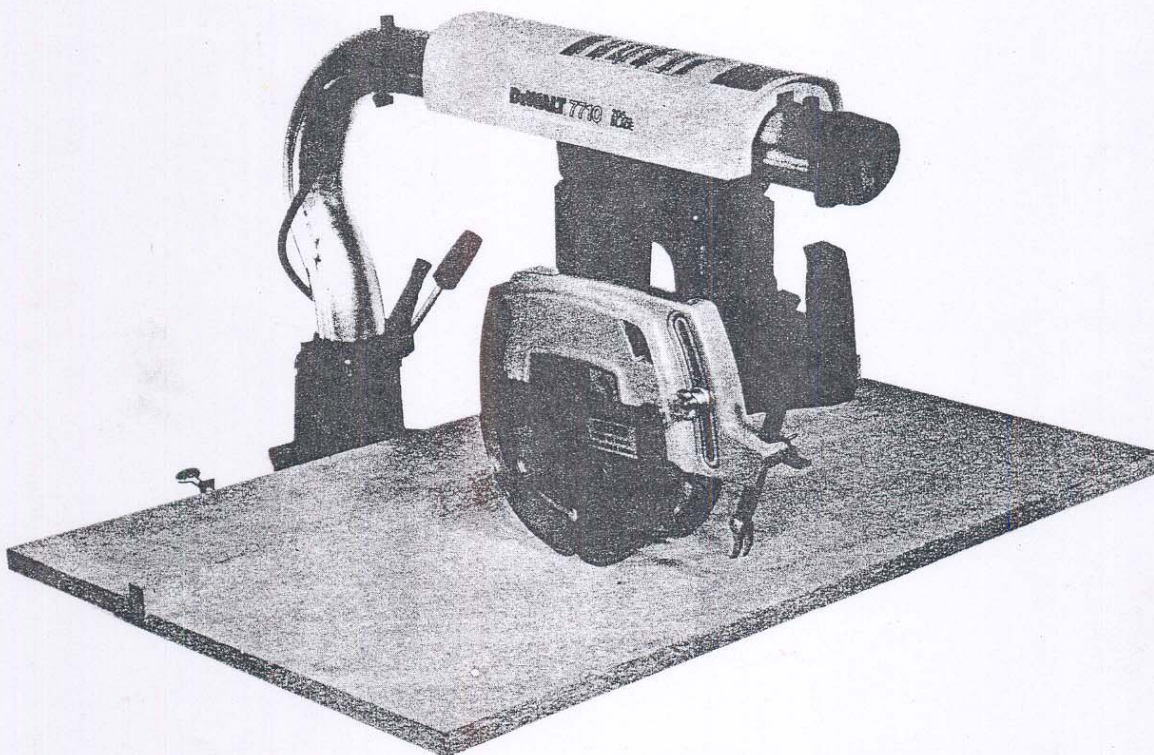

DEWALT®

instruction & maintenance manual



WARNING: FOR YOUR OWN SAFETY, READ THIS MANUAL BEFORE OPERATING TOOL.

This booklet is provided for your convenience in the use and care of your new DeWalt Saw. These instructions include operation, usage, precautions, preventive maintenance, maintenance and other pertinent data to assist you in assuring long life and dependable service from your saw.

710 8" RADIAL ARM SAW

No. 7710/3410, 120 VOLT, TYPE 1

No. 7710-01, 220 VOLT, TYPE 1

No. 7710-02, 240 VOLT, TYPE 1

Bulletin No. 8934

INDEX

Unpacking, Set-Up.	2-3	Precutting Work Surface.	13-15
Machine Controls	4	Basic Cuts	16-20
Introduction	5	Saw Blades & Accessories	21
Rules for Operation and Maintenance	6-7	Fancy Cuts.	22-23
Alignments.	8-11	Parts Lists, Order Instructions.	24-27
Alignment Guide.	12	B&D Service Centers	28

UNPACKING & SET-UP INSTRUCTIONS

You can easily set up your new DeWALT Radial Arm Saw, one of America's most popular power tools. Handling is minimized because every machine is partially assembled for shipment to you. The only tools required are the wrenches furnished with the machine, Phillips screwdriver, regular screwdriver, adjustable wrench, a good square, and a small amount of grease or petroleum jelly. Just follow this easy step-by-step procedure on pages 2 & 3 in setting up your new saw.

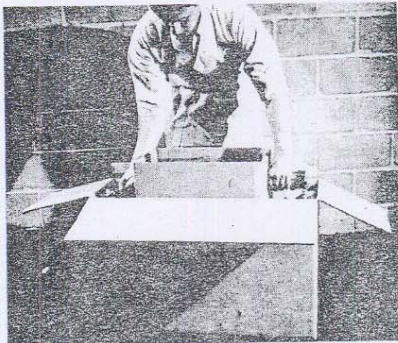

1. Remove arm and motor assembly from carton.

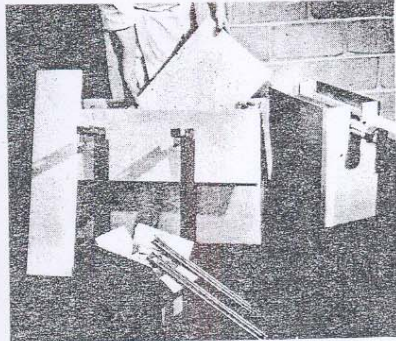

2. Remove remainder of components from carton.

Note: When hardware bags are referred to by color, it refers to the color of the instruction sheet contained inside. Remove hardware bags from base box. Do not open hardware bags until instructed to do so in manual. When opening hardware bags check contents against picture and quantity. Remove the 1/2" wrench from the 'pink' hardware bag. Pick out the 'yellow' hardware bag and put other bags aside. Use yellow sheet to aid in the assembly of the saw.

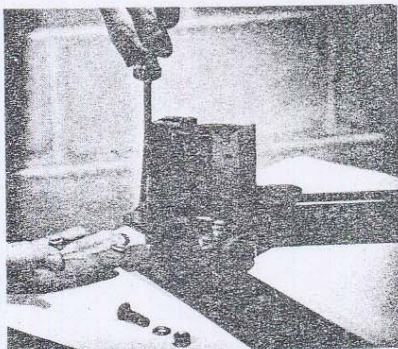

4. Assemble table frame (2 large channel pieces) to the base using (4) flat head 3/8" dia. screws, lock washers and 3/8" dia. nuts. Tighten securely with wrench. See page 26.

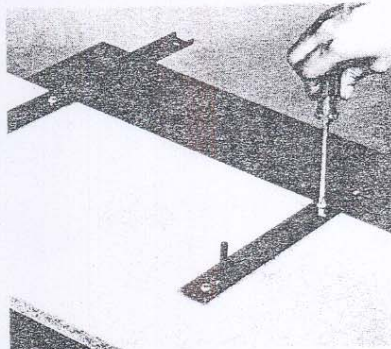

5. Attach the cleats to the underside of the table with the self-tapping screws. Note: Holes are already drilled for you. Tighten securely but do not strip the table top.

3.

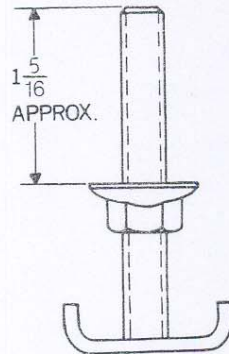

6. Screw (4) large flange hex nuts onto the threaded studs of the table cleats so the studs extend beyond the nuts approximately 1-5/16".

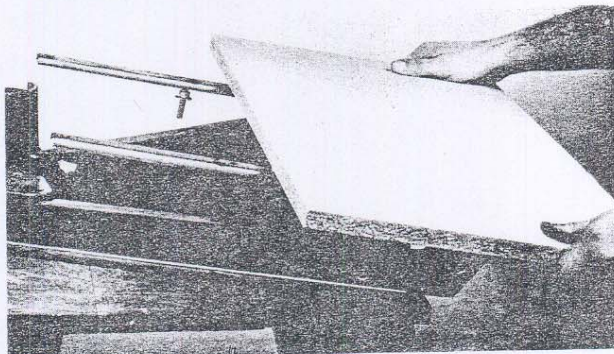

7. Install the table to the frame by putting cleat studs thru the elongated holes in the frame.

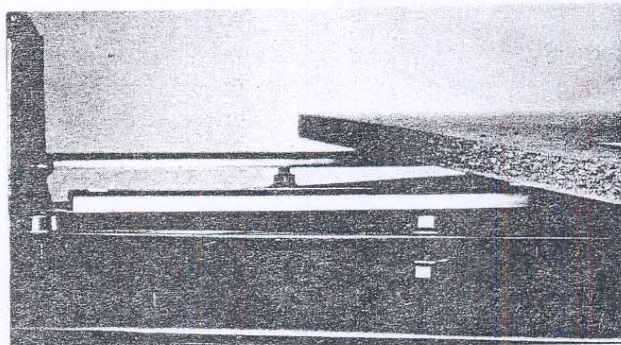

8. Screw (4) large flange hex nuts to the cleat studs and leave loose. These will be tightened when you adjust the table 90° to the arm.

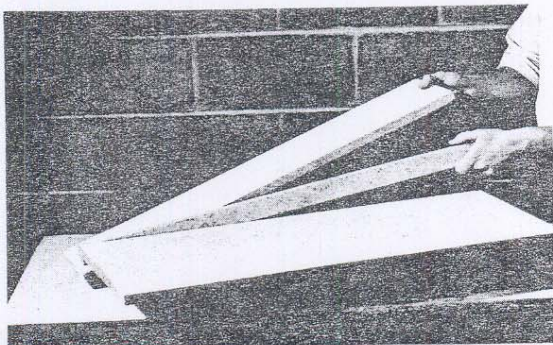

9. Place the fence and back board in position.

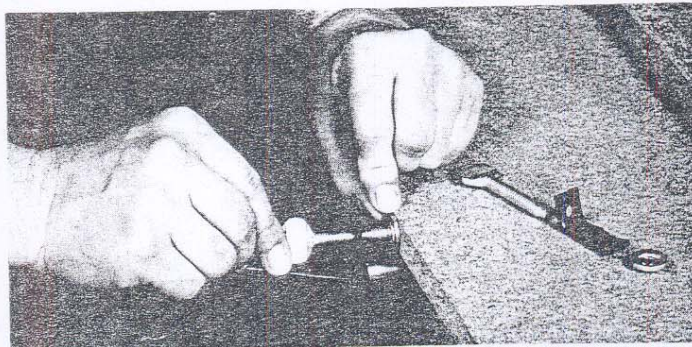

10. Screw the long thumb screw into the cleat bracket and install bracket by slipping it through the rectangular hole in the cleat. With one hand hold the eyelet against the back board in line with the thumb screw while turning the thumb screw with the other hand to force the stud into the eyelet until it snaps in place. Repeat for the other side.

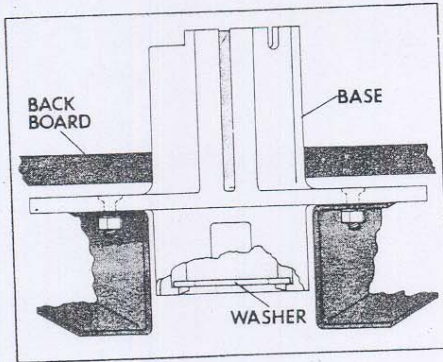

11. Hold the large base washer (in 'orange' bag) at an angle and insert it into the base from the bottom as shown.

IMPORTANT—the bottom of the arm should rest on this thrust washer—see step 14.

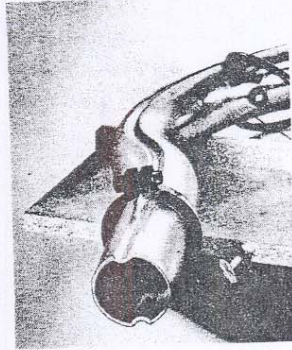

12. Remove the arm and motor assembly from the packing.

13. Remove contents from 'light blue' hardware bag. (Refer to diagram on "Blue" instruction sheet.) Place cap on locking arm and insert 1/2-20 set screws into each side of collar to hold locking arm. Add grease to cavities in locking arm before assembly. Place set screw slugs in 1/4-20 tapped holes in collar and add 1/4-20 set screws. Use hex wrenches from 'pink' hardware bag to aid assembly. The 1/2-20 screws should be tightened so the miter locking arm is tight in position using the (2) 1/4-20 locking screws on top of unit. Form miter scale around collar and attach with (2) #6-32 self-tap screws.

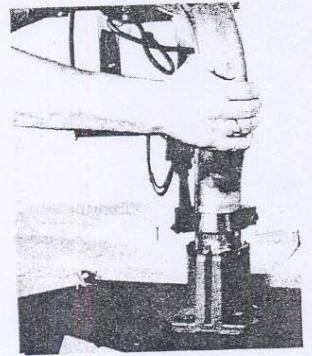

14. Lubricate about 5" of Arm under miter index unit by applying grease over entire surface. Insert the rear of the arm into the base as shown. Turn and wiggle the end of the Arm to ease it into place.

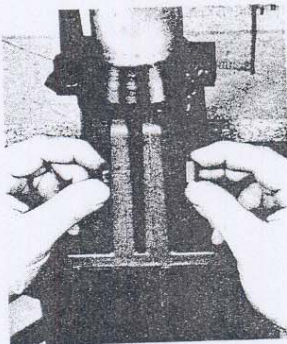

15. Insert 5/16" x 1-3/4" long hex bolt into bottom hole in Base, holding its square nut in the recess. Tighten bolt with a wrench until base is snug around the Arm and no appreciable play is noted.

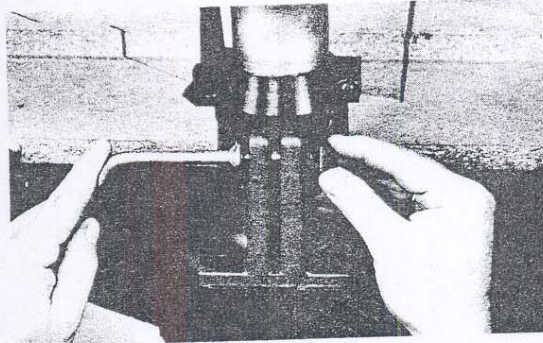

16. Remove base clamp handle from 'pink' hardware bag and 3/8" I.D. flat washer from 'orange' hardware bag, (lubricate washer and threads with small amount of grease), place base clamp handle into top hole of base with the square nut in the recess. (1.) Position base clamp so that when it is locked the handle position will be upright. If it is not, loosen the clamp rod sufficiently to permit nut to come out of recess in casting, then turn the nut 1/4 or 1/2 turn while holding clamp rod. Retighten base clamp. (2.) Place insert into plastic knob. Push knob on clamp handle. ('orange' bag.) (3.) Release the base clamp by pulling it toward you. You should now be able to push the arm to the right and left and feel a slight drag. If it is too hard to move, loosen the 5/16" bolt a little.

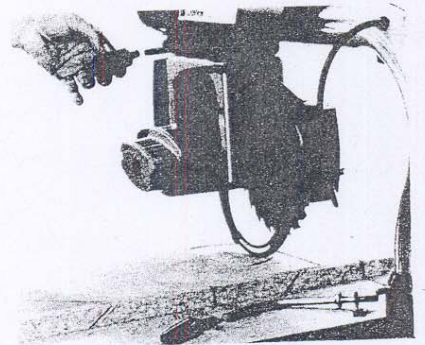

17. Place insert into plastic knob. Push knob onto clamp handle.

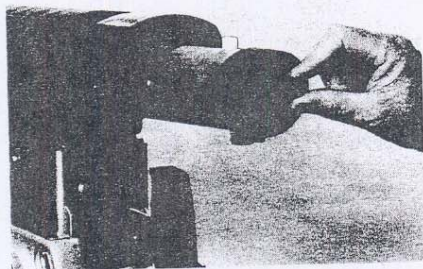

18. Do not plug saw into receptacle at this time. Insert key ('pink' hardware bag) in slot with notch down. Switch can now be operated. Turn switch off and remove key with upward and outward motion.

19. MOUNT YOUR SAW ON A LEG STAND, STURDY WORK BENCH, OR APPROPRIATE TABLE. TABLE TOP OF SAW SHOULD PROTRUDE APPROXIMATELY FOUR (4) INCHES OVER MOUNTING SURFACE. THIS UNIT WILL FIT A 35021 DELUXE MACHINE STAND. USE STURDY OUTRIGGER SUPPORTS IF ANY TABLE EXTENSIONS ARE ATTACHED TO THE SAW.

INSTALLING BLADE

To install the blade rotate the saw to the out-rip position (see page 6) at the end of the arm as shown. Make sure saw is all the way to the out-rip position (against front bumper) and in its highest elevated position (see page 6). If saw is not against front bumper, it is slightly out of phase with cover and arm. To correct, follow instructions at bottom of page 12. Now raise the lower guard with the lift tab provided and secure guard in raised position by placing your fingers under the guard just above the arbor (see above illustration). Blade can now be installed or removed without touching table top. Place blade on arbor following the illustration on the guard so the teeth of the blade and direction arrow point in the proper direction. When tightening or loosening blade arbor screw, the blade can be held secure by inserting a screwdriver through the hole in the blade, and allowing screwdriver to rest against the upper guard. A piece of scrap lumber held against the blade teeth and resting on the upper guard will serve the same purpose. Do not try to hold the blade with your hand!

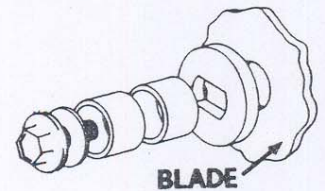

Place the large arbor washer on the outside of the blade, then (2) spacer washers and arbor screw. Note: left hand thread. CAUTION: Never assemble spacer washers or arbor screw directly against blade.

IMPORTANT CLUTCH ADJUSTMENT:

Tighten arbor screw until the spring washer flattens. Then back off 1/6 turn (one flat on the hex head). This allows blade to slip on spindle if it should jam in the work. If blade jams stop saw immediately! Clutch will not function if the screw is not set properly.

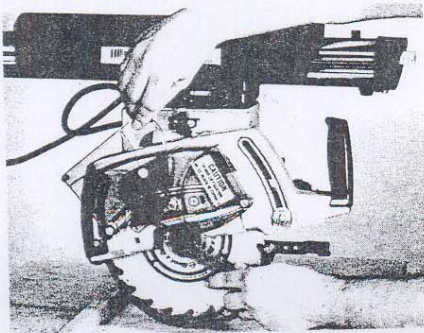

RADIAL-ARM MACHINE CONTROLS. The versatility of the radial-arm machine is due, in part, to its controls, and these are the keys to its successful operation. Learn to use them by adjusting the machine for all operations before actually starting to operate it. All controls, as well as the major parts of the radial-arm machine, are shown and identified here.

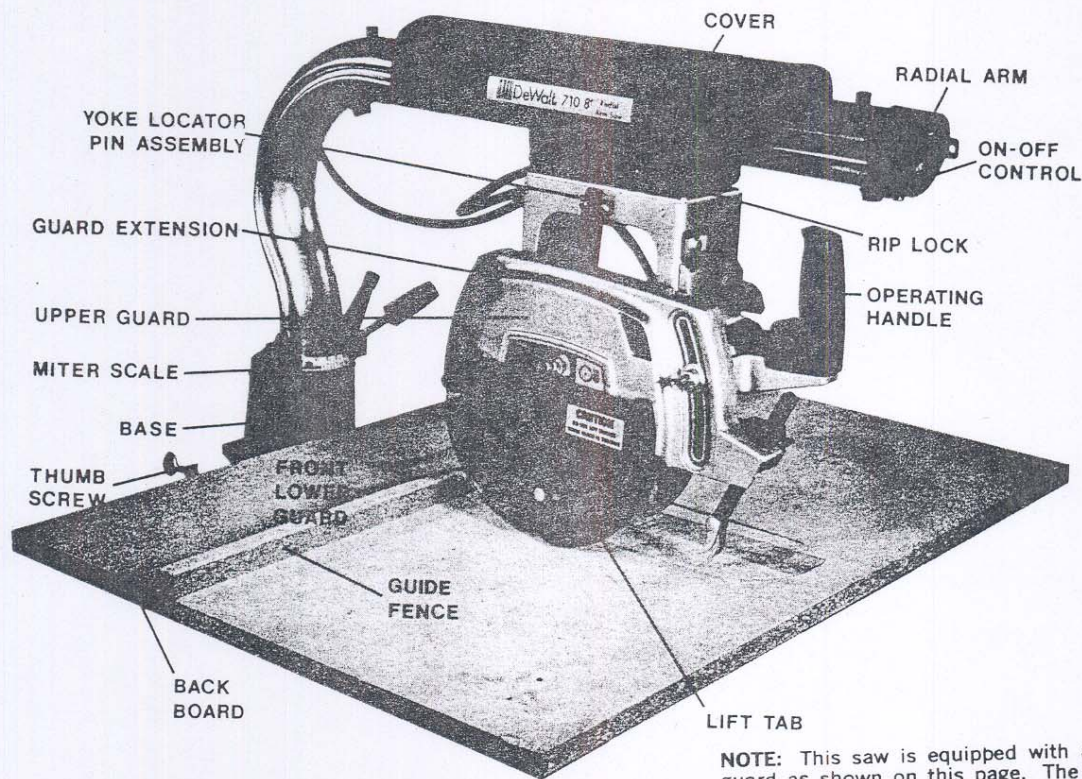

NOTE: This saw is equipped with a new lower blade guard as shown on this page. The guard is there for your protection and should not be removed for any reason. It rises over the workpiece automatically and needs manual manipulation only as described later on in this manual. It is required for OSHA Regulation work plans.

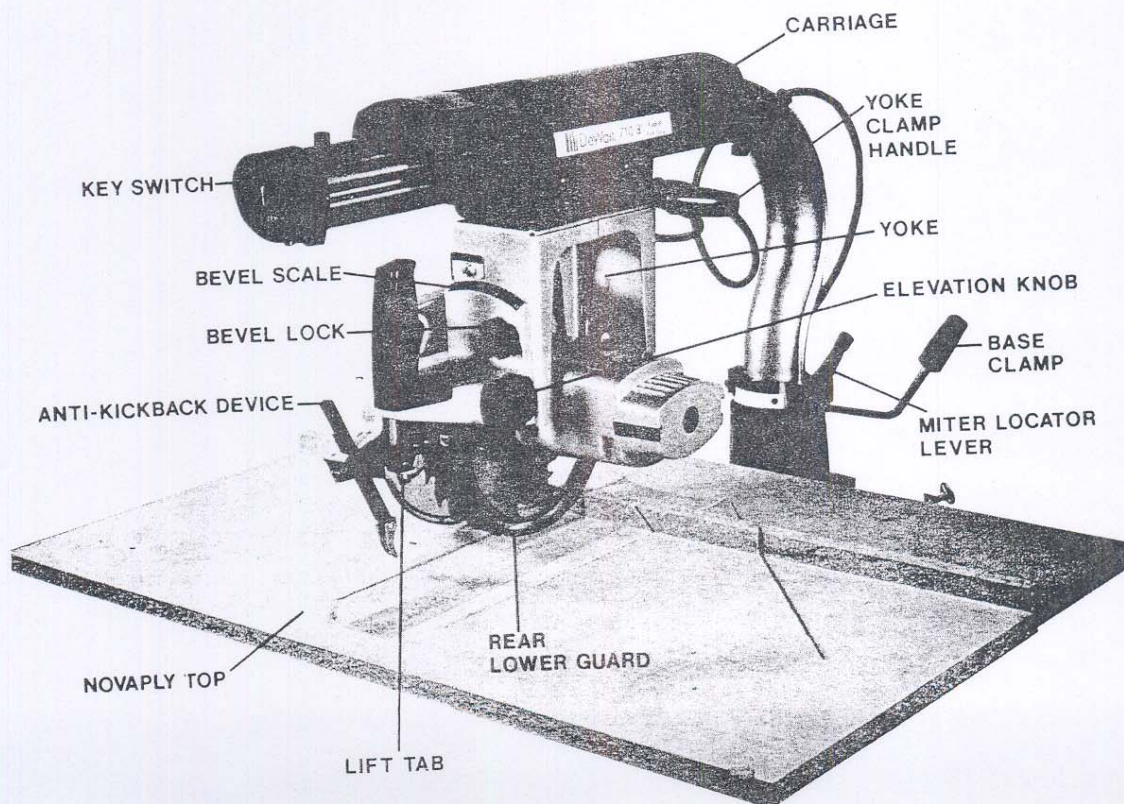

INTRODUCTION

You have now set up your saw by following the preceding directions. But **before plugging in the saw**, there are **three important things** you must do.

1. Familiarize yourself thoroughly with the principles of radial arm sawing. See Page 5 for names of components.
2. Familiarize yourself thoroughly with the rules and instructions for operation on next two pages.
3. Carefully follow the alignment and adjustment procedures.

The five basic movements are shown below. See pages 16 to 20 for more details.

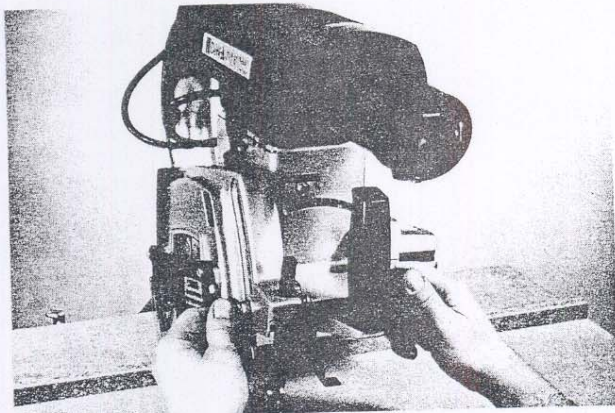

ELEVATION—Release wing nut with left hand and turn black knob with right hand. This raises and lowers saw. Lock in position by tightening wing nut.

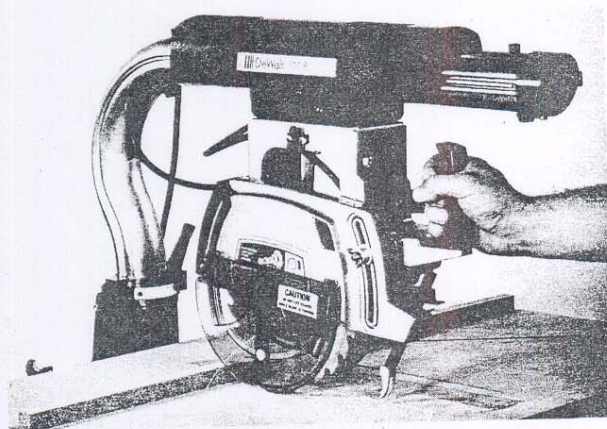

CROSS CUTTING—Elevate saw until it clears fence. Unlock riplock by turning counterclockwise — pull saw back and forth. (If at anytime the saw does not go all the way behind the fence or it does not hit the front bumper refer to rollerhead adjustment on page 12).

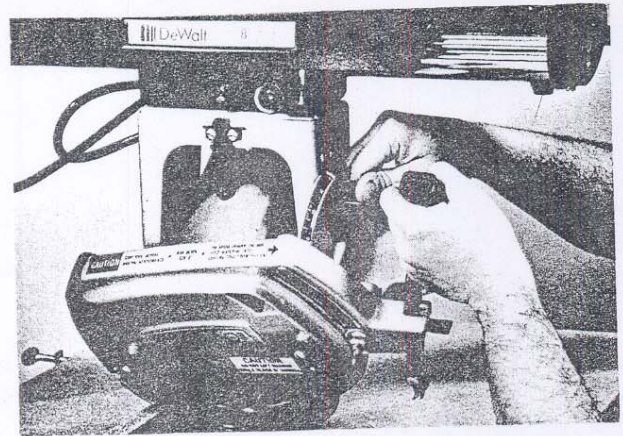

BEVELING—Elevate saw all the way up. Release the bevel lock knob—rotate saw to desired angle. (Saw automatically stops at 45°). Relock Knob.

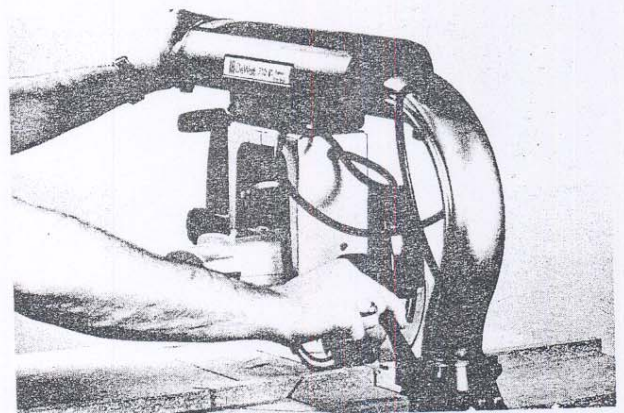

MITERING—Reach around to base and release clamp handle. Release miter locking arm and rotate saw to desired angle. Fixed locating slots are located at 0° and left and right 45°. Push down on miter locking arm and lock base clamp. Any other angle between these points is available by leaving miter locking arm up, locating desired angle, and tighten base clamp handle.

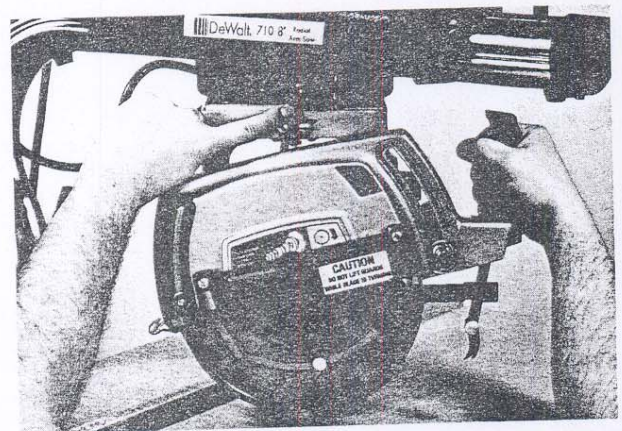

RIPPING—Release yoke clamp handle by pulling it toward you. Rotate motor slightly clockwise (looking down), and using left index finger depress index pin handle and rotate saw to in-rip or out-rip position. (See page 19). When pin clicks into place, lock yoke clamp handle.

RULES FOR SAFER OPERATION OF STATIONARY POWER TOOLS

1. **KEEP GUARDS IN PLACE** and in working order.
2. **REMOVE ADJUSTING KEYS AND WRENCHES.** Form habit of checking to see that keys and adjusting wrenches are removed from tool before turning it on.
3. **KEEP WORK AREA CLEAN.** Cluttered areas and benches invite accidents.
4. **DON'T USE IN DANGEROUS ENVIRONMENT.** Don't use power tools in damp or wet locations, or expose them to rain. Keep work area well lighted.
5. **KEEP CHILDREN AWAY.** All visitors should be kept a safe distance from work area.
6. **MAKE WORKSHOP KID PROOF** with padlocks, master switches, or by removing starter keys.
7. **DON'T FORCE TOOL.** It will do the job better and be safer at the rate for which it was designed.
8. **USE RIGHT TOOL.** Don't force tool or attachment to do a job for which it was not designed.
9. **WEAR PROPER APPAREL.** No loose clothing, gloves, neckties, rings, bracelets, or other jewelry to get caught in moving parts. Nonslip footwear is recommended. Wear protective hair covering to contain long hair.
10. **ALWAYS USE SAFETY GLASSES.** Also use face or dust mask if cutting operation is dusty. Everyday eyeglasses only have impact resistant lenses, they are NOT safety glasses.
11. **SECURE WORK.** Use clamps or vise to hold work when practical. It's safer than using your hand and it frees both hands to operate tool.
12. **DON'T OVERREACH.** Keep proper footing and balance at all times.
13. **MAINTAIN TOOLS WITH CARE.** Keep tools sharp and clean for best and safest performance. Follow instructions for lubricating and changing accessories.
14. **DISCONNECT TOOLS** before servicing; when changing accessories such as blades, bits, cutters, etc.
15. **REDUCE THE RISK OF UNINTENTIONAL STARTING.** Make sure switch is in off position before plugging in.
16. **USE RECOMMENDED ACCESSORIES.** Consult the owner's manual for recommended accessories. The use of improper accessories may cause risk of injury to persons.
17. **NEVER STAND ON TOOL.** Serious injury could occur if the tool is tipped or if the cutting tool is unintentionally contacted.
18. **CHECK DAMAGED PARTS.** Before further use of the tool, a guard or other part that is damaged should be carefully checked to determine that it will operate properly and perform its intended function—check for alignment of moving parts, binding of moving parts, breakage of parts, mounting, and any other conditions that may affect its operation. A guard or other part that is damaged should be properly repaired or replaced.
19. **DIRECTION OF FEED.** Feed work into a blade or cutter against the direction of rotation of the blade or cutter only.
20. **NEVER LEAVE TOOL RUNNING UNATTENDED. TURN POWER OFF.** Don't leave tool until it comes to a complete stop.

MAINTENANCE & OPERATION

1. Be sure blade rotates clockwise when facing arbor.
2. Secure table frame to a bench table, leg stand, etc. before operating saw. It is recommended that whatever saw support is used should slope to the rear sufficiently to prevent the blade unit from creeping forward due to gravity and it should be securely anchored to the floor to prevent undesired movement.
3. Be sure all clamp handles are tight before starting any operation. Push back to tighten. Pull to loosen.
4. Make sure blade and arbor collar are clean and collar is against blade. Tighten arbor screw securely, and set clutch. (See clutch instructions).
5. Keep the saw blade sharp and properly set.
6. **Use anti-kickback device on guard; never remove it.** (See Ripping Instructions.)
7. Keep arm tracks and bearing surfaces clean and dry. Periodically lubricate balls and tracks with a dry lubricant.
8. Periodically recheck alignment (see alignment chart).
9. Keep motor air slots clean and free of chips.
10. Do not attempt to operate saw on anything but the designated voltage.
11. Do not use blades of larger diameter than 8".
12. **Keep the saw blade sharp.** Cracked or improper type blades should not be used.
13. Never oil or grease arm tracks or the motor.
14. Do not wedge anything against fan to hold motor shaft.
15. Saw and table top should be kept away from dampness.
16. **Never force cutting action.** Stalling or partial stalling of the motor is dangerous and can cause major damage to motor winding. **If motor stalls turn switch off immediately.**
17. **Do not remove ground prong from plug. Never operate the saw unless it is properly grounded.**
18. Be sure you are alert. If you are fatigued, rest before you work.
19. **Always use blade guard properly adjusted for the operation you are performing. CAUTION: Do not clean the lower plastic guard with solvents or soaps. Use ONLY a cloth dampened with water.**
20. The motor and yoke should be safely behind the guide fence before you start to cut. The saw should always be returned to the rear of the table after making a cut, and before you remove any stock from the table.
21. **Be certain the equipment is turned off before making any adjustments.**
22. When ripping, **always feed the material past the blade guard from the side opposite the anti-kickback device. Never stand in back, or in direct line with the saw blade. Never rip from the wrong end.**
23. The saw blade or tool should be completely stopped, and switch key removed, before you leave the machine.
24. Always turn switch off before removing key.

INSTRUCTIONS

ELECTRICAL CONNECTIONS AND GROUNDING

This tool should be grounded while in use to protect the operator from electric shock.

We recommend that you **NEVER** disassemble the tool or try to do any rewiring in the electrical system. Any such repairs should be performed only by B&D Service Centers or other qualified service organizations. Should you be determined to make a repair yourself, remember that the green colored wire is the "grounding" wire. Never connect this green wire to a "live" terminal.

1. **Cord-Connected Tools:** In the event of a malfunction or breakdown, grounding provides a path of least resistance for electric current to reduce the risk of electric shock. This tool is equipped with an electric cord having an equipment-grounding conductor and a grounding plug. The plug must be plugged into a matching outlet that is properly installed and grounded in accordance with all local codes and ordinances. Do not modify the plug provided — if it will not fit the outlet, have the proper outlet installed by a qualified electrician. Improper connection of the equipment-grounding conductor can result in a risk of electric shock. The conductor with insulation having an outer surface that is green with or without yellow stripes is the equipment-grounding conductor. If repair or replacement of the electric cord or plug is necessary, do not connect the equipment-grounding conductor to a live terminal. Check with a qualified electrician or serviceman if the grounding instructions are not completely understood, or if in doubt as to whether the tool is properly grounded. Use only 3-wire extension cords that have 3-prong grounding plugs and 3-pole receptacles that accept the tool's plug. Repair or replace damaged or worn cord immediately.

1A. Grounded, cord-connected tools intended for use on a supply circuit having a nominal rating less than 150 volts. This tool is intended for use on a circuit that has an outlet that looks like the one illustrated in Sketch A. The tool has a grounding plug that looks like the plug illustrated in Sketch A. A temporary adapter, which looks like the adapter illustrated in Sketches B and C, may be used to connect this plug to a 2-pole receptacle as shown in Sketch B if a properly grounded outlet is not available. The temporary adapter should be used only until a properly grounded outlet can be installed by a qualified electrician. The green-colored rigid ear, lug, etc. extending from the adapter must be connected to a permanent ground such as a properly grounded outlet box. Adapter shown in Sketches B and C is Not for Use in Canada.

1B. Grounded, cord-connected tools intended for use on a supply circuit having a nominal rating between 150-250 volts, inclusive: This tool is intended for use on a circuit that has an outlet that looks like the one illustrated in Sketch D. The tool has a grounding plug that looks like the plug illustrated in Sketch D. Make sure the tool is connected to an outlet having the same configuration as the plug. No adapter is available or should be used with this tool. If the tool must be reconnected for use on a different type of electric circuit, the reconnection should be made by qualified service personnel; and after reconnection, the tool should comply with all local codes and ordinances.

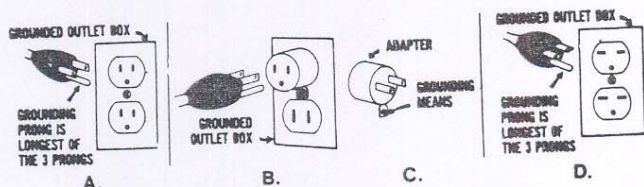

EXTENSION CORD

When using the tool at a considerable distance from power source, a 3-conductor, grounding-type extension cord of adequate size must be used for safety and to prevent loss of power and over-heating. Use the following table to determine the minimum wire size required.

Use only 3-wire extension cords which have 3-prong type plugs and 3-pole receptacles which accept the tool's plug. Replace or repair damaged or worn cord immediately.

Ampere rating (on nameplate)	0 to 2.0	2.10 to 3.4	3.5 to 5.0	5.10 to 7.0	7.10 to 12.0	12.1 to 16.0
Ext. Cable length	Wire Size (A.W.G.)					
25 ft.	18	18	18	18	16	14
50 ft.	18	18	18	16	14	12
75 ft.	18	18	16	14	12	10
100 ft.	18	16	14	12	10	—
150 ft.	16	14	12	12	—	—
200 ft.	16	14	12	10	—	—

MOTOR

Your DeWALT tool is powered by a B&D-built motor. Be sure your power supply agrees with nameplate marking. **Volts 50/60 Hz** means **Alternating Current ONLY**. Voltage variation of more than 10% will cause loss of power and over-heating. All DeWALT tools are factory-tested; if this tool does not operate, check the power supply.

The use of a separate circuit independent of the lighting circuit is recommended.

MOTOR BRUSHES

It is recommended that the carbon brushes and the brush springs be replaced when motor arcing becomes excessive.

If the surface of the commutator is pitted or grooved, we recommend the unit be taken to a DeWalt or Black & Decker Service Center for repair. Otherwise, brushes and springs may be replaced as follows:

1. Unplug saw from power supply.
2. Slide brush holder cover toward rear of motor housing (hold hand in front of opening to prevent spring from flying from opening). See photo below.
3. Remove spring along with terminal and lead wire.
4. Use a piece of stiff wire, such as an opened paper clip, to reach inside the brush holders and pull brushes out.
5. Insert new carbon brushes into the holder with the radius toward the commutator.
6. Thread new springs into the terminals and spring caps. Insert into brush holders and replace brush holder covers.
7. Plug saw into power supply and allow saw to run idle for 15 minutes to seat the brushes.

For any other motor maintenance we recommend you take the unit to a DeWalt or Black & Decker Service Center.

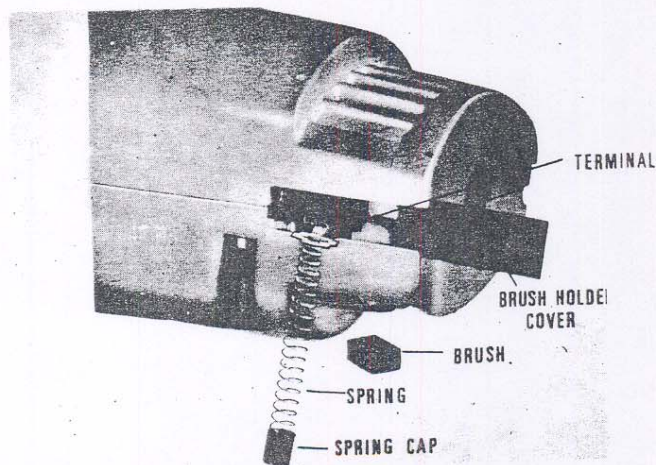

ALIGNMENT

MAKE CERTAIN SAW IS NOT CONNECTED TO POWER SOURCE. NOW BEFORE GOING ANY FARTHER TAKE TIME OUT TO READ THE FOLLOWING IMPORTANT INSTRUCTIONS. THE ALIGNMENT OF YOUR NEW SAW IS MOST IMPORTANT FOR MAKING ACCURATE CUTS. THE TIME SPENT HERE WILL ADD CONSIDERABLY TO YOUR OVERALL ENJOYMENT OF THIS FINE PRODUCT.

NOTE: SECURE TABLE FRAME OF UNIT TO A STURDY WORK BENCH, APPROPRIATE TABLE, OR LEG STAND, WITH SCREWS OR BOLTS BEFORE MAKING ALIGNMENTS OR OPERATING.

ADJUSTING TABLE TOP PARALLEL WITH ARM

NOTE: The upper saw guard should be approx. parallel with the table when the blade is touching the table. If it is not, adjust the table by turning the nuts on the table adjusting screws.

You will notice the mounting bolts, which hold the table to the frame, are quite long. The large flange nuts, on the top and bottom of the frame, suspend the table above the frame about 1". There is an important reason for this construction. By turning these nuts up or down we can adjust the table parallel to the arm. If the table is parallel to the arm, then any groove you cut will be the same depth from front to back. A simple method of adjusting the table to be parallel with the arm is as follows:

1. With arm in cross cut position tighten base clamp handle. Turn the anti-kickback rod on the guard upside-down. The lower end of the rod will be used as an indicator to determine if the entire table surface is the same distance from the arm.
2. Set the elevation adjustment so the end of the rod is about 1/8" above the table top. Tighten elevating wing nut. (Fig. A-1).
3. Push the saw all the way back. If the rod strikes the surface, as you push it back, elevate it a little more so it is 1/8" above as before.
4. Pull saw forward. Release base clamp handle, release miter locating lever and move the arm to your right until 30° is indicated on the miter scale. As you move the arm, if the end of the rod strikes the table, elevate it a little more as before. With the arm 30° to the right, base clamp handle tightened and the saw all the way back, turn the height adjustment until the rod is just above the surface of the table and lock elevating wing nut.
5. Hand tighten the nuts on the back right table suspension stud while still in 30° right position.
6. Pull the saw forward to the end of the track. If the end of the rod strikes the table **do not** change the height adjustment of the saw. Instead, lower the front right side of the table by turning the upper nut on the suspension stud up a few turns. You should now be able to push the front right corner of the table down so the rod indicator can pass over the surface without striking it.
7. Adjust the suspension stud nuts so the top of the table on the front right side just touches the end of the anti-kickback rod the same as the back. Tighten the nuts by hand.
8. Release base clamp handle and swing the arm to the left until 30° is indicated on the miter scale. Tighten base clamp handle and check the height. If it is incorrect, adjust the same as before. Do not change motor height. Push the saw back and adjust the rear left side of the table. Hand tighten adjusting nuts.
9. Replace kickback to its proper position.

Incidentally, you do not have to start the table adjustment with the right rear bolt. You can start with any one of the bolts, if you find it more convenient. **When checking any adjustments arm must always be locked in base.**

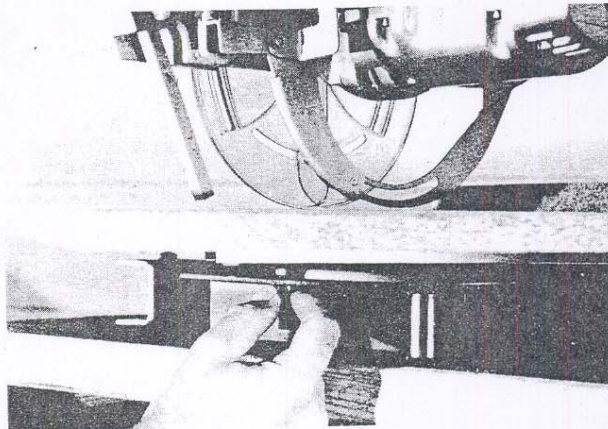

Fig. A1

ADJUSTING FOR SQUARE CROSS CUT

Install blade (See Page 4 for installation instructions). Now you are ready to adjust the arm to be 90° to the fence. You will notice the saw locates at 90° when the miter locking arm is located in the center slot of the locating ring. The taper helps to locate the same position each time. Always tighten the base clamp and you will have accurate cuts. As of now this does not mean the arm is 90° to the fence. Check it as follows:

1. Put the fence in its normal position, with the blade in front of it and about 1/32" above the table.
2. Place a carpenter's square against the fence on the left side of the blade and against the blade itself, not the guard. Raise the lower guard out of the way.
3. Hold the square with your left hand and pull the saw forward (Fig. A2 on next page). If the arm is 90° the blade will stay against the square as you pull it out. If the arm is too far to the right, the blade will move away from the square. If it is too far to the left, it will push the square to the left. In either case correction is easy.
4. Since the nuts which hold the table to the frame are not tight, you can shift the entire table in relation to the arm by tapping the table corners with your hand or lightly with a hammer (Fig. A3 on next page).
5. When table is located so the fence is 90° to the arm, tighten the adjusting nuts on the suspension studs carefully so as not to change the adjustment you just made.
 - a.) Tighten the bottom nuts only. This will draw the table down only slightly but the same amount on each stud.
 - b.) Prevent shifting by taking up on the first nut a little and then proceed to the next taking it up a little also.
 - c.) After all (4) nuts are snug, take up on the first again a little more and repeat on all the other nuts.
 - d.) The third time around you should be able to take them up tight without any shifting.

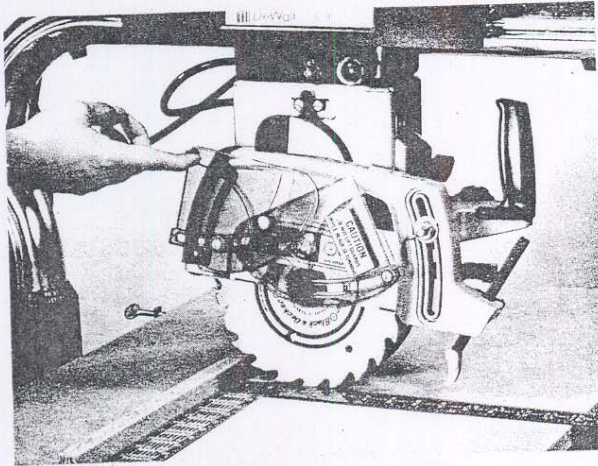

Fig. A2

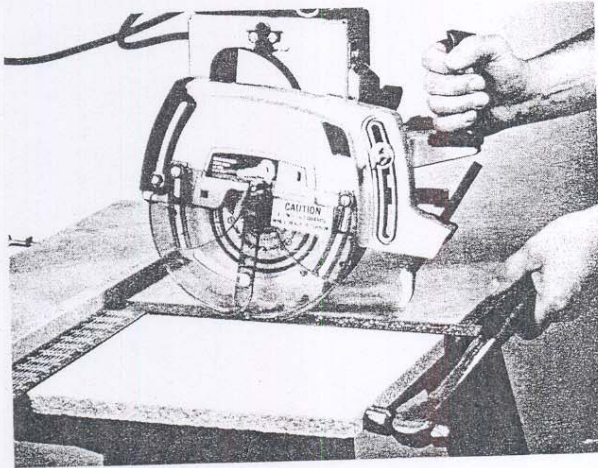

Fig. A3

MAKING MITER ADJUSTMENT

When the arm is 90° to the table, set the miter scale by loosening the two mounting screws and move the scale so that the 0° mark lines up with the white line on the locating ring. Tighten mounting screws (Fig. A4). Once the saw has been set for 90°, it should be set automatically for 45°, right and left.

Over a period of time the miter locking arm will wear and become loose on its mounting screws. These will have to be kept snug as any looseness will affect accuracy. These screws can be used to fine set for square cross cut. Loosen (2) 1/4-20 locking screws and loosen 1/2-20 screw in direction opposite direction arm is to move. Tighten opposite screw and lock screws in position. Check for squareness and repeat as necessary. Check for square cross cut any time there is adjustment in the screws (Fig. A5).

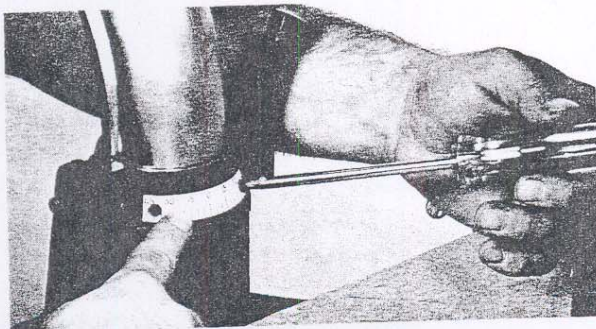

Fig. A4

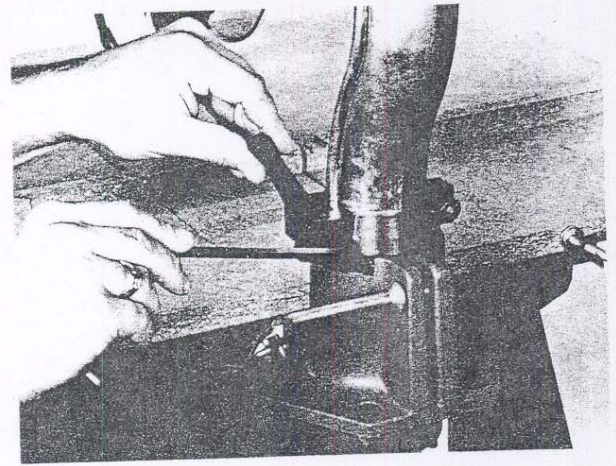

Fig. A5

ADJUSTING SAW BLADE PERPENDICULAR TO TABLE TOP

Align the blade to be 90° to the table as follows:

1. Loosen the bevel lock knob and locate the saw to the 0° position as far as it will go.
2. Look in the back of the bevel knob (the inside of the front of the yoke) and you will see a steel plate with (2) curved slots. The bolt to the bevel lock knob passes through the upper slot. A cast protrusion (called a boss) rides in the lower slot. This boss, moving to the ends of the slot, precisely locates the blade at 90° or 45° to the table. See Fig. A6.
3. Raise the lower guard and place your combination square on the table against a flat portion of the blade Fig. A8. If the blade is not 90°, loosen the screw that holds the bevel pointer and also loosen the bevel lock knob. Shift the saw until the blade is 90°.
4. The boss should be against the end of the slot of the steel locator plate. If it is not, move the plate by hand until it is.
5. Lock the bevel knob.
6. Set bevel pointer to read 0° and tighten its screw.

View As Seen From
Inside Yoke

BOSS

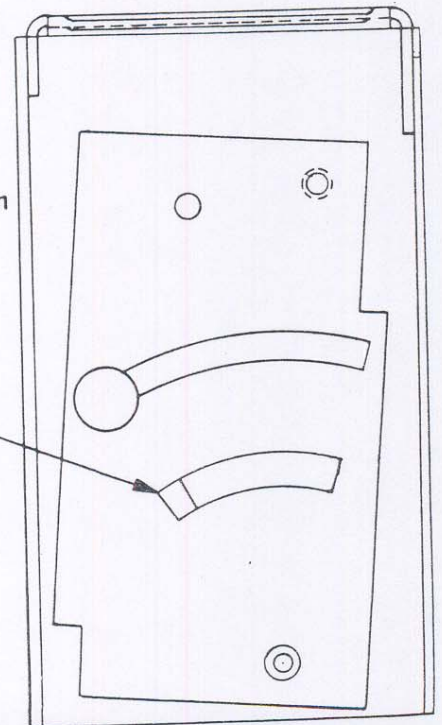

Fig. A6

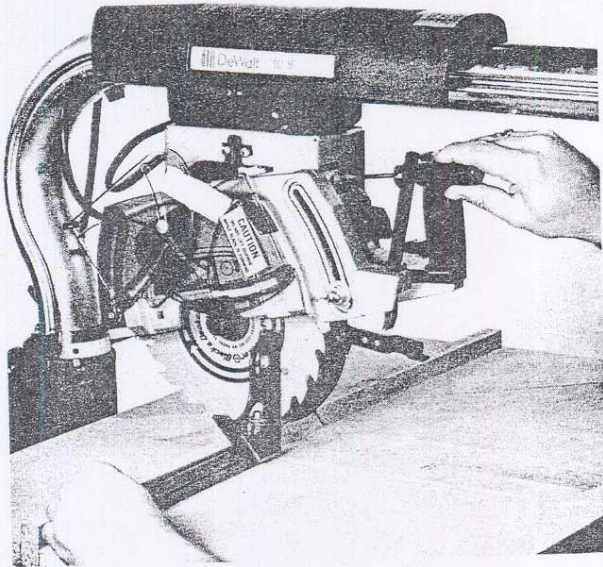

Fig. A8

ADJUSTING CROSS-CUT TRAVEL PARALLEL TO ARM TRACKS (HEEL ADJUSTMENT)

This is the last immediate adjustment and it is to make certain the blade is parallel to the arm tracks and also that it is parallel to the fence when you are ripping. Adjust as follows:

1. Move saw to front of fence and lock elevating wing nut.
2. Loosen the (2) screws which hold the locator pin assembly several turns (Fig. A9).
3. Loosen the yoke clamp handle.
4. Set the blade perpendicular to the fence (with the lower guard raised) by using a combination square as shown in Fig. A10.
5. Lock the yoke clamp handle.
6. Tighten the screws securely.

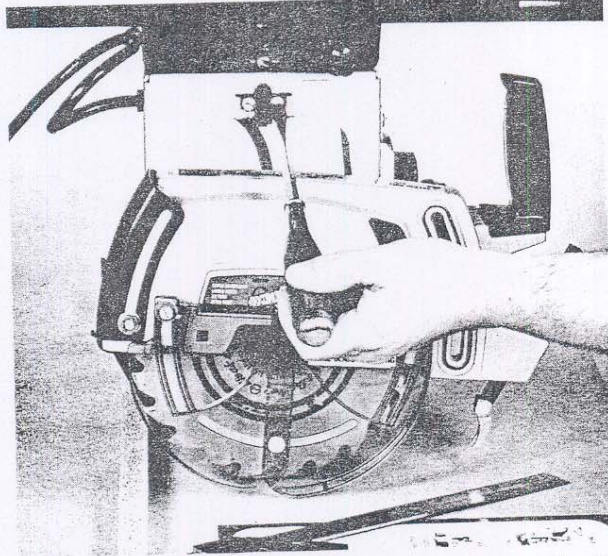

Fig. A9

The blade is now in correct adjustment. **Keep in mind the arm must be 90° to the fence before you make this adjustment, otherwise, you will adjust to a false condition.** A simple method of checking this adjustment is to rotate the saw to the in-rip position and check to see if the blade is parallel to the fence. (Fig. A12). (Be sure to raise the guard again before pulling the saw from the fence). If it is not, before readjusting, go back and check the crosscut adjustment. Then readjust.

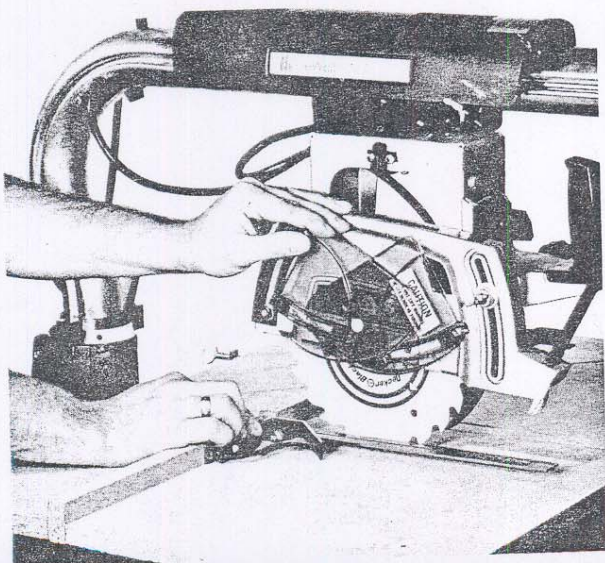

Fig. A10

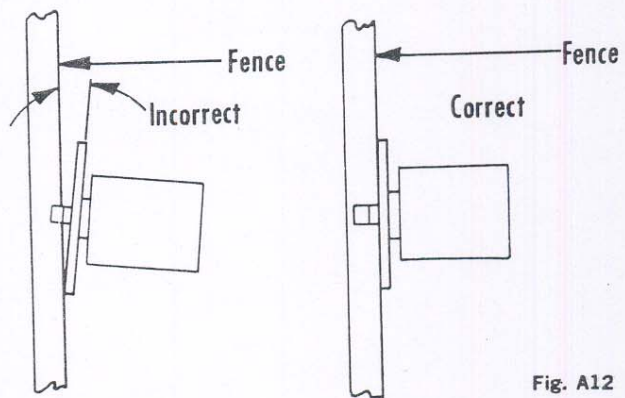

Fig. A12

LONG TERM ADJUSTMENTS

1. ROLLER HEAD ADJUSTMENT

The first, and most important, is the roller assembly on which the saw moves forward and back. This roller head assembly has two grooved plates which straddle the ball bearings. Two set screws on the roller head can push the plates tighter against these bearings. To adjust these set screws, remove two (2) screws in top of cover and lift cover off. If the roller head is not tight enough the ball retainer assembly gets out of phase with the carriage. This will prevent the saw from returning all the way behind the fence or prevent it from making a full crosscut. If this happens, pull the saw toward the front bumper with a hard tug several times until the carriage hits the front bumper.

CAUTION: Tighten both set screws an even amount in order to keep the rollerhead snugly fastened to the arm. If the adjustment is too tight, it will be difficult to pull the saw back and forth. In that case, back off on the screws a little, **but not too much**. The amount of drag should be sufficient so that the roller head does not get out of phase, that is it should strike back bumper when pushed completely back and strike front bumper when pulled completely forward. After making this adjustment check to see if blade is 90° to the table top. Replace cover by lining up holes in cover with holes in the raised sections of the ball retainer assembly. Replace screws and tighten securely (Fig. A13).

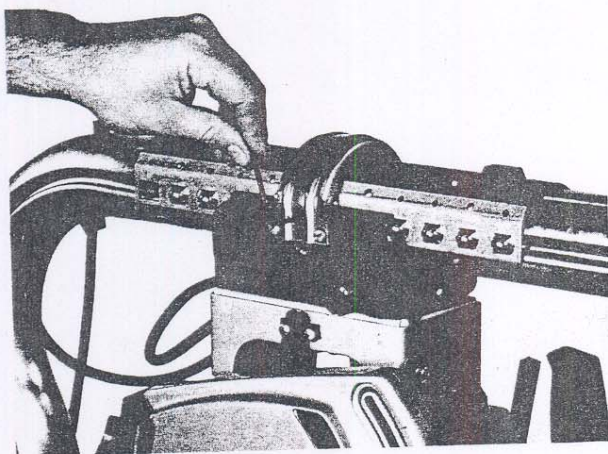

Fig. A13

2. YOKE CLAMP HANDLE

The purpose of this handle is to provide a friction lock between the upper face of the yoke and the bottom face of the rollerhead. It should also eliminate any play between these two parts. To lock, the handle is pushed back from the hand grip of the yoke. If at any time it is possible to move this handle so that it strikes the back part of the carriage it is not in proper adjustment. Its proper position when locked is approximately 90° or less to the hand grip of the yoke.

To adjust (Fig. A14):

1. Loosen the yoke lock lever by pulling it toward you.
2. Back off the screw located directly above the yoke locator pin assembly several turns, this will release lock on the large lockwasher. Using a screwdriver in the large slot on the opposite side of the carriage, turn the large lock washer one, two or three notches. Turn clockwise to tighten, counter clockwise to loosen. (Each notch gives 15° rotation). **DO NOT MAKE IT TIGHT.**
3. Turn screw into a new notch in the large lockwasher and tighten yoke lock lever. To assure that you have the notch located in line with the screw, be sure that a notch is visibly in line with the middle of the yoke. Line up a notch with the center of the yoke. Turn the screw in just far enough to contact the notch in the washer. Do not overtighten.

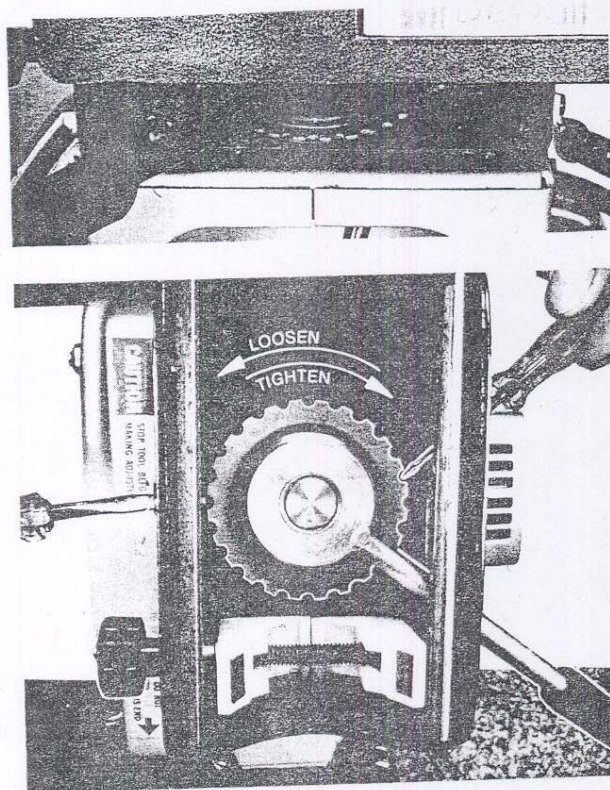

Fig. A14

3. ELEVATION ADJUSTMENT

CAUTION: If motor tends to move down when wing nut is loose adjustment needs tightening.

If the saw is too tight or too loose when elevating, it is out of adjustment.

To Adjust (Fig. A15):

1. Remove wing nut and cupped washer from elevating shaft adjacent to guard.
2. With right hand holding elevating knob, tighten or loosen nut with wrench as shown.
3. After adjustment, saw must elevate easily with minimum motor play. **Motor must not drop when wing nut is loose and must not be easily moveable without turning elevation knob.**
4. When saw elevation is satisfactory, replace cupped washer and tighten wing nut.

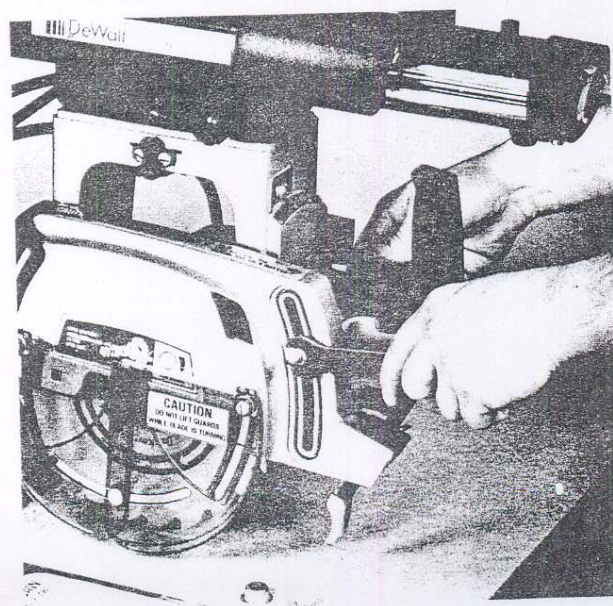

Fig. A15

ALIGNMENT GUIDE FOR ACCURATE CUTTING

It is important to realize that an improperly adjusted saw just will not yield the accurate cuts desired. If the machine seems to cut inaccurately, its adjustments and alignments should be checked.

The following guide is listed for your convenience. However, **changing one adjustment will affect another, so it is best to perform all of the alignment procedures when correcting any one problem.**

PROBLEM	POSSIBLE CAUSE
1. Saw will not make a square cross cut or a good 45° miter cut.	Arm is not perpendicular to guide fence.
	Arm not indexed to the right.
	Too much play between arm and base.
	Roller head too loose on arm.
	Yoke too loose when clamped to roller head.
	Saw dust between lumber and guide fence.
	Table not parallel with arm.
	Guide fence not straight.
2. Lumber has a tendency to walk away from fence when ripping or ploughing.	Saw blade is not parallel with fence. (Heel Adjustment)
	Arm not perpendicular to guide fence.
	Dull blade or cutters.
3. Saw stalls when ripping or ploughing.	Fence not straight.
	Feed rate too fast.
	Wrong type blade.
	Arm too loose in base.
	Roller head too loose on arm.
	Yoke loose when clamped to roller head.
4. Saw blade scores lumber, not giving a good finished cut.	Saw blade is heeling.
	Arm too loose in base.
	Roller head loose in arm.
	Yoke too loose when clamped to roller head.
	Bent or dull blade.
	Not feeding saw properly.
	Using improper blade for finish cut desired.
5. Saw blade or Dado blades tend to push lumber to one side when cross cutting.	Saw blade is heeling.
	Arm too loose in base.
	Roller head too loose on arm.
	Yoke too loose when clamped to roller head.
	Fence not straight.
	Dull blade or cutters.
6. Cut depth varies from one end of stock to the other.	Table top not parallel with arm.
	Arm too loose in base.
7. 45° bevel cut not accurate.	Saw blade not perpendicular to table top.
	Arm too loose in base.
	Roller head too loose in arm.
	Yoke too loose when clamped to roller head.
	Bevel clamp knob loose.
8. Saw tends to advance over lumber too fast.	Table top not parallel with arm.
	Roller head not properly adjusted.
	Dull blade.
9. Saw does not traverse smoothly in tracks.	Not feeding saw properly.
	Roller head not properly adjusted.
	Dirty tracks.
10. Miter scale not accurate at various miter angles.	Bad bearings.
	Scale pointer not properly adjusted.
11. Clamping force not sufficient at miter angles other than 45°	Base clamp out of adjustment.

PRECUTTING (KERFING) THE WORK SURFACE

READ RULES FOR OPERATION ON PAGES 7 AND 8 BEFORE STARTING MOTOR

In cutting through material placed on the saw table the bottom of the saw blade should project to about 1/16" below the bottom of the material being cut. This causes it to cut into the table top, making kerf marks, unless kerfs already exist for the particular cut being made.

This section of the manual will cover the advance, or pre-cutting, of kerfs. This advance kerfing will facilitate your future cutting operations and blade position adjustments. As you continue to use the saw you will no doubt be cutting additional kerfs in the table, different ones from the normal pre-cut ones covered here. For this reason, you may want to cover the front section of table top with a piece of 1/4" plywood which can be replaced when the kerfs become too numerous. (Instructions for attaching 1/4" plywood are at the end of this section of the manual).

KERF No. 1 (Figure K1)

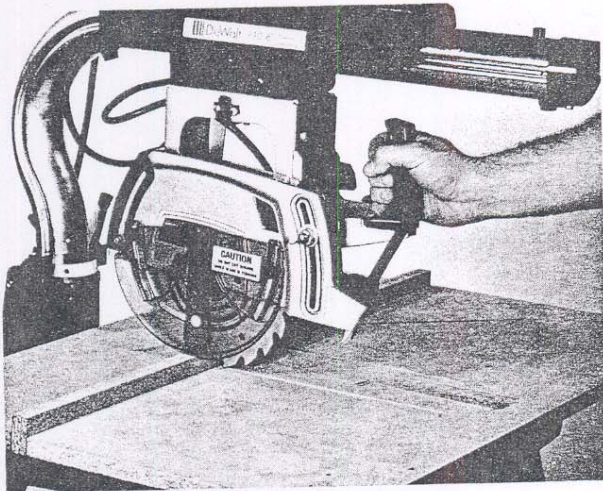

Figure K1

With motor "OFF", arm in crosscut position (0°), blade vertical (0°), and the saw elevated to its highest position, push the saw to the rear of the arm behind the fence. Turn motor "ON". Loosen the wing nut which locks the elevation. Grasp operating handle to hold saw back, and use elevating knob to lower the rotating blade until it cuts about 1/16" deep in the table surface.* Tighten wing nut. **CAUTION**—Saw will have a tendency to move toward you due to the "climbing" action of the rotating blade—you must hold it back. Begin moving the saw slowly toward you until you get the feel of the cutting action. Continue pulling saw toward you, cutting through the fence and making the kerf line until the saw reaches its limit of travel in the arm.

- * If you have covered the front part of the table with 1/4" plywood, a loose piece of 1/4" plywood can be "C"-clamped behind the fence so as to extend under the blade and enable you to judge the 1/16" deep cut for the front of the table.

KERF No. 2 (Figure K2)

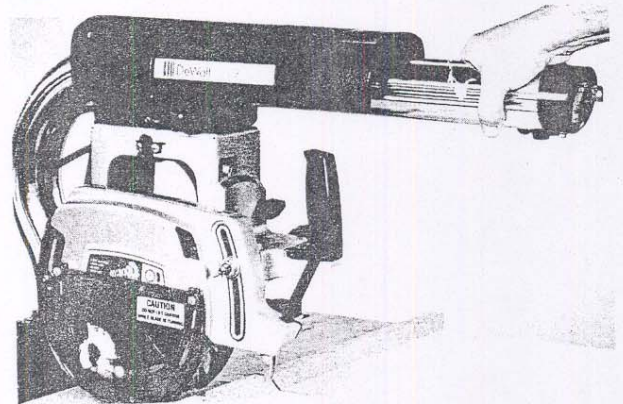

Figure K2

DO NOT MAKE THIS KERF IF YOU HAVE COVERED THE FRONT SECTION OF THE TABLE WITH PLYWOOD.

Kerf No. 1 is for normal 0° crosscutting, and when you return the saw behind the fence, the blade remains 1/16" deep in the table top. Therefore, to swing the arm right or left, you would have to elevate the blade. This elevating becomes unnecessary when you cut a curved trough in the table top behind the fence as follows:

Be sure the saw is all the way back on the arm. If it is not push the motor back with a few hard taps. This will bring the roller head in phase with the cover. Make sure the blade is about 1/16" deep in the kerf you have just cut. Lock the Rip Lock and turn the saw "ON". Release miter locking arm and start the arm moving to the right until it reaches its internal stop. The side of the blade will cut a curved trough. **CAUTION:** If the blade does not cut easily, it may be set too deep. Turn the motor "OFF", elevate saw slightly and begin again.

You can cut this trough to the left as well as the right if you wish, but most of your miter cuts, left hand or right hand, can be done on the right as explained later in this manual.

KERF No. 3

Set saw blade depth as you did for kerf no. 1. With the blade behind the fence, swing the arm right to the 45° miter position. Push down on miter locking arm and lock base clamp. Turn saw "ON" and pull it out to the end of the arm, cutting through the fence and making the 45° miter kerf. This kerf may also be made in the left hand miter position.

NOTE: The depth of kerfs Nos. 1 & 3 should be the same for their entire lengths. If they are not, the table needs adjustment. If the grooves are deeper in front, the front of the table is too high. If the miter kerf is deeper than the cross-cut kerf the table is too high on the right—assuming both cuts were made at the same saw elevation. If adjustment is needed, refer back to Table Adjustment in the Alignment section of this manual.

KERF No. 4 (Figure K4)

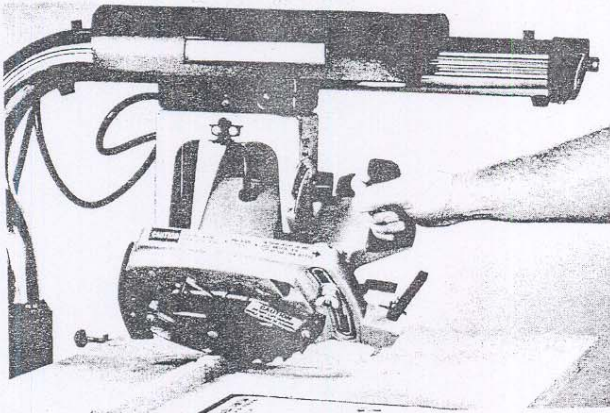

Figure K4

With the motor "OFF", arm in crosscut position (0°), blade set for a 45° bevel, and the saw elevated to its highest position, push the saw to the rear of the arm behind the fence. Turn the saw "ON" and set the blade cutting depth to about $1/16"$ the same way you did for kerf No. 1. Be sure elevating knob is tight. Pull the saw toward you cutting through the fence and making the kerf line until the saw reaches the end of the arm.

KERF No. 5

This kerf enables you to quickly convert from crosscutting to ripping operations. First, bring the saw out to end of the arm in the position shown in Figure K5, with the blade depth locked at about $1/16"$ deep in the crosscut kerf. Tighten the Rip Lock and release the Yoke Clamp Lever. Turn the motor "ON", press in the Yoke Locator Pin Handle and rotate the yoke clockwise 90° , cutting a $1/4$ -circle groove in the table (Figure K5A). (The Yoke Locator Pin Handle should be released after yoke rotation is started so that it can automatically stop the yoke at 90°).

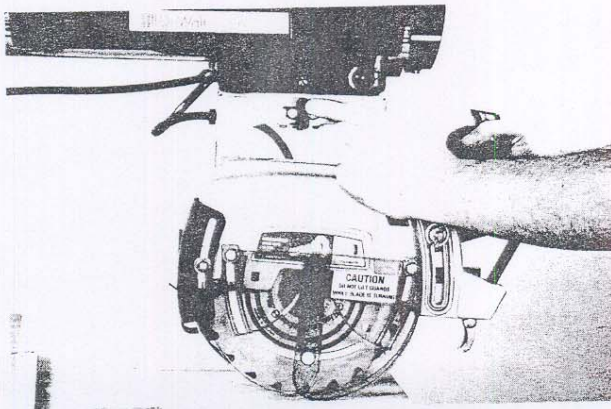

Figure K5

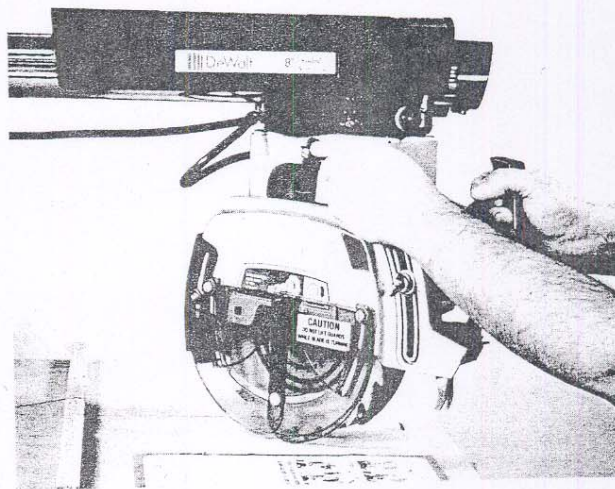

Figure K5A

The blade is now parallel to the fence, and with the motor still running, loosen the Rip Lock, lock the Yoke Clamp Handle, and push the saw slowly—cutting a trough—toward and just up to the fence (Figure K5B). The front guard must be raised to do this. Pull up on the tab as shown in Figure K5C. Turn the motor "OFF".

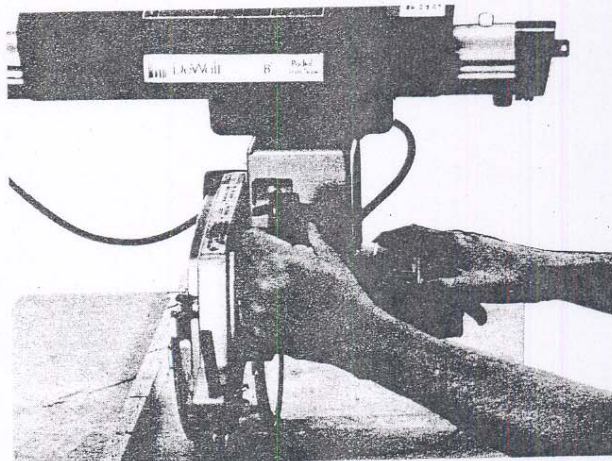

Figure K5B

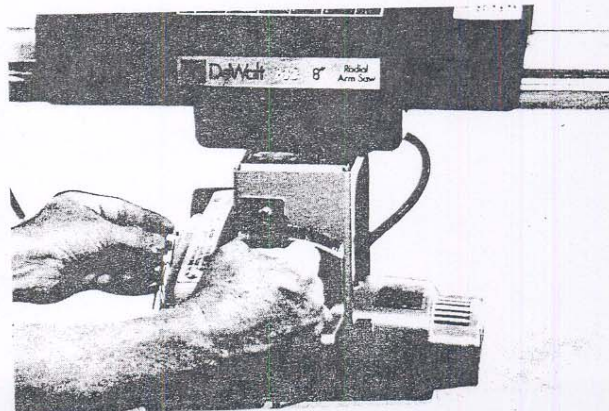

Figure K5C

Moving the saw back through the trough and 1/4-circle kerfs, bring the saw again to the position at the end of the arm as shown in Figure K5. Tighten Rip Lock and release Yoke Clamp Handle. Turn motor "ON" and temporarily press the Yoke Locator Pin Handle as you start to rotate the yoke counterclockwise (Figure K5D). Continue rotating until the Locator Pin stops the yoke, after a 1/4-circle cut, with the blade parallel to the fence. Now, with the motor still running—lock the Yoke Clamp Handle, Loosen the Rip Lock, and again slowly push the saw toward the fence, completing the rip trough kerf. Turn motor "OFF".

You have now cut into the work surface all basic, important kerf marks.

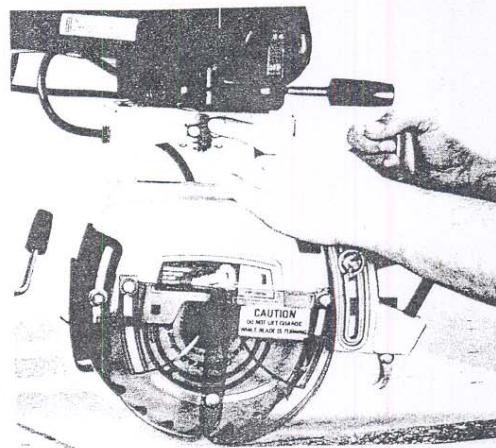

Figure K5D

1/4" PLYWOOD ON TABLE TOP

If you elect to cover your table top with 1/4" plywood, only cover it from the fence forward as it is unnecessary to cover the back board. Do not use masonite for a cover as it is too abrasive and will dull the blade too fast.

The plywood must be snug to the work table over its entire surface. Any warps or bumps will affect the accuracy of your cuts, particularly dado cuts. If you use brads for fastening, do not place them where the basic kerf marks will be made—if the blade hits a brad it will need sharpening at once.

The brads should be spaced about 5" apart over the entire surface.

Don't use glue as you will not be able to properly remove the plywood cover for replacement. If you use rubber cement, the top may be difficult to remove, but any solvent (lacquer thinner, acetone, etc.) will soften the rubber and the top will come off. Two-sided masking tape around the edges will also hold the top on. It is recommended that you use either rubber cement or masking tape.

BASIC KERF CUTS – APPROX. 1/16" DEEP

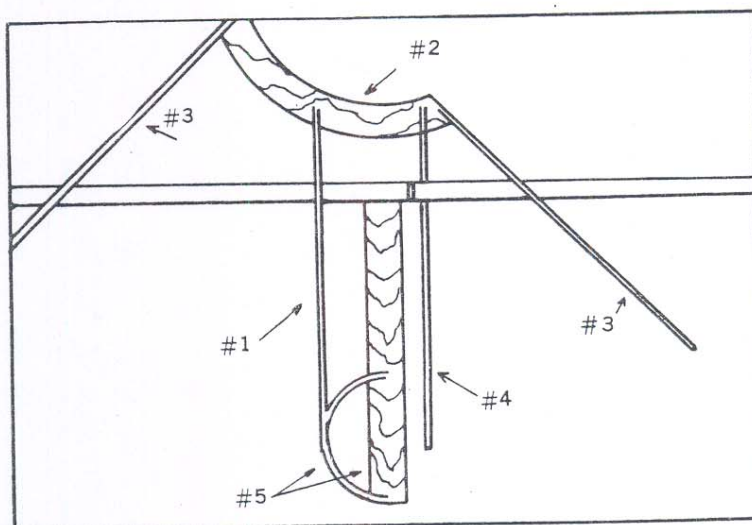

Do not attempt to cut any kerfs behind the fence IF the front of the table is covered with 1/4" plywood.

Figure K6

• OPERATING INSTRUCTIONS •

Observe and comply with the warning labels on the saw.

WARNING

FOR YOUR OWN SAFETY READ INSTRUCTION MANUAL BEFORE OPERATING SAW

1. Wear eye protection.
2. Keep hands out of path of saw blade.
3. Return carriage to full rear position after each crosscut type of operation.
4. Know how to reduce risk of kickback.
5. Use pusher board for narrow work.
6. Do not perform any operation freehand.
7. Never reach around moving saw blade.
8. Shut off power before clearing a stall or jam.
9. Make no adjustments until tool has stopped.

DANGER

TO AVOID INJURY DO NOT FEED MATERIAL INTO CUTTING TOOL FROM THIS END

SAWING—BASIC CUTS

CROSSCUTTING

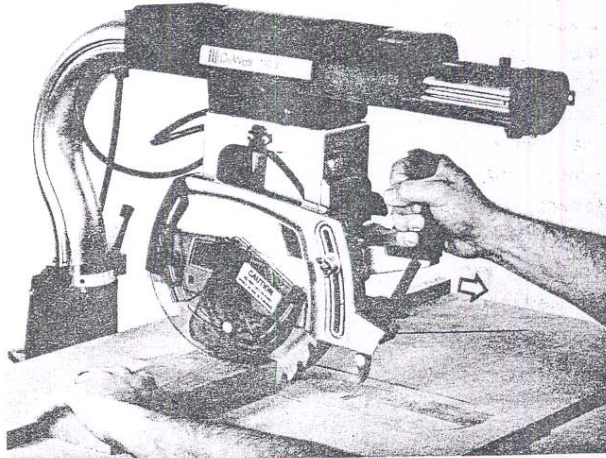

Figure S1

In cross-cutting you always pull the saw toward yourself and across the material which is held stationary against the fence. Never feed material into the saw when cross-cutting, and never cut when pushing the saw away from yourself. Always leave the anti-kickback assembly in place. Adjust it to just clear the workpiece in all crosscutting type operations.

With the motor "OFF", and the blade at 90° to the fence and perpendicular to the table, push the saw to the back of the arm behind the fence. Place the piece to be cut against the fence. Hold it firmly with four fingers on the top surface and the thumb tucked under the palm and against the edge facing you. **Keep hand well away from the line of cut!**

Turn the motor "ON". Grasp the saw handle firmly and pull the saw toward you until the piece is completely cut through, but not so far that the rear of the blade comes out of the cut in the material (Figure S1). This will prevent the loose piece from getting behind the blade and interfering with your returning the saw to the rear of the arm, which should always be done after each crosscut is completed. Turn the motor "OFF".

This basic cut is also called a "climb cut" because the rotation of the blade tends to hold the piece downward against the table and against the fence . . . the saw wants to "climb" over the piece but is held firmly down by the saw arm.

When making a cut, if the saw tends to move toward you faster than the blade can cut (possibly jamming in the wood), the rollerhead may need adjustment, as explained earlier in this manual. Also **jamming can be caused by pulling the saw through the cut too rapidly. If saw should jam turn motor off immediately.** Check the tightness of the roller head; if loose readjust, following the instructions on page 12.

Long Cross Cuts (Figure S2). With the fence in its normal position the length of the basic cross cut is about 10½". To cross cut wide lumber, first make this 10½" cut and turn the motor "OFF". Move the fence all the way back as shown in Figure S2. Slide the wood back against the fence keeping the blade centered in the cut you have just made. Turn the motor "ON" and extend the 10½" cut as needed or to the outward limit of saw travel in the arm. By turning the wood 180°, and repeating the above, cuts up to about 36" long can be made.

Repetitive Cross Cuts (Figure S1). When making many cross cuts the travel of the blade may be limited to the same travel each time by placing 2 pieces of ¾ inch diameter dowels in the circular arm track sections (one on each side of the arm) between the face of the arm cover and the arm end cap. These dowels are best held in place with wide rubber bands such as those cut from an old bicycle inner tube.

Use common sense, think all operations through before starting, and be alert.

Review the "Rules For Safer Operation of Stationary Power Tools" and "Maintenance and Operation" sections. (See index)

Keep saw in good adjustment and alignment; use only sharp, free-cutting tools and accessories that were designed for your machine. These precautions will help reduce the possibility of jam-ups or kickbacks.

Never perform any operation "free hand" (i.e. supporting the workpiece by hand alone). The workpiece must always be solidly supported or guided by the fence or supporting jig or fixture to prevent any unexpected movement.

If the sawblade or cutter becomes stalled or lower guard becomes jammed - **Turn off power immediately.** Never attempt to free a jam up without first turning power off. Remove workpiece and re-check machine alignment. Adjust as necessary.

Never cycle the tool "on" and "off" rapidly, as forces can be produced which will loosen the arbor nut.

If the arbor nut should ever loosen, allow the blade to come to a complete stop and re-tighten the arbor nut securely, but not excessively.

Read through and study the pictorial operating instructions which follow for further instructions before using your new DeWalt saw.

CAUTION
 ALWAYS WEAR PROTECTIVE GOGGLES.
 WEAR DUST MASK IF OPERATION IS DUSTY.

To determine the proper length of the dowels, pull the saw (with the motor "OFF") to the position where the piece would be completely cut through if you were cutting, and measure the distance between the face of the arm cover and the arm end cap. Cut both dowels to this length.

Always make sure that the saw blade is returned to its position completely behind the fence and turn motor off after each cross cut is completed.

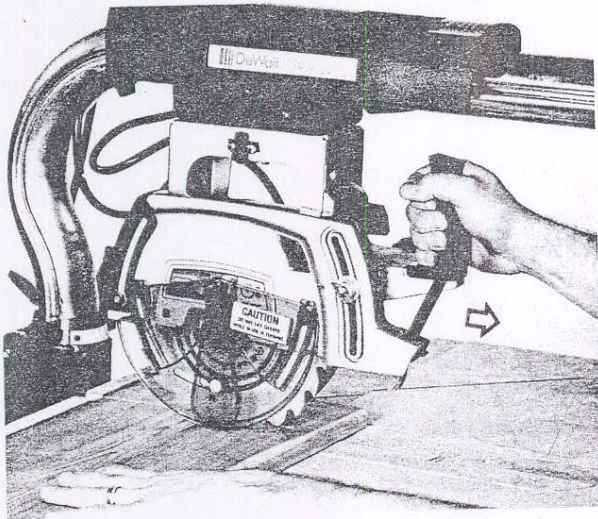

Figure S2

MITER CUTS

1. With the motor "OFF", loosen base clamp handle, position the saw arm 45° to the right with the blade in back of the fence. Close miter locking arm into groove. Tighten base clamp handle.
2. Place material to be cut against the fence.
3. Turn the motor "ON". Pull saw forward (Figure S3) only the distance necessary to cut through the material, and then return saw to back of fence. Turn motor "OFF".
4. If a longer miter cut is needed, move the fence back behind the spacer board. (Figure S2). Place the piece being cut against the fence with the blade centered in the cut previously made with the fence in normal position. Turn motor "ON" and pull saw forward the distance needed to complete the cut. Return saw to rear of arm and turn motor "OFF".

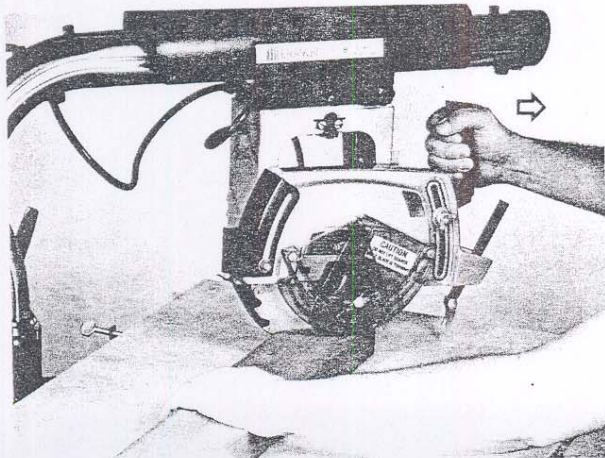

Figure S3

MITER CUTS (continued)

Right and left hand miter cuts for corners or frames are best made with a simple miter jig. With this jig the saw arm can remain in the 45° right miter position for cutting both opposing 45° angles. FIRST, place the piece to be cut against the fence and then "C"-clamp a piece of plywood, with at least one accurate 90° corner, in the position shown in Figure S4. Make the cut. The opposite miter is cut by using the edge of the plywood as a fence, see Figures S5 and S6.

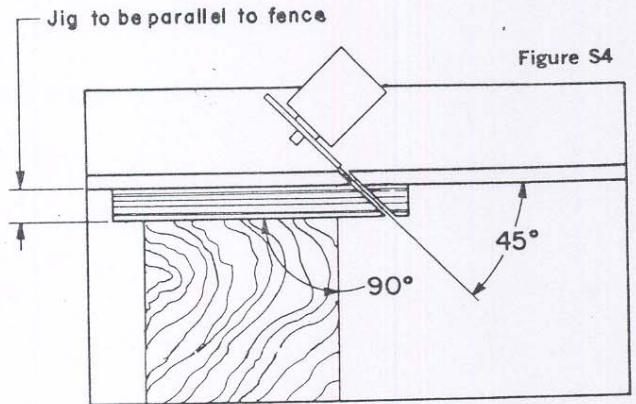

Figure S4

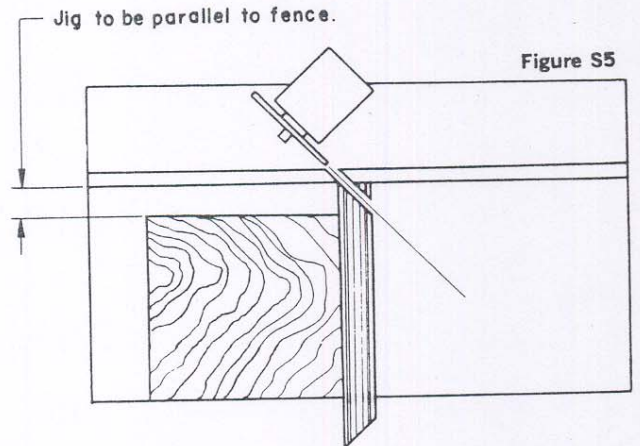

Figure S5

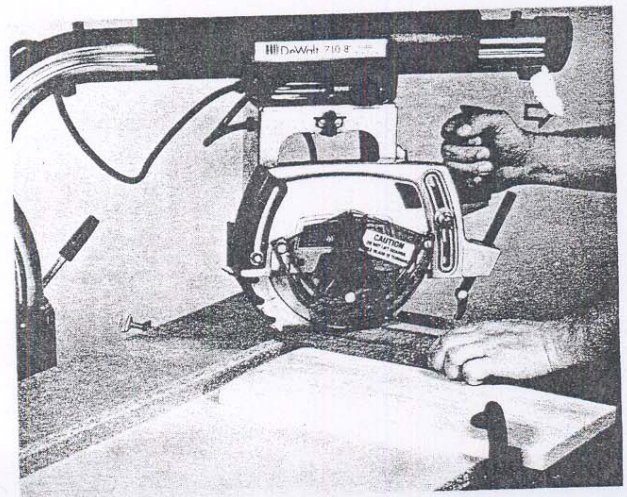

Figure S6

For moulding frames, if you want to "compound" (miter and bevel) the cut, bevel the two 90° edges of the plywood at the angle to which you want the frame to pitch. Make the cuts as before, but hold the moulding flush against the beveled edge of the plywood.

For maximum length miter cuts with the arm in the LEFT-HAND miter position, it is suggested that you rip two 3/4" thick strips (one 2" wide, one 5 1/8" wide) to replace the rear table board as shown in Figure S7. The fence can then be located as in Figure S8, when needed for longer left hand miter cuts.

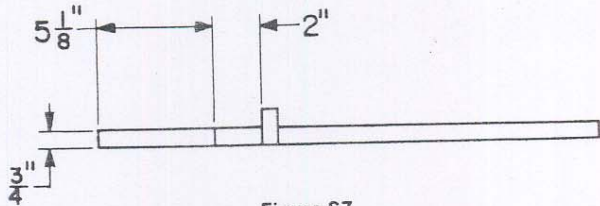

Figure S7

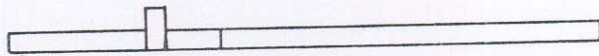

Figure S8

BEVEL CROSSCUTS

With the motor "OFF" and the blade perpendicular to the table, elevate the saw to its highest position and tilt the blade to the desired bevel angle. (If the blade strikes the table, refer back to Table Adjustment and lower the table). Lock the bevel lock and push saw behind the fence. Turn the motor "ON" and lower the blade until it cuts about 1/16" deep in the table top. Lock the elevation. Pull the saw forward, cutting a clearance kerf through the fence and into the table top. Return saw to back of fence and turn motor "OFF". Pre-cut not necessary if bevel is 45° as it was cut with kerf cuts.

Hold the material to be cut against the fence with one hand placed well away from the line of blade travel. Turn motor "ON" and pull the saw through the cut only as far as necessary to cut through the material (Figure S9). Return saw behind fence and turn motor "OFF".

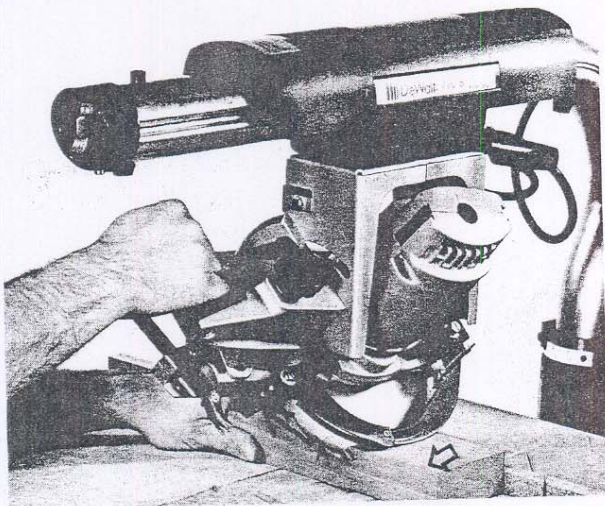

Figure S9

NOTE: If it ever becomes necessary to manually raise the rear metal guard, TURN MOTOR "OFF", and press down on either of the two lift tabs "A" in the above illustration.

COMPOUND (BEVEL-MITER) CUTS

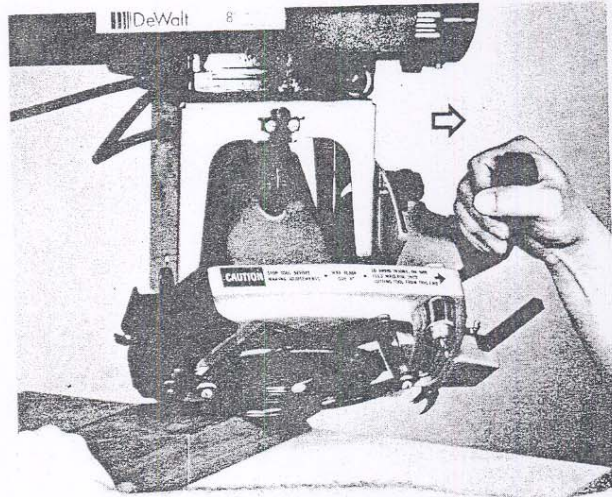

Figure S10

The procedure for making a compound cut is the same as for a bevel crosscut except that the arm is moved to the right or left from 0° to any desired miter angle up to 45°. The bevel angle of the blade is also adjustable from 0° to 45°. See Figure S10.

A popular setting for picture frames is a 30° bevel and a 35° miter, or a 35° bevel and a 30° miter. These combinations of 30° and 35° give an interesting pitch to the frame.

RIPPING

Kickbacks can occur when the workpiece binds between the saw blade and the fence during a ripping type operation. Such action could cause the workpiece to be ejected from the machine and thrown violently back towards the operator.

Never stand, or permit someone else to stand in line with the work being ripped due to possible kickbacks.

The anti-kickback fingers must be kept sharp, free moving and correctly adjusted to insure proper operation.

Use extra care when ripping material that is twisted or bowed which can rock on the saw table and cause pinching or binding. Place the wood on the table in such a manner as to minimize rocking.

A pusher board should be used when ripping narrow work (i.e. less than 3 inches or so between the blade and fence). The pusher board should be made from clear, straight grained lumber as shown below.

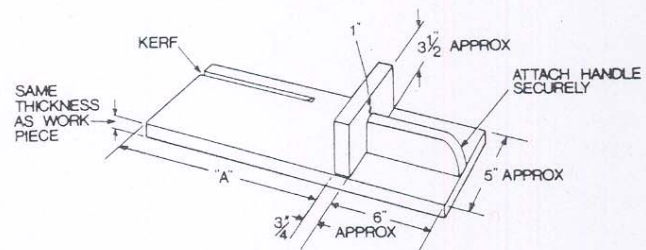

Dimension "A" must be such that the workpiece is fed completely past the blade but short enough to prevent the pusher board from passing under the anti-kickback device.

The pusher board should be pre-kerfed prior to use, for every new width of rip a new or re-worked pusher board must be used. Do not rip workpieces shorter than 12" in length.

Use extension guard for blade and anti-kickback device in all ripping operations.

When ripping, the lumber is fed into the blade, and the first contact with the blade is the opposite blade edge from that first contacted in crosscutting. Ripping is a "feed" cut, while crosscutting is a "climb" cut. With the fence in its normal location, use the "IN-RIP" position (Figure S11) for cuts up to 7" wide. Use the "OUT-RIP" position (Figure S12) for cuts up to 12-1/4" wide. The fence can be moved to the back of the table for rips up to a maximum of 20" in the "OUT-RIP" position.

To set up for ripping, with the motor "OFF", rotate the saw into the in-rip or out-rip position as desired. Let the index pin fall in place. Tighten the yoke clamp handle. (Always feed material from the end of the movable guard extension—never feed from the end with the operating handle and the anti-kickback device. Remember to raise the front, lower blade guard to clear rip fence if needed). Lower the blade until the teeth fit into the dished kerf previously cut. Move the saw on the arm and lock the rip-lock when the distance from blade to fence equals the width wanted. Lower the guard extension until it is about 1/8" above the material being cut (Figure S11). Lower the anti-kickback assembly so that the fingers hang about 1/8" below the top surface of the material to be cut. **To test slide the material under the anti-kickback fingers—try pulling material in opposite direction. The anti-kickback fingers should grab it; if not, readjust assembly until they do.** Remove the material.

Turn motor "ON" and feed the material under the guard extension, holding one side of the material snug against the fence. Feed the material evenly into the blade—not too fast—give the blade a chance to cut. If you do not have plenty of room between the blade and the fence to push the material completely through the cut, use a pusher stick—Figure S13.

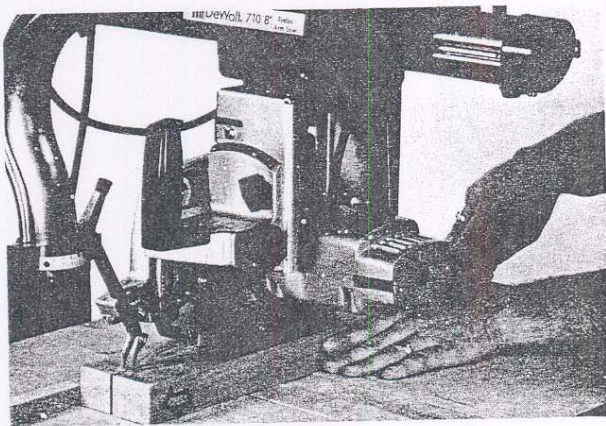

Figure S11 (In-rip position)

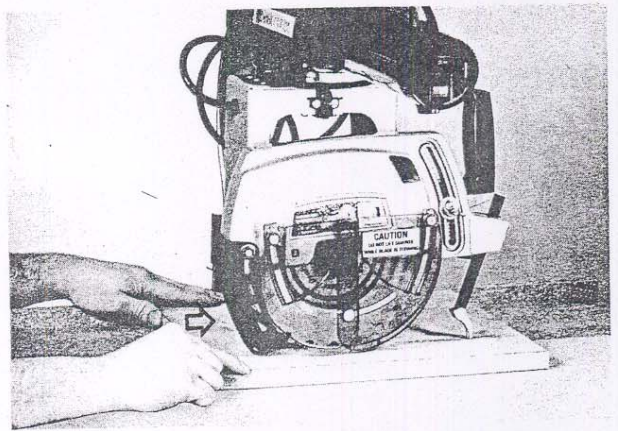

Figure S12 (Out-rip position)

BEVEL RIPPING

The procedure for bevel ripping is the same as for straight (0°) ripping except that the blade is set at an angle between 0° and 45° (Figure S13). **Set and test the anti-kickback device the same as in RIPPING** even though only one of the fingers will take the main "bite", if needed. Remember to raise the front, lower blade guard to clear rip fence if needed.

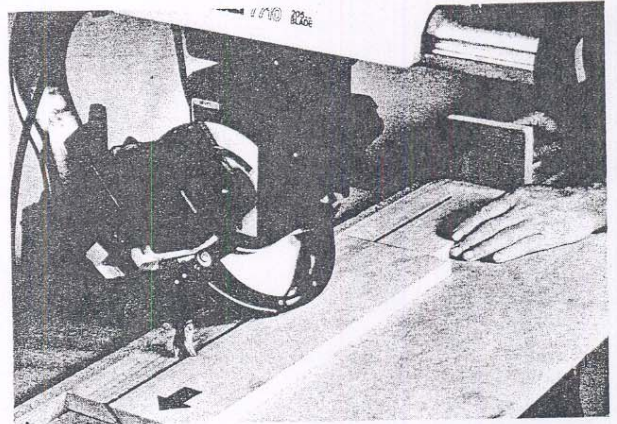

Figure S13

CAUTION: NEVER FEED MATERIAL FROM THE SIDE ON WHICH ANTI-KICKBACK DEVICE IS LOCATED.

DADO & PLOUGH CUTS

(CUTTING GROOVES)

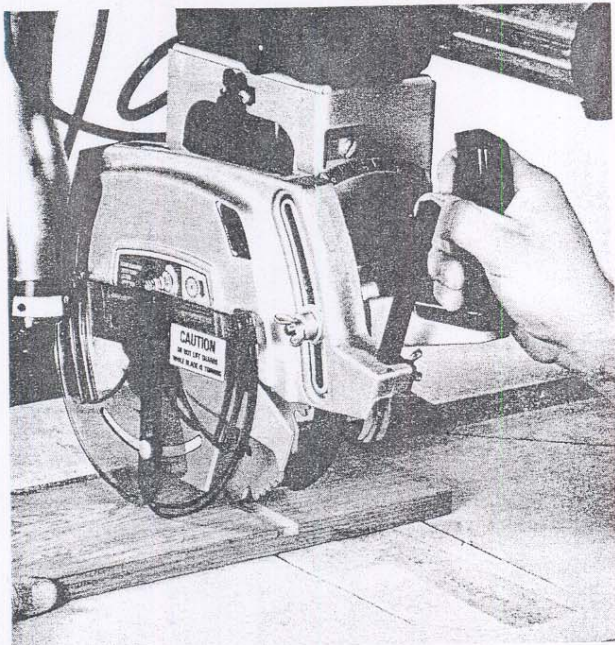

Figure S14

A "Dado" is a groove across the wood grain (crosscut) (Figure S14). A "Plough" is a groove with the wood grain (rip) (Figure S15). These cuts can be made to any width with a regular saw blade by making one cut next to another until the desired width is achieved. The depth of the groove is controlled by the amount of elevation given to the saw blade.

A 6" diameter Dado Set (or Dado Head) will make dados or ploughs in widths from 1/8" to 13/16" in one cut. The Dado set consists of 2 saw blades 1/8" thick, 4 chippers 1/8" thick, and one chipper 1/16" thick. The 2 blades, when placed together cut a groove 1/4" wide. As chippers are placed between the blades the cutting width will be increased accordingly. The chippers are "swedged" (their cutting ends are flared out), and when placing them between the blades, the swedges must fall in the tooth gullets of any blade next to them (see Figure S16). When using 2 or more chippers their ends can be spaced evenly around the circumference or not—it doesn't matter. As you make the dado wider you will have to remove the spacer washers on the saw arbor (see Figure S17).

The easiest method for setting the proper depth of cut, is to measure the thickness of the lumber and subtract from this the depth of the desired dado. The result will be the dimension that the bottom of the dado head should be set above the table top.

Follow the same procedure in making cuts with the dado head as you would with a regular saw blade, **although slower cutting is recommended**. When ploughing, be sure to lower the guard extension to 1/8" above the wood and lower the anti-kickback assembly so that the fingers hang to 1/8" lower than the top surface of the material being cut. **Test the grabbing action of the fingers as previously explained under RIPPING**. Also, when feeding material into a plough cut, push the wood down as well as forward, as the dado head will have a tendency to lift the wood as it cuts.

CAUTION
ALWAYS WEAR PROTECTIVE GOGGLES.
WEAR DUST MASK IF OPERATION IS DUSTY.

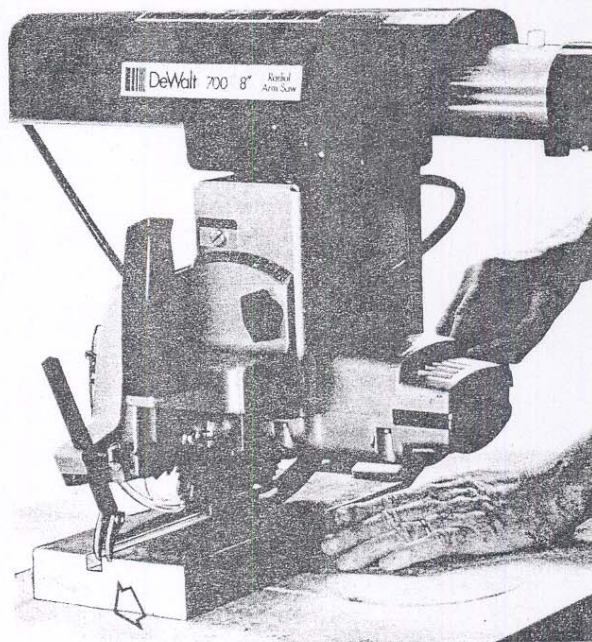

Figure S15

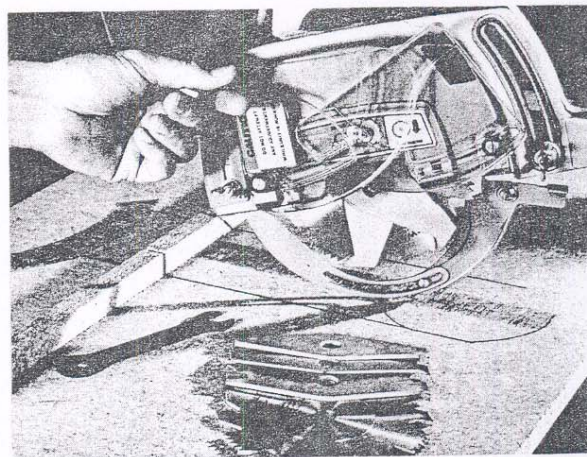

Figure S16

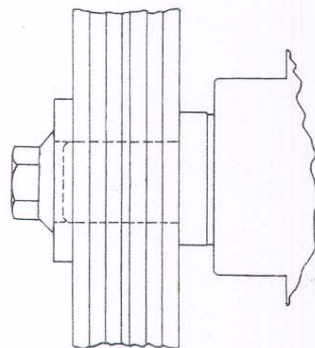

Figure S17

If saw blade jams, check the tightness of the roller head. If loose, readjust, following instructions on page 12.

SAW BLADES & ACCESSORIES

Your saw is equipped with an 8" blade which rotates at 5200 RPM and will enable you to cross cut 2-7/8" deep. Using the proper blade is most important and no matter what type of blade you use it's **wrong** if it is **not sharp**. A dull blade can do harm to the material you are cutting, to your DeWalt saw, and last but not least to you. A sharp blade is the most efficient.

The proper blade will produce the best results. We suggest three (3) basic blades. First, the one which comes with the saw—a COMBINATION BLADE for all around cutting of hard or soft woods. It will lose its edge quickly if used on plywood, chipboard, masonite, plastics, dirty lumber, and painted or varnished boards. This blade makes an ordinary saw cut that usually must be sanded or planed if a smooth finish is desired.

Second, to cut plywood, chipboards, masonite, etc., use a PLYWOOD BLADE (small teeth). It will hold an edge longer, does not splinter plywood, and cuts quite smoothly.











Third, to cut a finished or planed edge, a HOLLOW GROUND PLANER blade is best. (Not for plywood, masonite etc.) It requires more power to drive a hollow ground blade since this blade has a tendency to burn the wood. It must be kept very sharp and clean.

To assist you in selecting blades a saw blade selection chart is shown below.



CAUTION

Recommended Blades and Accessories for your Radial Arm Saw are listed on this page. The use of any other accessory or attachment might be hazardous.

SAW BLADE SELECTION CHART

STANDARD QUALITY BLADES		Outstanding value for the price. These blades are made from the highest quality spring steel. The blades are then coated with a hard-baked enamel to resist gum and resin build-up on the teeth during cutting. Available in the five most popular types and sizes to cut all types of wood products.			
	TYPE	DESCRIPTION	NO.	DIA.	TEETH
	PLYWOOD	Finely ground teeth give smooth splinter-free cuts in plywood, panelling, veneers, Cellctex, thin plastics, etc. Will make smooth crosscuts and miters equally well.	73-048	8"	150
	MASTER COMBINATION	General-purpose blade designed for ripping, cutting off and mitering wood where a fine, smooth cut is needed. No sanding is necessary.	73-058	8"	60
	CROSS-CUT	Specifically designed for smooth fast cutting across the grain of both hard and soft woods where finish is an important factor. May also be used for rip and crosscuts on extremely hard woods.	73-028	8"	100
	COMBINATION	Chisel tooth configuration makes this the fastest cutting blade in our Standard Quality line. Specifically designed for general purpose ripping and cross-cutting where the finish of the cut is not critical.	73-008	8"	22
	FRAMING/ RIP	An all-purpose blade for smooth, fast cutting in any direction. Rips, cross-cuts, miters, etc. One of the most popular all-purpose blades available. Gives especially fast, smooth finishes when cutting with the grain of both soft and hard woods.	73-038	8"	40
PREMIUM QUALITY BLADES		Hard, industrial chrome plated (not just decorative chrome plating) to give twice the cutting life of unplated blades. Plating improves wear resistance, protects against rust and other corrosion, reduces gum or resin build-up on teeth. Your best buy in top quality blades.			
	COMBINATION	Chisel tooth configuration means this blade is the fastest cutting blade in our line. Specifically designed for general-purpose ripping and cross-cutting where the finish of the cut is not the most desired effect.	73-108	8"	22
	FRAMING/ RIP	An all-purpose blade for smooth, fast cutting in any direction. Rips, cross-cuts, miters, etc. One of the most popular all-purpose blades available. Gives especially fast, smooth finishes when cutting with the grain of both soft and hard woods.	73-138	8"	40
	HOLLOW GROUND PLANER	Specially ground for satin-smooth finish cuts (crosscuts, rips and miters) in all solid woods. A professional quality blade for use in cabinet work, furniture, etc. Specifically designed to make extremely smooth cuts in wood 1" thick and thicker. Eliminates need for sanding.	73-158	8"	60
	*CARBIDE TIPPED (8 tooth)	Specially designed for cutting tough-to-cut materials such as: Transite, Cemesto board, asbestos, Formica and Masonite. Will also cut wood where speed and finish are not critical. Each blade has tungsten carbide permanently braised on each tooth for up to 15 times the cutting life without sharpening.	73-178	8"	8
	HOLLOW GROUND PLYWOOD	Special taper grinding on the sides of this thin rim blade gives an absolutely smooth cut in plywood, veneers and laminates, etc. Can be used in crosscutting and mitering for a professional finish on all types of cabinet work. Eliminates need for sanding.	73-148	8"	176
	CROSS-CUT	Specifically designed for smooth, fast cutting across the grain of both hard and soft woods where finish is an important factor. May also be used for rip and crosscuts on extremely hard woods.	73-128	8"	100

ACCESSORIES

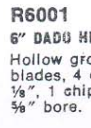
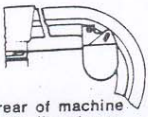
				
35021 DELUXE MACHINE STAND	R1205 ADJUSTABLE FENCE STOP Clamps to fence for repeated accurate length cutting. Fine adjustment screw gives 1/4" for each full turn.	R6024 6" DADO HEAD SET Flat ground (2 blades, 4 chippers 1/8", 1 chipper 1/4") 5/8" bore.	R6001 6" DADO HEAD SET Hollow ground (2 blades, 4 chippers 1/8", 1 chipper 1/4") 5/8" bore.	R1438 AUTOMATIC RETURN DEVICE Fastens to rear of machine arm. Automatically returns saw blade to rear of guide fence after cut.

FANCY CUTS

1. LATTICE WORK

Make a series of evenly spaced gaining dado cuts at any angle, slightly deeper than $\frac{1}{2}$ the stock. Repeat this operation on the other side and a lattice will appear. If the miter angle is 45° the holes in the lattice will be square. If any other angle is used, the holes will be diamond shaped (Fig. T1).

2. CASTELLATED MOULDINGS

Make a series of dado cuts cross-grained and evenly spaced (Fig. T2). Rip off this piece (use a hollow ground blade) into strips of moulding at any desired width (Fig. T3).

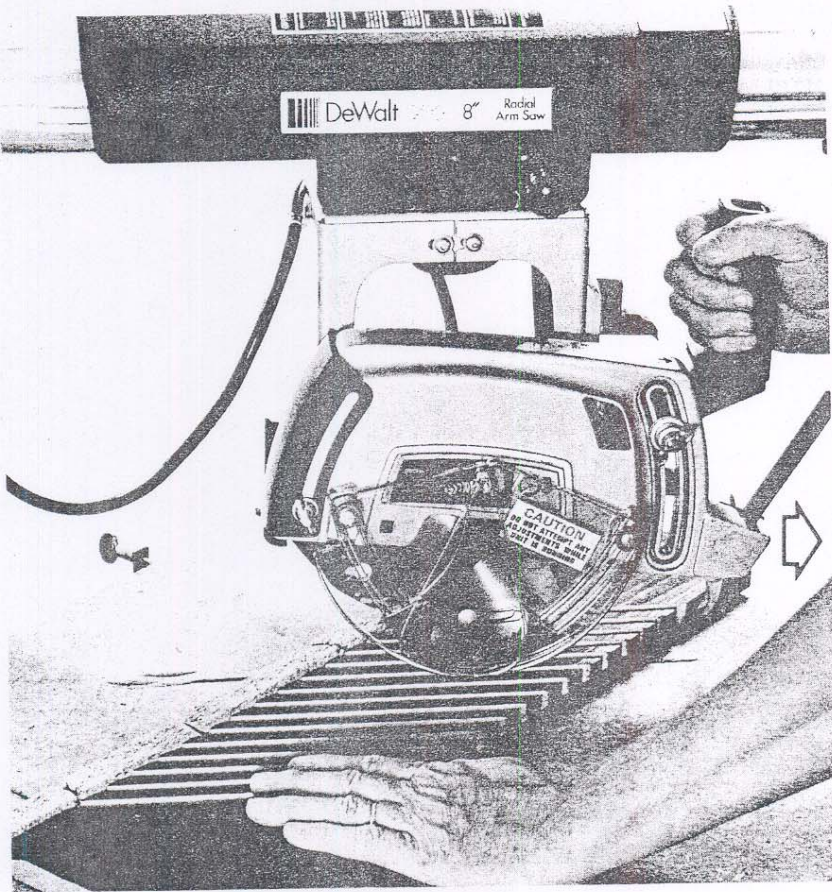

Figure T1

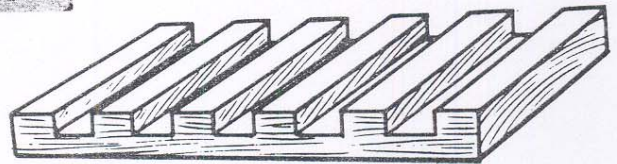
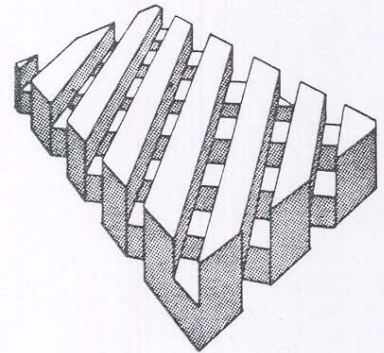

Figure T2

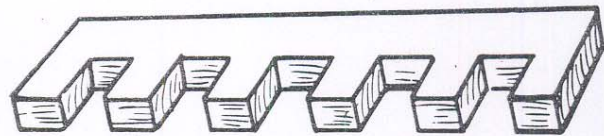

Figure T3

5. KERFING or BENDING WOOD

If you rip a piece of wood thin enough it will bend quite easily. Wet this piece and it will bend even more easily and have less tendency to crack. By cutting a slit cross-grained and leaving a thin piece of wood on the bottom, you can bend the wood at this cut until the slit or kerf is closed at the top (Fig. T4). By cutting several slits, one alongside the other, the piece will appear to bend (Fig. T5). To calculate the number of slits required to bend the lumber 90° , measure the angle of the first bend and divide it into 90° . An easier method is by trial and error on a piece of scrap of the same thickness. Once you determine the number of cuts, you will always get a bend of 90° regardless of the distance between cuts. The wider the cuts are spaced, the larger the arc (Fig. T10). When the kerf cuts get wider than $\frac{1}{4}$ " apart, the effect of the curve changes to straight sections at an angle to each other (Fig. T10). If wide arcs are desired, the number of kerf cuts needed can be increased by one of two methods or by a combination of both. Use a blade with a thinner kerf (Fig. T11). Use a thicker piece of lumber (Fig. T12). Glue an extra piece of lumber to the back of the section to be kerfed. By doing this you can artificially increase the thickness of the lumber only at the place you want it (Fig. T13). The piece to be curved can be mitered, rabbeted or grooved on the inside but this must be done **before** you kerf it (Fig. T14). Once the piece is bent the holes from the kerf cuts are filled with sawdust and glue forming a solid curved piece of lumber when the glue has hardened. All sides of the curved piece can be veneered to give a smooth solid appearance. If the cuts are made at an angle, the piece of lumber will spiral and the pitch of the spiral will be the same as the angle you cut (Figs. T-15 & T-16).

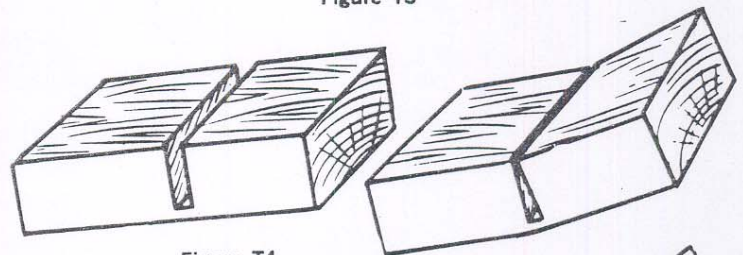

Figure T4

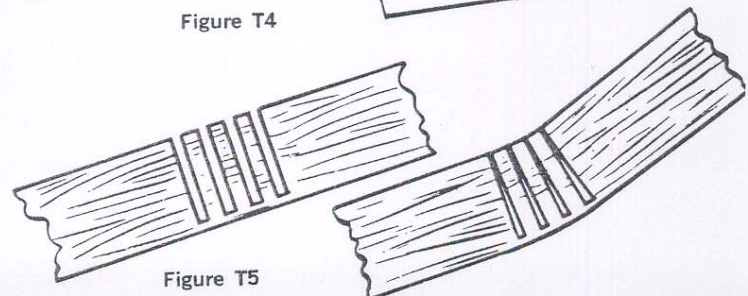

Figure T5

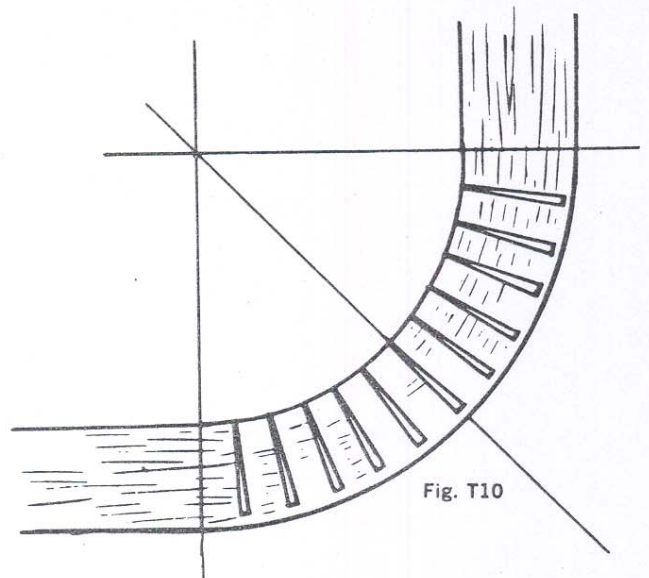
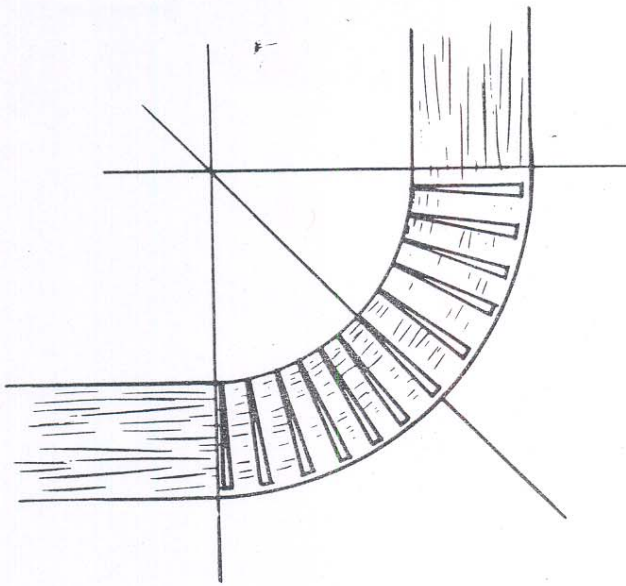

Fig. T10

Fig. T11

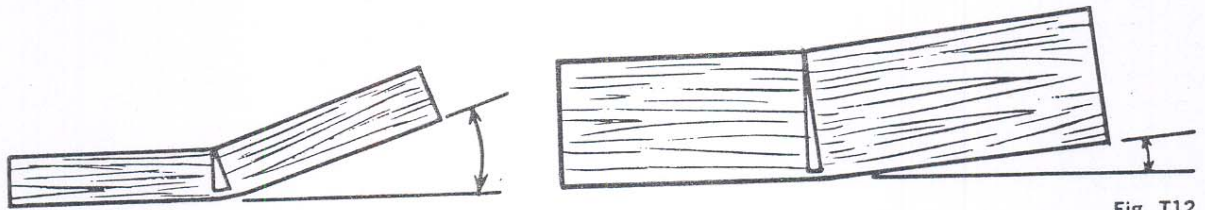
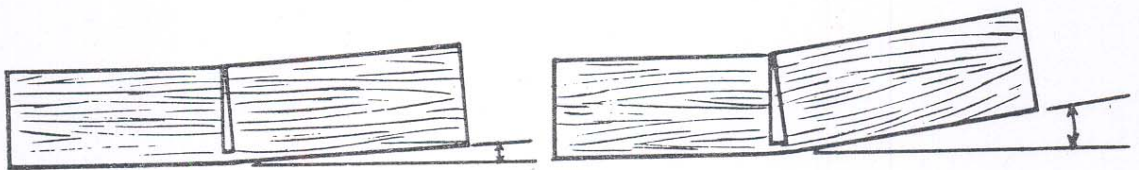

Fig. T12

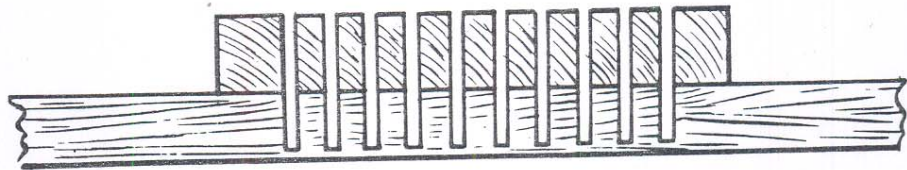

Fig. T13

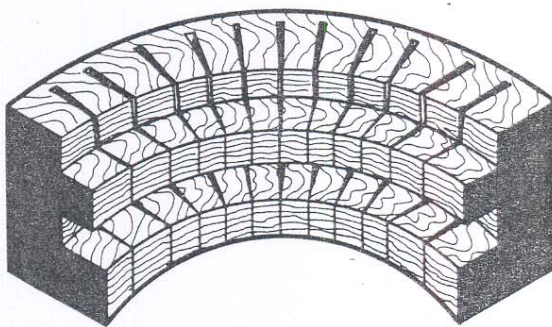

Fig. T14



Fig. T15

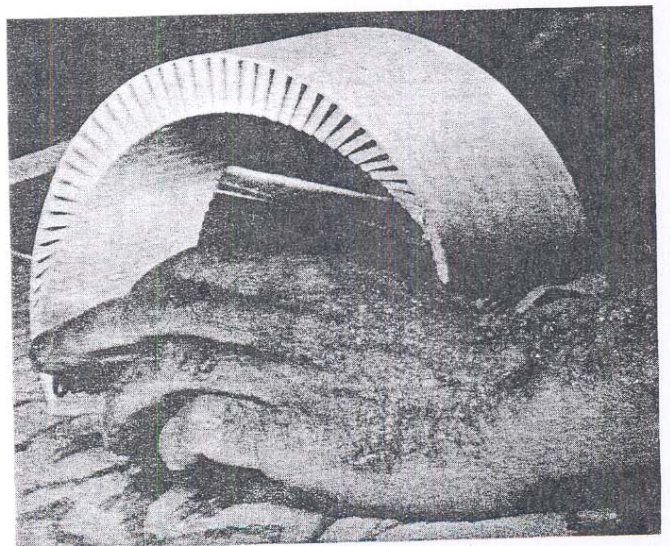
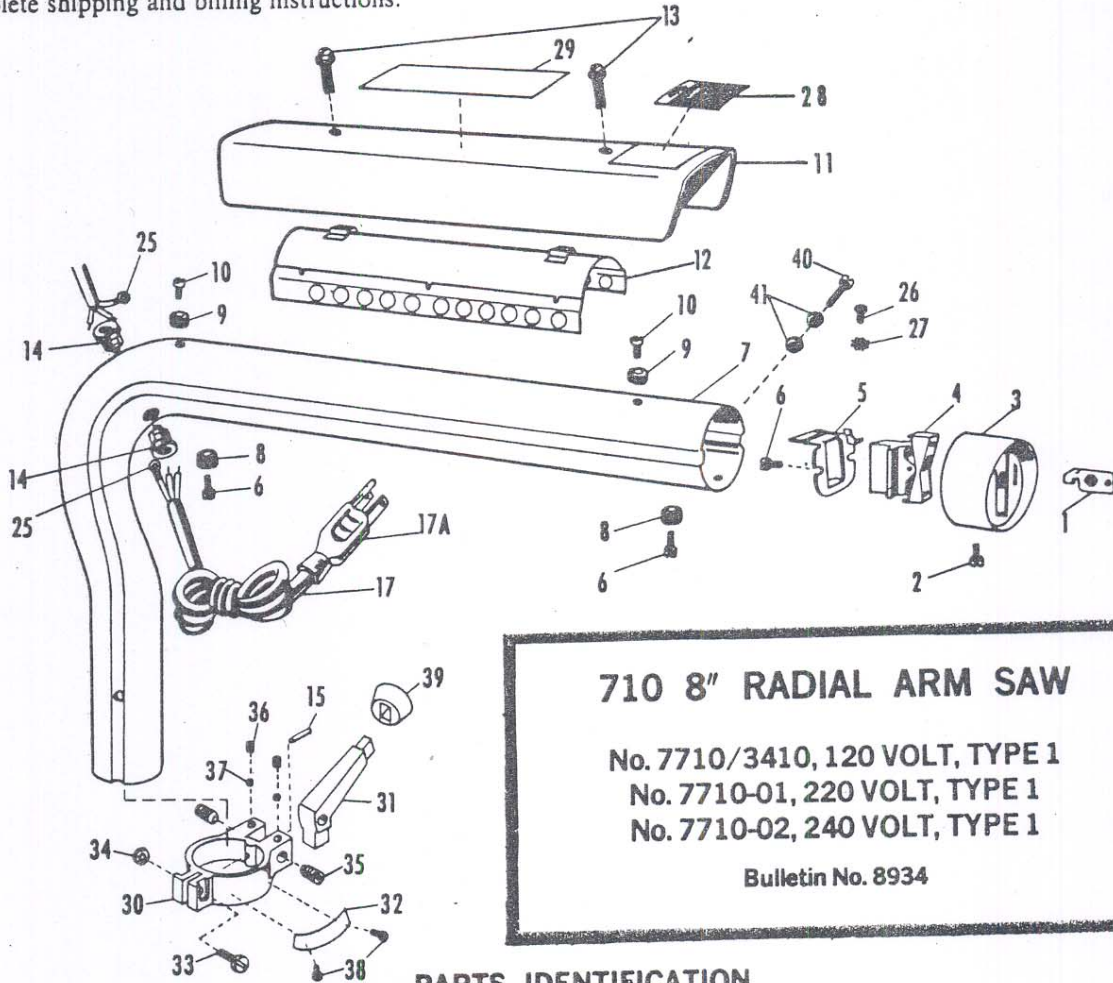

Fig. T16

PARTS LISTS AND ORDERING INSTRUCTIONS

Order only genuine Parts from your Black & Decker or DeWALT Authorized Service Centers. With your order be sure to include:

1. Name of manufacturer. DeWALT.
2. Complete machine identification data (from name plate on motor).
3. Complete motor identification data (from motor name plate).
4. Quantity, part number, and description of parts required.
5. Complete shipping and billing instructions.



710 8" RADIAL ARM SAW
 No. 7710/3410, 120 VOLT, TYPE 1
 No. 7710-01, 220 VOLT, TYPE 1
 No. 7710-02, 240 VOLT, TYPE 1
 Bulletin No. 8934

PARTS IDENTIFICATION

Index No.	Part No.	Description	Qty.	Index No.	Part No.	Description	Qty.
1	69302	Key	1	17	36480-98	Cord Set (120 Volt)(7710) 444548-98	1
2	99319-05	10-24 x 5/16 Pan Hd. Machine Scr. & Lock Washer	1		121449	Cord Set (220 Volt)(7710-01)	1
3	69295-01	End Cap	1		234900-01	(7710-02)	1
4	70047-04	Switch	1	17A	39506-01	Attachment Plug (120 Volt)(7710)	1
5	69301	Switch Lock	1	25	34289	Terminal	1
6	69408	10-32 x 7/16 Fil. Hd. Screw	4	26	39001	8-32 x 5/16" Self Tap Screw	1
7	94873-01	Arm	1	27	99478-03	External Tooth Lock Washer	1
8	69298	Bumper	2	28	96683-	Caution Label 122027	1
9	85874	Bumper	2	29	121677	Instruction Label	1
10	69294	8-32 x 7/16 Fil. Hd. Self Tap Scr.	2	30	121652	Arm Collar	1
11	85192-03	Shroud & Nameplate (Includes item 28 & 29)	1	31	121653	Locking Arm (Miter)	1
12	74993	Balls, Retainers & Brackets	1	32	121655-	Miter Scale 121935	1
13	74997	10-16x 3/4 Pan. Hd. Self Tap. Screw	2	33	80638	5/16-18 x 3/4 Fill. Hd. Screw	1
14	94511	Strain Relief	2	34	80467	5/16-18 Hex Nut	1
15	48731	1/8 x 5/8 Pin	1	35	121657	1/2-20 x 3/4 Cup Point Set Screw	2
				36	82387	1/4-20 x 1/4 Socket Set Screw	2
				37	103522	Set Screw Slug	2
				38	80488	6-32 x 1/4 Self Tapping Screw	2
				39	80534	Cap	1
				40	1789	Screw, 8-32x1/2 (7710-02 only)	1
				41	407	Hex. Nut (7710-02 only)	2

Not Shown: 99056-11 Hex. Wrench (Required for some units)

YOKE & CARRIAGE

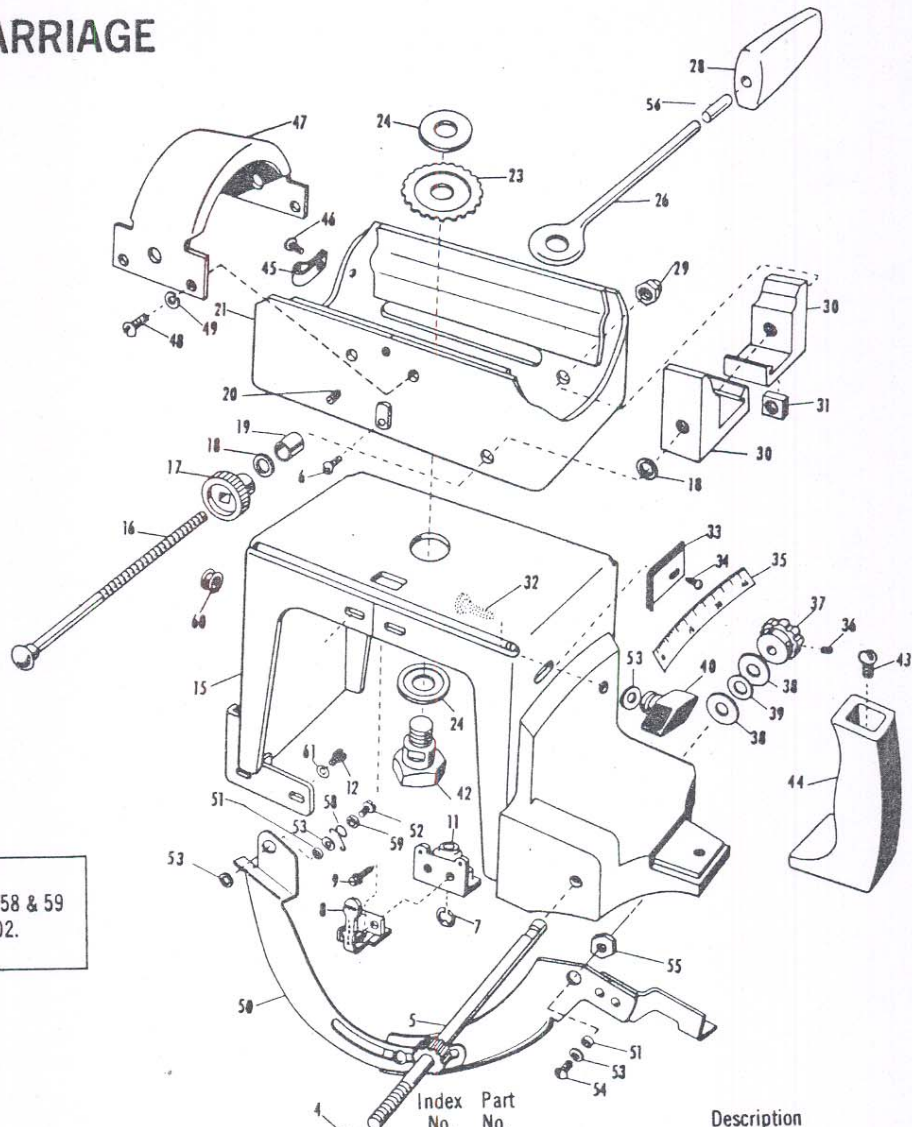

* Items 50, 51, 52, 54, 55, 58 & 59
Not Used on 7710-02.

PARTS IDENTIFICATION

Index No.	Part No.	Description	Qty.
1	93907	Wing Nut	1
2	69292	Cupped Washer	1
3	121640	Prevailing Torque Nut	1
4	69278	Nylon Washer	1
5	69290	Elevation Shaft & Gear	1
6	99256-10	#10-32 x 5/8 Mach. Screw	1
7	60325-01	Retaining Ring	1
8	121639	Rip Index Actuator	1
9	121497	#10 x 3/4 Self Tap Screw	2
11	121469	S/A Rip Index	1
12	99257-08	#1/4-28 x 1/2 Pan Hd. Scr.	1
		(7710-02)	2
15	91538-05	Yoke (7710-00, 7710-01)	1
	91538-06	Yoke (7710-02)	1
16	69303	#5/16-18 x 5 Carriage Bolt	1
17	69281	Riplock Grip	1
18	11078-01	Washer	2
19	69409	Spacer	1
20	21192	#1/4-28 x 1/4 Set Scr.	2
21	121488	Carriage	1
23	121475	Lock Washer	1
24	121476	Clamp Washer	2
26	92156	Clamp Handle 122044	1
28	70261	Handle Grip (Inc. 56)	1
29	69287	Acorn Nut 5/16-18	1
30	72748	Rip Lock Block	2
31	99362-03	#5/16-18 Square Nut	1
32	55131	#1/4-20 x 7/8 Carriage Bolt	1
33	69306	Bevel Pointer	1
34	99271-06	#1/4-28 x 3/8 Pan Hd. Screw	1
35	69326	Bevel Scale	1
36	82418	#8-32 x 3/16 Set Screw	1
37	69277	Elevating Knob	1
38	305353	Washer	2
39	69291	Belleville Washer	1
40	54963	Bevel Knob	1
42	121477	King Bolt	1
43	99251-14	#5/16-18 x 7/8 Pan Hd. Screw	1
44	69273	Quadrant Handle	1
45	81787-01	Cable Clamp	1
46	80598	#8-32 x 3/8 Pan Hd. Self Tap Scr.	1
47	74991	Carriage Bracket	1
48	99270-06	10-32 x 3/8 Rd. Hd. Screw	4
49	417	Lockwasher	4
*50	91532-02	Lower Guard	1
*51	92084	Spacer	2
*52	99271-12	1/4-28 x 3/4 Pan Hd. Screw	1
53	46084	Washer	4
*54	37484	1/4-28 x 1/2 Pan Hd. Screw	1
*55	72718	Lock Nut	1
56	69286	Insert	1
*58	94459	Spring	1
*59	94462	Washer	1
60	81862	Grommet	1
61	84173	Lockwasher	1
		99389-06 (7710-02)	1
			2

BASE, TABLE & FRAME

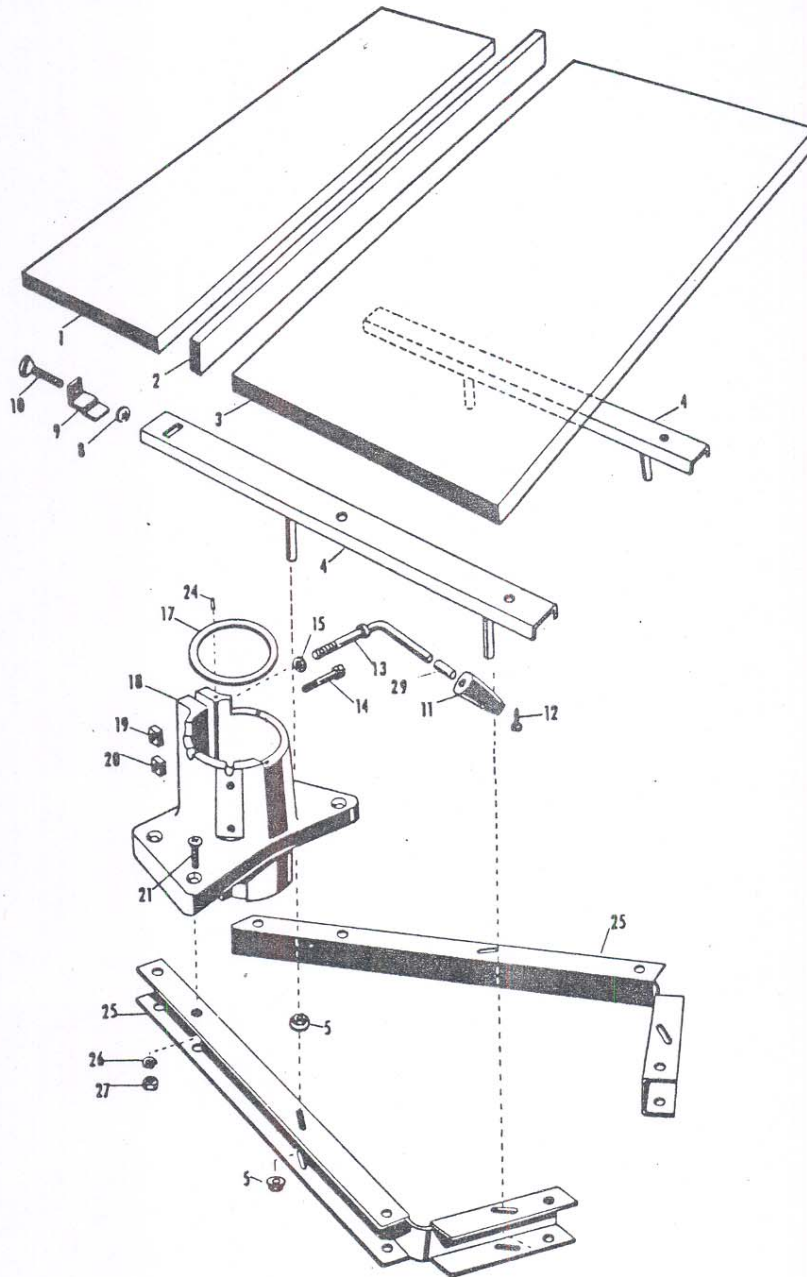

PARTS IDENTIFICATION

Index No.	Part No.	Description	Qty.	Index No.	Part No.	Description	Qty.
1	85754	Spacer Board	1	15	99358-09	Washer 80674	1
2	85756	Fence	1	17	69262	Base Washer	1
3	85755	Fixed Board	1	18	69258-01	Base 121732-01 (incl. #24)	1
4	121496-02	Cleat	2	19	80468	3/8-16 Square Nut	1
5	121582	5/16-18 Large Flange Hex Nut	8	20	99362-03	5/16-18 Square Nut	1
8	80050	Eyelet	2	21	84423	3/8-16 x 1-1/4 Flat Hd. Screw	4
9	72086	Cleat Bracket	2	22	121672	#10-32x3/4 Flat Hd. Screw 121732-01	2
10	80455	5/16-18 x 1-3/4 Thumb Screw	2	23	121656	Locating Ring 121732-01	1
11	70261	Clamp Handle (Inc. 29)	1	24	80585	Groove Pin 1/8x5/8	1
12	201287	1/4-14 x 5/8" PH Self Tapping Screws	4	25	69261-02	Channel 69261-03	2
13	72269	Base Clamp Handle	1	26	82510	3/8 Lock Washer 415	4
14	99171-28	5/16-18 x 1-3/4 Hex Hd. Screw	1	27	84180	3/8-16 Hex Nut	4
				29	69286	Insert	1

Cat. Nos. 7110/3410 Type I
 No. 710, 8" RADIAL ARM SAW
 Reliance on RARA

MOTOR

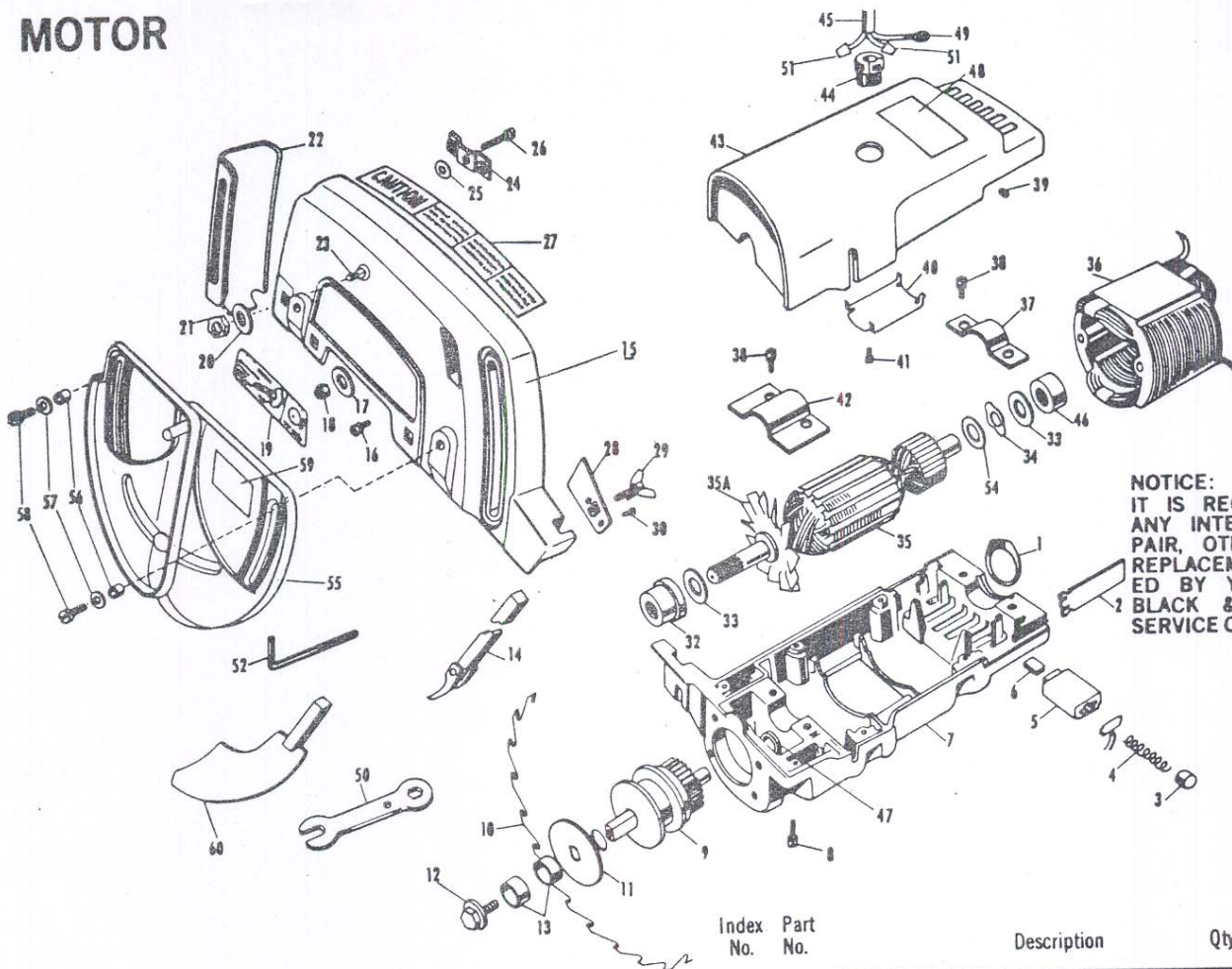

NOTICE:
IT IS RECOMMENDED THAT ANY INTERNAL MOTOR REPAIR, OTHER THAN BRUSH REPLACEMENT BE PERFORMED BY YOUR AUTHORIZED BLACK & DECKER/DeWALT SERVICE CENTER.

PARTS IDENTIFICATION

Index No.	Part No.	Description	Qty.
1	66815	Bearing Cover	1
2	66636	Brush Holder Cover	2
3	69991	Spring Cap	2
4	70077	Brush Spring	2
5	66635	Brush Holder	2
6	66678	Carbon Brush	2
7	66656-03	Lower Housing & Brg. (Incl. Item #47)	1
8	99452-12	#8-32 x 3/4 Fil. Hd. Screw	6
9	69400-01	Spindle, Brg. & Gear	1
10	35025	Saw Blade Comb. 8"	1
11	87093	Clamp Washer	1
12	69304	Arbor Screw	1
13	85809	Spacer	2
14	85019-01	Kickback & Fingers (7710, 7710-01)	1
15	85020-02	Guard & Labels (Includes Items 19 & 27)	1
16	99318-08	#8-32 x 1/2 Pan Hd. Scr & Lock Washer	4
17	82481	Washer	1
18	81966	Lock Nut	1
19	96685	Guard Nameplate 121777	1
20	46084	Washer	1
21	99374-05	Hex Nut	1
22	85018-01	Hold Down Bracket (7710, 7710-01)	1
	121601	Hold Down Bracket (7710-02)	1
23	38910	#1/4-20 x 1/2" Carriage Bolt	1
24	69283	Mounting Plate	1
25	37352-01	Washer	1
26	99170-16	1/4x1 Hex Hd. Scr.	1
27	96684	Caution Label 80126	1
28	69282	Retainer Plate Assy.	1
29	36382	#10-32x15/16 Wing Screw	1

Index No.	Part No.	Description	Qty.
30	80598	#8-32 x 3/8 Pan Hd. Self Tap Scr.	2
32	66818	Needle Bearing	1
33	54818	Fiber Washer	2
34	54831	Curved Washer	1
35	69338-31	Armature & Fan (120 Volt)(7710)	1
	69338-35	Armature & Fan (220 Volt)(7710-01)	1
	69338-37	Armature & Fan (240 Volt)(7710-02)	1
35A	69339	Fan	1
36	*121456-71	Field (120 Volt)(7710)	1
	*121456-75	Field (220 Volt)(7710-01)	1
	*121456-77	Field (240 Volt)(7710-02)	1
37	66680	Bearing Clamp	1
38	99460-07	#10-32 x 7/16 Fil. Hd. Screw	4
39	55050	Rubber Plug	2
40	65922	Field Spring	1
41	52819	#8-32 x 3/8 Thd. Form Scr. & Washer	1
42	66679	Bearing Clamp	1
43	70260	Upper Housing & Nameplate 69297-01 (Incl. Item #48)	1
44	33305	Heyco Bushing 445467	1
45	121457-01	Motor Cable (Incl. Item #49 & 51)	1
46	66817	Needle Bearing	1
47	66657	Sleeve Bearing	1
48	85026	Nameplate	1
49	34289	Lead Terminal	1
50	69412	Wrench	1
51	121462	Tapered Terminal Pins	2
52	99056-04	Allen Wrench	1
54	86469	Phenolic Washer	1
55	91531-03	Lower Guard (Incl. Item #59) 91531-04	1
56	92083	Spacer	2
57	745	Washer	2
58	121497	10-32 x 3/4 Pan Hd. Self-Tap Screw	2
59	121593	Caution Label	1
60	121586	Riving Knife (7710-02 only)	1

* Plus 1 (71025 - Strap)
1 (121458 (2) lead)
1 (121459 - wst. Sheet)

418622

Cat. Nos. 7710/3410 Type 1
No. 710, 8" RADIAL ARM SAW
Revision 10 8934

PARTS NOT SHOWN:
121461

Connection Diagram
Note: Grease can be obtained from B&D Service Centers.



BLACK & DECKER™

BLACK AND DECKER COMPANY-OWNED SERVICE CENTERS

	Area Telephone Code	Area Telephone No.	Area Telephone Code	Area Telephone No.
ALABAMA: Birmingham 35209, 2412 Green Springs Hwy	205	942-0538		
Mobile 36608, 3831 Airport Blvd.	205	343-8624		
ALASKA: Anchorage 99502, 907 East Dowling Road No. 10	907	563-4864		
ARIZONA: Phoenix 85013, 4501 N. 7th Ave.	602	279-8414		
ARKANSAS: Little Rock 72201, 519 W. Seventh St.	501	372-3040		
CALIFORNIA: Anaheim 92802, 1235 S. Euclid Ave.	714	772-4050		
Fresno 93710, 5412 North Blackstone Ave.	209	435-0810		
Long Beach 90805, 2011 South St.	213	422-5825		
Los Angeles 90007, 2432 S. Broadway	213	749-0371		
Riverside 92506, 4010 Merrill Ave.	714	787-9700		
Sacramento 95825, 2033 Fulton Avenue	916	972-9090		
San Diego 92111, 4927 Convoy St.	619	279-2011		
San Jose 95128, 1185 So. Bascom Ave.	408	293-7350		
So. San Francisco 94080, 1139 Airport Blvd.	415	871-7278		
San Leandro 94578, 15206 E. 14th St.	415	276-1610		
Van Nuys 91411, 14924 Victory Blvd.	818	787-5531		
COLORADO: Denver 80219, 1171 S. Federal Blvd.	303	922-8325		
CONNECTICUT: Orange 06477, 481 Boston Post Rd.	203	795-3583		
Hartford 06109, 682 Sias Deane Highway	203	583-5800		
DISTRICT OF COLUMBIA: Washington				
Bladensburg, MD 20710, 4501 Baltimore Ave.	301	779-3808		
Falls Church, VA 22046, 344 W. Broad St.	703	533-7313		
FLORIDA: Ft. Lauderdale 33334, 799 E. Oakland Pk. Blvd.	305	566-5102		
Jacksonville 32205, 920 Cassat Ave.	904	781-2253		
Miami 33168, 13345 N. W. Seventh Ave.	305	681-6658		
Oriando 32803, 3807 E. Colonial Drive	305	894-7011		
St. Petersburg (Pinellas Park) 33565, 7211 U.S. Highway 19, North	813	525-0273		
Tampa 33609, 3432 W. Kennedy Blvd.	813	872-8317		
West Palm Beach 33408, 4845 Gun Club Rd.	305	689-3247		
GEORGIA: Stone Mountain 30083, 5723 Memorial Drive	404	292-4714		
HAWAII: Honolulu 96813, 875 Auahi St.	808	536-9374		
ILLINOIS: Chicago 60646, Lincolnwood, 6710 N. Crawford Ave.	312	673-0923		
Chicago 60453, Oak Lawn, 6343 W. 95th St.	312	423-7212		
Des Plaines 60018, 1277 South Elmhurst Road	312	384-5220		
Moline 61285, 4433 23rd Ave.	309	782-3000		
INDIANA: Evansville 47710, 307 First Ave., Crescent Ctr.	812	425-4269		
Hammond 46323, 7103 Kennedy Ave.	219	845-5100		
Indianapolis (SPEEDWAY) 46224, 5999 Crawfordville Road	317	243-8308		
IOWA: Des Moines 50312, 2811 Ingersoll Ave.	515	244-7257		
KANSAS: Wichita 67213, 155 S. West St.	316	943-1271		
KENTUCKY: Louisville 40215, 5211 Preston Highway	502	988-7100		
LOUISIANA: Baton Rouge 70815, 11859 Florida Blvd.	504	272-8111		
Metairie (New Orleans) 70002, 3504 N. Causeway Blvd.	504	837-2550		
Shreveport 71108, 7710-7714 Jewella Road	318	688-1553		
MARYLAND: Baltimore 21211, 203 W. 28th St.	301	467-7411		
Baltimore 21205, 4712 Erdman Ave.	301	485-5550		
Baltimore North 21030, 29-31 Cranbrook Road, Cockeysville	301	866-5966		
Bladensburg (Wash., DC) 20710, 4501 Baltimore Ave.	301	779-3808		
MASSACHUSETTS: Boston (Brighton) 02135, 12 Market St.	617	782-8284		
MICHIGAN: Detroit 48219, 18133 W. McNichols Road	313	534-8880		
Grand Rapids 49508, 3040 28th St., S.E.	616	949-8331		
Warren 48093, 27035 Van Dyke Blvd.	313	756-8711		
MINNESOTA: Bloomington (Minneapolis-St. Paul) 55420, 9712 Garfield Ave.	612	884-9191		
MISSOURI: Kansas City 64111, 4324 Main St.	816	531-0629		
St. Ann 63074, 10933 St. Charles Rock Road	314	739-4881		
St. Louis 63131, 12852 Manchester Road	314	821-8740		
NEBRASKA: Omaha 68127, 4225 S. 84th St.	402	592-5666		
NEW JERSEY: Cherry Hill 08034, 1444 E. Marlton Pike	609	429-2822		
Paterson (Little Falls) 07424, RT 46 E. at Lower Notch Rd.	201	256-9373		
Union 07083, 2305 U.S. Highway 22 West (1 Block West of Flagship)	201	964-7040		
NEW MEXICO: Albuquerque 87107, 2812 Candelaria Rd., N. E.	505	884-1002		
NEW YORK: Albany (Latham) 12110, 836 Troy-Schenectady Rd.	518	785-1867		
Buffalo 14209, 881 W. Delavan Ave.	716	884-8220		
New York 11590, 1081 Old Country Rd. (Westbury, L. I.)	516	997-6140		
New York 10010, 50 West 23rd St. (Manhattan)	212	929-6450		
New York 11377, 56-15 Queens Blvd. (Woodside)	718	335-1042		
New York 10710, 2347 Central Park Ave. (Yonkers)	914	779-3810		
Rochester 14623, 2969 W. Henrietta Rd.	716	424-1310		
Syracuse 13214, 3485 Erie Blvd., East	315	448-3088		
NORTH CAROLINA: Charlotte 28205, 3007 E. Independence Blvd.	704	374-1779		
Greensboro 27407, 3718 High Point Road	919	852-1300		
Raleigh 27604, 2930 North Blvd.	919	878-0357		
OHIO: Cincinnati 45241, 2310 E. Sharon Road	513	772-3111		
Parma Heights (Cleveland) 44130, 6483 Pearl Road	216	842-9100		
Columbus 43227, 3975 E. Livingston Ave.	614	237-0461		
Dayton 45409, 2898 S. Dixie Drive	513	298-1951		
Toledo 43607, 3231 Dorr St.	419	531-8921		
OKLAHOMA: Oklahoma City 73108, 1318 Linwood Blvd.	405	232-7515		
Tulsa 74145, 3120 S. Sheridan Road	918	822-5686		
OREGON: Portland 97209, 1640 N. W. Johnson St.	503	228-8831		
PENNSYLVANIA: Allentown (Whitehall) 18052, 2242 MacArthur Rd.	215	435-9544		
Harrisburg 17112, 6070 Allentown Blvd.	717	545-0651		
Lancaster 17601, 118 Keller Avenue	717	393-5251		
Philadelphia 19103, 333 N. 20th St.	215	584-5520		
Pittsburgh 15232, 5437 Baum Blvd.	412	382-2700		
RHODE ISLAND: E. Providence 02914, 2777 Pawtucket Ave.	401	434-1655		
PUERTO RICO: Puerto Nuevo	809	783-3535		
SOUTH CAROLINA: Greenville 29607, 1557 Laurens Road	803	232-3038		
TENNESSEE: Knoxville 37917, 4110 N. Broadway	615	688-0921		
Memphis 38118, 1085 East Brooks Road	901	332-3444		
Nashville 37211, 4811 Nolensville Road	615	833-8277		
TEXAS: Amarillo 79108, 3008 West 8th Ave.	806	373-1531		
Austin 78757, 8549 Burnet Rd.	512	459-1133		
Dallas 75229, 2257 Royal Lane	214	820-8655		
El Paso 79925, 6822 Gateway East	915	778-9789		
Fort Worth 76111, 721 North Beach St.	817	831-3828		
Houston 77022, 536 E. Tidwell Road	713	692-7111		
Houston (S.W.) 77025, 9319 Stella Link Blvd.	713	664-3866		
San Antonio 78201, 500 Culebra Ave.	512	732-1221		
UTAH: Salt Lake City 84115, 1541 S. Third West St.	801	488-5828		
VIRGINIA: Falls Church 22046, 344 W. Broad St.	703	533-7313		
Norfolk 23513, 7831 Sewalls Point Road	804	480-3333		
Richmond 23222, 1424 Chamberlayne Ave.	804	849-9245		
WASHINGTON: Seattle 98109, 701 Third Ave., North	206	282-6432		
Spokane 99208, N. 7011 Division Street	509	467-8190		
Tacoma 98409, 2802 S. 38th St.	206	473-8040		
WEST VIRGINIA: Charleston 25312, 1838 Sixth Ave.	304	343-0289		
WISCONSIN: Milwaukee (West Allis) 53227, 10903 W. Lincoln Ave.	414	543-9590		