

CRAFTSMAN

ACCESSORIES

FOR WOOD LATHES

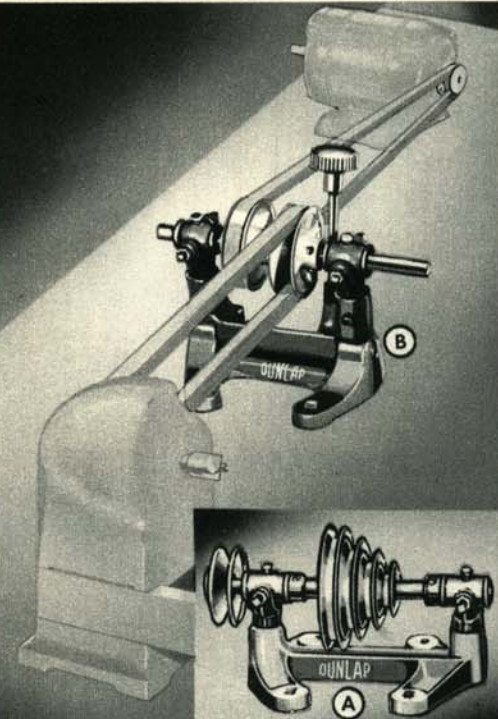

Jack Shafts for Speed Variations

For providing broad speed range on lathes, drill presses, jig saws, sanders, grinders, buffers, etc. Generally used between motor and tool being driven. By selection of proper pulleys, speed of the jack shaft itself may be raised or lowered from motor speed. This raises or lowers the entire range of speeds on the driven machine. In this way much lower and much higher speeds are obtainable than are practical with direct drive. Both types have self-aligning, auto-lubricating bronze bearings with oil reservoirs around bearings.

- (A) Cone Pulley Jack Shaft.** Varies the speed in certain definite steps. Used with matching cone pulley on machine. For use with 1/2-in. "V" belt. Shpg. wt., 7 lbs. 8 oz.
9 PT 2494—Be sure to state size.
 With 3-inch, 3-step pulley..... **\$2.95**
 With 4-inch, 4-step pulley..... **\$3.10**
 With 5-inch, 4-step pulley..... **3.25**

- (B) Multi-Speed Jack Shaft.** The ideal type of speed variation—does away with a series of steps and permits a gradual increase or decrease in the R.P.M. of the driven tool. Makes possible an infinite number of speeds with a 3 to 1 range between low and high speeds. Speeds of 1000 to 3000 R.P.M. obtainable where a 1750 R.P.M. motor is used without changing belts, pulley or stopping motor. Positive drive assured at all times.
9 PT 2496—Shpg. wt., 6 lbs..... \$4.25

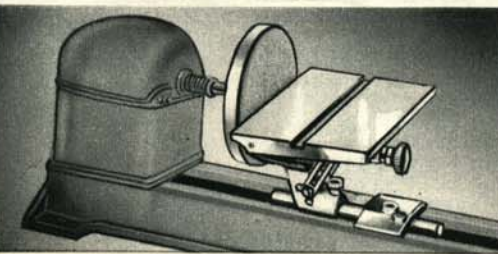

Sanding Attachment

For perfect sanding jobs. Rugged table is firmly mounted on lathe bed. May easily be tilted to any angle. Sanding disc not included (see below). Shipping weight, each, 9 pounds.

Catalog No.	For Lathe	Price
9 PT 2250	99 PTM 2019 on P. 22	\$3.35
9 PT 2096	99 PTM 2027 on P. 23	3.35

8-inch Sanding Discs. Threaded to fit lathe spindles. Shipping weight, each, 2 pounds.

Catalog No.	For Lathe	Price
9 PT 2160	99 PTM 2019 on P. 22	\$2.35
9 PT 2162	99 PTM 2027 on P. 23	2.35



BALANCED TURNING CHISELS

Good work demands good tools! These chisels have brightly polished 4-inch blades of carefully tempered tool steel. Expertly ground. Keep a biting keen edge for fast, clean cutting. 8-inch handles, beautifully finished. Heavy ferrule. Average length over all, 13 inches. Genuine CRAFTSMAN quality at moderate prices. Shipping weight, each, 13 ounces.

- (A) 9 PT 2850—Gouge, 1/4-inch wide..... **69c**
 (B) 9 PT 2851—Gouge, 1/2-inch wide..... **69c**
 (C) 9 PT 2852—Gouge, 3/4-inch wide..... **98c**
 (D) 9 PT 2856—Round Nose Chisel, 1/4-inch wide **69c**
 (E) 9 PT 2858—Parting Tool, 1/4-inch wide..... **69c**
 (F) 9 PT 2862—Skew Chisel, 1/4-inch wide..... **69c**
 (G) 9 PT 2863—Skew Chisel, 1-inch wide..... **98c**
 (H) 9 PT 2854—Spear Point Chisel, 1/2-in. wide. **69c**

9 PT 2853—Complete set of 8 chisels listed above, in sturdy box. Shipping weight, 8 lbs. 10 oz..... \$7.65

PROFESSIONAL TURNING CHISELS

We believe this new line of wood-turning chisels is the finest that can be bought anywhere! Average over-all length, 16 3/4 in. Forged tapered blades, extra hard; made of high-carbon steel with vanadium added to give toughness. Blades are highly polished and chrome-plated. Maple handles with beautiful natural finish. Shipping weight, each, 1 pound 2 ounces.

- (A) 9 PT 2877—Gouge, 1/4-inch wide..... **\$1.59**
 (B) 9 PT 2878—Gouge, 1/2-inch wide..... **\$1.69**
 (C) 9 PT 2879—Gouge, 3/4-inch wide..... **1.69**
 (D) 9 PT 2891—Round Nose Chisel, 1/4-inch wide. **1.15**
 (E) 9 PT 2893—Parting Tool, 1/4-inch wide.... **1.29**
 (F) 9 PT 2894—Skew Chisel, 1/4-inch wide.... **1.15**
 (G) 9 PT 2895—Skew Chisel, 1-inch wide..... **1.29**
 (H) 9 PT 2890—Spear Point Chisel, 1/2-inch wide. **1.15**

9 PT 2898—Set of 8 professional chisels listed above, in heavy box. Shipping weight, 11 lbs..... \$10.95

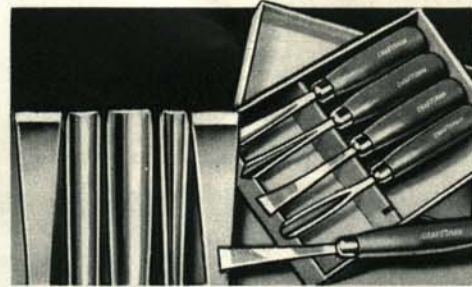

CRAFTSMAN Wood-Carving Tools

Finely finished wood-carving tools. 2 1/4-inch blades forged from fine quality heat-treated steel; take and hold a razor-keen edge. 3 3/4-inch handles, well polished and finished. With these tools you can make a great variety of wood carvings. Great favorites with wood carvers who take pride in their work.

- Complete set of 5 tools attractively boxed; includes one each of the following: 3/8-inch bent gouge, 1/4-inch bent chisel, 1/2-inch U tool, 1/4-inch straight chisel and a 1/2-inch veining tool. Shipping weight, 13 oz.
9 PT 2899—Set of 5..... \$2.35
9 PT 2464—Set of 3 tools including a 1/2-inch U tool, 1/4-inch skew bevel, and 1/2-inch bent chisel. Packed in a box. Shipping weight, 8 ounces..... \$1.59



Tool-Room Necessities

- (A) CRAFTSMAN Sharpening Stone.** Vitrified silicon carbide. One side medium for fast cutting, other side fine for smooth edge. Size, 7x2x1 inch.
9 PT 6440—Shipping weight, 1 pound 8 ounces. \$1.25
(B) DUNLAP Slip Stone. Medium-fine. For gouges and other round-shaped tools
9 PT 6454—Shipping weight, 12 ounces..... 45c
(C) Ball Bearing Lubricant. For power tools.
28 PT 4432—4-oz. tube. Shpg. wt., 11 oz..... 15c
(D) DUNLAP Stop Rust. Protects tools from rust. Not a lubricant.
9 PT 2927—Shpg. wt., 8 oz..... 29c
(E) Handy Tool Clips. Steel, adjustable tension.
9 PT 2865—5 mounted clips. Shpg. wt., 10 oz. 25c

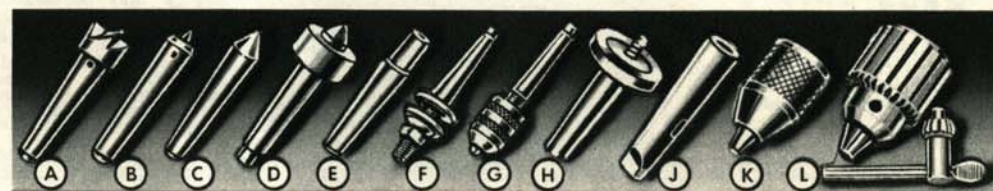

High Quality Lathe Centers and Arbors

No. 2 Morse taper shanks. Accurately ground for perfect fit. Tapered portion of shank is 3 in. long. Check you spindle before ordering.

- (A) 9 PT 2107—Spur Center. Shpg. wt., 7 oz..... **69c**
 (B) 9 PT 2101—Cup Center. Shpg. wt., 7 oz..... **69c**
 (C) 9 PT 2111—60-Degree Center. Shpg. wt., 7 oz. **65c**
 (D) 9 PT 2113—Precision Ball Bearing 60-Degree Center. Shipping weight, 8 ounces..... **\$2.25**
 (E) 9 PT 2124—Arbor for Jacobs' chuck. Shipping weight, 7 ounces..... **75c**
 (F) 9 PT 2163—Arbor for grinding, etc. Shipping weight, 13 ounces..... **89c**
 (G) 9 PT 2125—Arbor and 1/2-inch Chuck. Shipping weight, 1 pound 8 ounces..... **\$1.29**
 (H) 9 PT 2115—Screw Center. Shpg. wt., 14 oz..... **1.15**
 (J) 9 PT 2161—Adapter Sleeve. To change from No. 2 to No. 1 Morse taper arbor. Shpg. wt., 5 oz..... **59c**

No. 1 Morse taper. Accurately ground and finished. Tapered part of shank is 2 3/4 inches long. Check your spindle before ordering. Shipping weight, each, 8 ounces.

- (A) 9 PT 2106—Spur Center. **65c**
 (B) 9 PT 2100—Cup Center.. **65c**
 (C) 9 PT 2110—60-Degree Center..... **65c**
 (D) 9 PT 2112—Precision 60-Degree Ball Bearing Center **\$2.10**
 (E) 9 PT 2123—Arbor for Jacobs' chuck..... **65c**
 (F) 9PT2165—Grinding Arbor. **85c**
 (H) 9 PT 2116—Screw Center **1.15**
 (K) 9 PT 2132—1/2-inch Chuck.
 For 9 PT 2166 grinding arbor **65c**

Jacobs' Chuck

(L) Extremely high quality throughout. Cannot be used on threaded spindles. Fits modified No. 2 Morse taper. Used with 9 PT 2123 arbor for lathe on Page 22, or 9 PT 2124 arbor for lathe on Page 23. Shpg. wt., 2 lbs.

- 9 PT 2142—Capacity, 1/4 to 1/2-inch..... \$5.65**
9 PT 2143 Capacity, 0 to 1/4-inch... \$6.65

DUNLAP WOOD TURNING LATHE



\$5.95

99 PT 02051

NOTICE THE SIZE! A FULL 38-INCH BED!

- Double bearing, heavily built, vibrationless headstock—enclosed for safety.
- Two high quality auto-lubricating bronze bearings for extra long life.
- 8-inch swing—27-in. between centers—full 38-in. bed—3 speeds.

Never before a lathe of this quality and capacity at anywhere near this price. Same type enclosed headstock as on our higher priced models. Will handle work up to 27 in. between centers—up to 8 in. in diameter. All parts carefully machined and fitted. Bronze bearings assure smooth vibrationless operation. Ball thrust bearing absorbs spindle thrust. $\frac{3}{8}$ -in. spindle projects for out-board turning. Complete with 6-in. tool rest, cup and spur centers. Use $\frac{1}{4}$ or $\frac{1}{2}$ -H.P. motor and 9 PT 2788 motor pulley listed on Page 45. Over all height, 9 $\frac{1}{4}$ in.; width, 4 $\frac{1}{2}$ in.; length, 40 in.

99 PT 02051—Shipping weight, 22 pounds . . . \$5.95

Lathe Grinding Attachment. Shown in left inset. Use it for all kinds of grinding. Includes guard, tool rest, arbor to fit on spindle, 4x $\frac{3}{4}$ -in. grinding wheel, clamps, etc., for use on above lathe. Shipping weight, 1 lb. 10 oz.

9 PT 2011 \$1.59

Lathe Sanding Attachment. Shown in right inset. Consists of tilting table made of ground gray iron and mountings for use on above lathe. To be used with sanding disc 9 PT 2158 listed below. Shipping weight, 6 lbs. 8 oz.

9 PT 2214 \$3.25

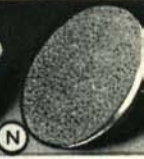
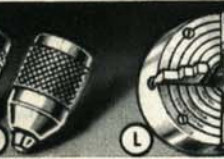
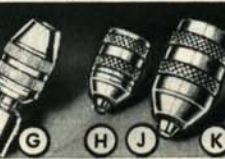
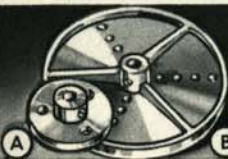

Face Plates

For number 99 PT 02051 or any other lathe with $\frac{1}{2}$ -in. plain spindles. Be sure to check spindle size before ordering.

- A 9 PT 2080—3 $\frac{1}{2}$ -in. Shipping weight, 7 ounces 89c
- B 9 PT 2081—6-in. Shipping weight, 14 ounces \$1.60

Spur Center

C For 99 PT 02051 or any other lathe with $\frac{3}{4}$ -in. spindles. Check spindle size. Shipping weight, 6 ounces.

- 9 PT 2105 65c

Cup Center

D Carefully made. For tallstock of lathe. Fits any $\frac{3}{8}$ -in. spindle. Check spindle size. Shipping weight, 6 ounces.

- 9 PT 2102 65c

Work Arbor with Chuck

E Fits $\frac{1}{2}$ or $\frac{3}{8}$ -in. straight spindle. Fastens on spindle with 2 set screws. $\frac{1}{4}$ -in. x 24-thread. 3-jaw $\frac{1}{2}$ -in. chuck. State whether for $\frac{1}{2}$ or $\frac{3}{8}$ -in. spindle. Check before ordering.

- 9 PT 2118—Shpg. wt., 1 lb. 10 oz. 98c

Work Arbor

F Same as 9 PT 2118, above, without chuck. Has finely faced steel collars to clamp grinding or buffing wheel. State whether for $\frac{1}{2}$ or $\frac{3}{8}$ -in. spindle. Check before ordering.

- 9 PT 2120—Shipping weight, 15 ounces 49c

$\frac{1}{2}$ -in. CRAFTSMAN Drill Chuck and Arbor

G 3-jaw ground chuck with adapter, for lathes or motors with $\frac{1}{2}$ -in. or $\frac{3}{8}$ -in. straight spindles. Arbor is $\frac{1}{2}$ -in. x 24-thread. State whether for $\frac{1}{2}$ or $\frac{3}{8}$ -in. spindle. Check before ordering.

- 9 PT 2140—Shpg. wt., 1 lb. 6 oz. 98c

3-Jaw Chucks

Accurately machined to run true. Nicely finished. Superior to ordinary chucks. Fit $\frac{1}{2}$ -inch 24-thread per inch spindles. Check before ordering.

- H 9 PT 2130— $\frac{1}{2}$ -inch capacity. Shipping weight, 5 ounces 29c
- I 9 PT 2132— $\frac{3}{4}$ -inch capacity. Shipping weight, 12 ounces 65c
- J 9 PT 2134— $\frac{1}{2}$ -inch capacity. Ground for accuracy. Shipping weight, 1 pound 89c

4-Jaw Independent Chuck

K 4-inch capacity; reversible jaws. Well made, nicely machined. Fits any lathe with $\frac{3}{4}$ -inch straight spindle. Be sure to check spindle size. Shipping weight, 3 lbs. 12 oz.

- 9 PT 2136 \$5.65

Drum Sander

L Accurately made. Complete with sleeve and adapter. Fits $\frac{1}{2}$ -in. x 24 threaded shaft. 3 in. long, 2 $\frac{1}{4}$ in. diam. To put on new sleeve, just loosen adapter nut. Shpg. wt., 12 oz.

- 9 PT 2520 98c

M 9 PT 2522—Sanding sleeve for above drum. Fine, medium or coarse. State grit wanted. Shpg. wt., 2 oz. Each. 10c

Sanding Discs

N Carefully machined and balanced aluminum discs fitted with sandpaper. Fit only $\frac{3}{4}$ -in. straight spindle. Be sure to check spindle size.

- 9 PT 2158—6-inch. Shipping weight, 12 ounces \$1.65
- 9 PT 2159—8-inch. Shipping weight, 1 pound \$1.95

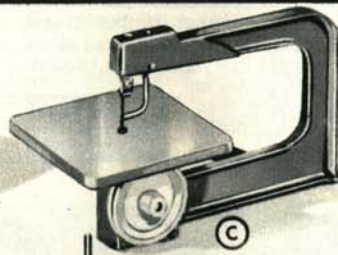
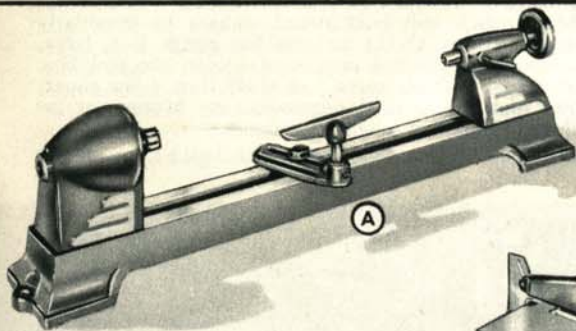

"JUNIOR" Wood Turning Lathe
\$3.35 A Here's a real workmanlike lathe with the features you want—at a moderate price. It's big—note these over-all dimensions: height, 6 $\frac{1}{4}$ in. width, 4 $\frac{1}{2}$ in.; length, 23 $\frac{1}{2}$ in. Handles work up to 5-in. diameter, 12 in. long. 2 speeds. Has enclosed headstock and spur and cup centers. Machined ways.
 9 PT 2911—Shipping weight, 12 pounds \$3.35

"JUNIOR" Bench Saw
\$3.85 B Now—a small bench saw with the adjustments and features of much larger machines. 7x9-in. ground iron table tilts to 45 degrees on double pivots. 4-inch blade adjusts to any depth of cut up to 1 inch. Rip fence and miter gauge; guard and splitter, all included as standard equipment. Over-all dimensions: height, 6 $\frac{1}{4}$ in.; width, 10 in.; depth, 10 $\frac{1}{4}$ in.
 9 PT 2910—Shipping weight, 9 lbs. 6 oz. \$3.85

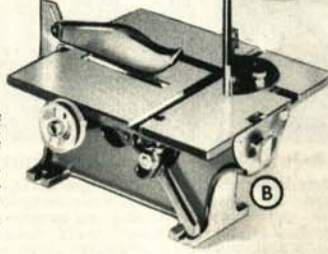

"JUNIOR" Jig Saw
\$2.50 C New—never before to our knowledge has there been a jig saw with an oil bath mechanism within 75% of our sensational low price! Full 10-inch throat. Sturdy gray iron frame. Table, 8x8 inches. New tension-type enclosed spring head. Shipping weight, 10 lbs.
 9 PT 2913 \$2.50

"JUNIOR" Motor
\$4.25 D Smooth running 3400 r.p.m. motor to keep your "JUNIOR" tools humming. A regular 110-volt, 60-cycle a.c. power plant. Built for steady service. Use drive belt 9 PT 2727 or 9 PT 2714 with this motor. Brass pulley. Cord and plug included. Shpg. wt., lbs. 6 oz.
 9 PT 2725 \$4.25

"JUNIOR" Drill Press
\$3.19 E A new idea in drill presses! $\frac{3}{8}$ -in. capacity. Drills to center of a 6-inch circle. 4x4-in. table and base are ground gray iron. Column is $\frac{3}{4}$ x10 $\frac{1}{2}$ inches. Over-all dimensions: height, 17 $\frac{3}{4}$ in.; width, 5 in.; depth, 10 $\frac{1}{4}$ in. Shpg. wt., 8 lbs. 6 oz.
 9 PT 2912 \$3.19



10c F Round rubber belt, $\frac{1}{2}$ x16 $\frac{1}{2}$ in. outside diameter, for use with "JUNIOR" motor 9 PT 2725 above. They are so inexpensive that it will pay to have one for each tool.
 9 PT 2727—Shipping weight, 2 ounces 10c
 A regular "V" belt built like our standard line, but light and flexible. For use with "JUNIOR" motor, 9 PT 2725.
 9 PT 2714— $\frac{1}{2}$ x32-inch "V" Belt. Shpg. wt., 3 oz. 29c

DUNLAP CONVERTIBLE LATHE

MAY BE USED FOR BOTH WOOD OR METAL TURNING



Face Plate Work Is Easy on This Lathe



Turning Table Legs Is Fascinating Work



Tool Rest Is Designed for Greater Rigidity



\$16⁹⁵

SPECIFICATIONS

Over-all Height	10 1/4 inches	
Over-all Width	7 inches	
Over-all Length	46 inches	
Swing Over Bed	9 inches	
Distance Between Centers	30 inches	
Spindle Bearings	2; oilite bronze	
Thrust Bearings	1; ball bearing	
Spindle	Nose Size	3/4 in.; 16 R.H. thread
	Taper Hole	8 3/4 in. x 3/4 inch No. 1 Morse 3/8 inch
Tailstock Taper	No. 1 Morse	
Speeds	4; 700, 1300, 2300, 4000 R.P.M.	
Motor Recommended	1/2-H.P., 1750 R.P.M. 99PT05620 or 99PT01955	
Machine Pulley Supplied	4-step cone	
Motor Pulley Recommended	99PT2792, 4-step cone	
Mounting Recommended	99PTM2786, metal lathe stand or 99PTM2721, work bench	
Mounting Dimension (Center to center of holes in base)	5 1/2 inches x 4 3/4 inches	

9-INCH SWING 44-INCH BED

- Bearings on both sides of spindle pulley for perfect spindle support
- Oversize bronze bearings are self lubricated. Sealed against dirt
- No. 1 Morse taper centers in head stock and tail stock
- 4 speeds from 700 to 4000 R.P.M.
- 30 inches between centers. Has full 9-inch swing over bed

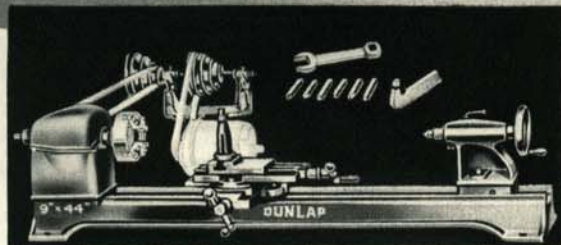

COMPLETE METAL WORKING OUTFIT

Build your metal working shop around this handy outfit! The sturdy construction of the lathe makes it suitable for adoption to metal work. Ideal size to handle armature turning and any light metal repair jobs you may wish to do. Easily changed over from metal to wood.

\$43⁵⁰

The multiple speed jack shaft provides the slow speeds and greater power necessary for smooth, clean cutting in metal. The compound rest adjusts from 0 to 180 degrees angular position. Longitudinal feed is 6 inches and cross feed 5 1/8 inches. The independent 4-jaw chuck will hold round, square or irregularly shaped pieces. Outfit includes our DUNLAP 9-in. lathe, compound rest, tool post, tool holder, six tool bits, wrenches, multiple speed jack shaft, 4-in. 4-jaw chuck, belt, pulleys, and 60 degree-center. Motor not included. Shipping weight, 93 pounds.

99 PTM 2020—Complete Outfit with Lathe . . . \$43.50

Can't be matched elsewhere at anywhere near this price! Big enough for almost ANY job—and built heavy enough to do metal turning with proper attachments!

The double-bearing mounting of the spindle makes it easy to turn large diameter work on the outside end of the spindle. All bearings are auto lubricated bronze, sealed in a bath of oil. This close, tight seal keeps spindle journals accurate . . . dirt-free. All longitudinal thrust is absorbed by the built-in ball thrust bearing.

Husky 44-inch gray iron bed is built for smooth operation even under heavy cuts. Tail stock may be set over for turning tapers. Bed is so designed that compound rest may be used close to headstock and yet be perfectly supported. Indexed head stock pulley makes dividing and fluting easy. Head stock spindle has right hand threads inboard, left hand threads outboard permitting use of face plates on either end without reversing motor. With "V" belt, wrench, 8-in. tool rest, and No. 1 Morse taper spur and cup centers. Shpg. wt., 60 lbs.

99 PTM 2019—DUNLAP Lathe . . . \$16.95

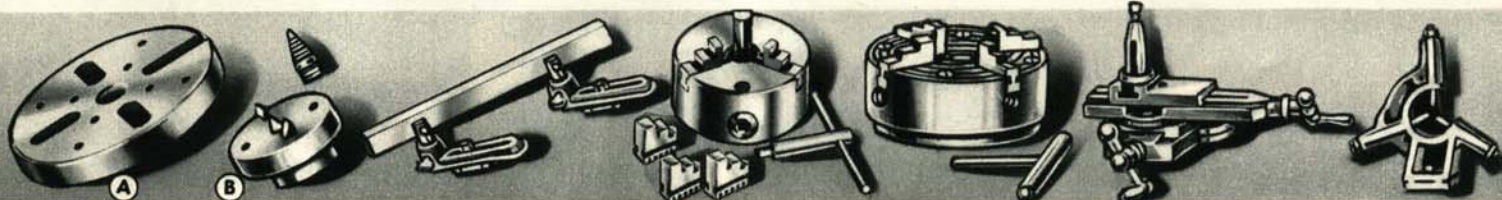

High Grade Face Plates

- Ⓐ 9 PT 2088—5 1/4-inch. Right hand thread for inboard turning. Fits 3/4-in. threaded spindle. For 99 PTM 2019 lathe above. Shipping weight, 3 lbs. 8 oz. . . . \$1.49
- 9 PT 2089—5 1/4-inch. Left hand thread for outboard turning. Fits 3/4-inch threaded spindle. For 99 PTM 2019 lathe above. Shipping weight, 3 lbs. 8 oz. . . . \$1.49
- Ⓑ 9 PT 2091—3-inch. Complete with spurs, removable center, and screw center. Fits 3/4-inch right hand threaded spindle. For lathe 99 PTM 2019 shown above. Shipping weight, 1 pound 12 ounces. . . . \$1.20

18-in. Tool Rest

A great convenience when making long turnings, such as table legs or lamp spindles. Readily adjusted for height. Well machined and nicely finished. Complete with bed brackets. Shpg. wt., 7 lbs.

99 PT 2173 . . . \$2.65

3-Jaw Chuck

3-inch diameter; grips round or hexagonal work. All jaws move at once. 2 sets of jaws (inside and outside). Fits 3/4-inch threaded spindle. For lathe 99 PTM 2019, above. Shipping weight, 3 lbs. 8 oz.

99PT2152 . . . \$14.45

4-Jaw Chuck

Four husky jaws, each one reversible, and can be moved by itself. 4-inch diameter. Key and back plate to fit 99 PTM 2019. Fits 3/4-in. threaded spindle. Shpg. wt., 4 lbs. 4 oz.

99PT2156 . . . \$5.65

Compound Rest

Feed collars graduated to 1/1000 inch. Angular dial graduated to 180 degrees. Transverse feed, 5 1/8-in.; angular or longitudinal feed, 6-in. Precision built. (For tool bits and holders, see Page 27.) Shpg. wt., 17 lbs.

99PT02168 . . . \$15.45

Steady Rest

For supporting extra long work in lathe. Fitted with best quality brass jaws! Very essential when turning long, slender pieces in the lathe. Shipping weight, 4 pounds.

99PT2178 . . . \$4.50

SEE PAGE 20 FOR ADDITIONAL LATHE ACCESSORIES

CRAFTSMAN BALL BEARING LATHE

PRODUCTION TYPE! FOR WOOD OR METAL TURNING!

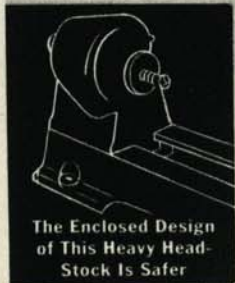

The Enclosed Design of This Heavy Head-Stock Is Safer

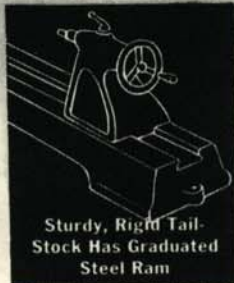

Sturdy, Right Tail-Stock Has Graduated Steel Ram

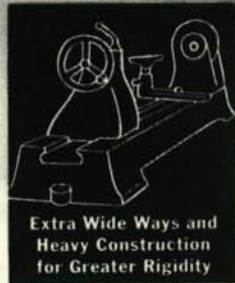

Extra Wide Ways and Heavy Construction for Greater Rigidity

\$329⁹⁵

10-INCH SWING . . 36-INCH BETWEEN CENTERS . . 54-INCH BED

- Heavy gray iron flat-way bed with 1½-inch ways. Total bearing surface 3 inches!
- Two heavy duty sealed precision ball bearings in headstock for smooth accurate operation
- No. 2 Morse taper centers in both headstock and tailstock
- Great weight makes it readily adaptable for metal turning with proper attachments

This **CRAFTSMAN** production-type lathe is the perfect tool for the master craftsman. Because of its excellence in every detail of construction, it has gained an important place in professional woodworking and pattern shops all over the country. It's built for professional use! That's why it is so popular with both professional and amateurs all over the country.

Check the features . . . the specifications . . . the modern design . . . the weight! See for yourself how far superior this lathe is to *any* you have ever seen in this price range! It has a massive flat-way bed that actually has a total bearing surface of 3 full inches! This allows you to take the heaviest cuts easily. The ways continue right up to the headstock so as to provide perfect mounting for compound rest or tool rest close to the headstock. The great weight of the entire lathe insures smooth, vibrationless, accurate operation.

The headstock spindle rotates on precision ball

bearings, sealed against dirt and abrasive materials. It has a right hand thread inboard and a left hand thread outboard to allow you to do outboard turning on large pieces without reversing motor or lathe drive. Longitudinal thrust is absorbed by ball bearing. Headstock pulley is indexed so work may be evenly divided or fluted. Headstock pulley and belt are covered to give you additional protection.

The tailstock is fitted with accurately ground steel ram and an automatic knock-out device for easily removing the No. 2 Morse taper centers and arbors. Ram is graduated in 1/16-inch divisions. The headstock and tailstock are fitted with No. 2 Morse taper sockets for removable centers and arbors.

Complete with 4-step motor pulley, V-belt, wrench, cup and spur centers, and tool rest. Shipping weight, 115 lbs.

99 PTM 2027 \$32.95



SPECIFICATIONS

Over-all Height	13½ in.	
Over-all Width	8½ in.	
Over-all Length	56½ in.	
Swing Over Bed	10 in.	
Dist. Between Centers	36 in.	
Spindle Bearings	2 precision ball bearings	
Thrust Bearings	Thrust taken on main bearings	
Spindle	Nose Size Taper Hole 1 in., 8 thread, R. H. 9/16 x 1 1/8 in. No. 2 Morse 5/8 in.	
Tailstock Taper		No. 2 Morse
Speeds		4,700, 1300, 2300, 4300 R.P.M.
Motor Recommended	1/4 or 1/2-H.P.; 1750 R.P.M. Condenser type	
Machine Pulley Supplied	5-in., 4-step cone	
Motor Pulley Supplied	5-in., 4-step cone	
Recommended Mountings	99 PTM 2787 stand or 99PTM2721 work bench.	
Mounting Dimension (Center to center of holes in base)	7½ x 5 1/4 in.	

REPAIR PARTS

Should you ever need repair parts for any of Sears power tools, you can always get them quickly and easily because every part is conveniently numbered. See inside front cover for complete details.



Lathe Bed Extension

A handy accessory for extra long work. 15 inches long. Accurately machined. Rigid construction. Shipping weight, 14 lbs.
 9 PT 2017—For Lathe 99PTM2019, on opposite page . . . \$2.75
 9 PT 2029—For Lathe 99PTM2027, listed above \$4.25

4-Jaw Chuck

4-inch diameter. Four reversible jaws move independently of each other. Back plate fits 1-in., 8-thread spindle as on 99 PTM 2027 lathe, above. Shipping weight, 4 lbs. 2 oz.
 9 PT 2138. \$5.65

3-Jaw Chuck

Four-inch diameter universal chuck. Accurate self centering, heat-treated jaws. Fits 1-in., 8-thread spindle as on 99 PTM 2027 lathe, above. Shipping weight, 4 lbs. 8 oz.
 9PT2148. \$14.95

Steady Rest

For supporting long work in lathe and preventing vibration in long, slender pieces. Clamps to lathe bed. Fitted with adjustable brass jaws. Shipping weight, 5 lbs. 8 oz.
 9 PT 2023 \$4.95

Compound Rest

Fits 99PTM2027 lathe. Dial graduated to 180 degrees; swivels through 360 degrees. Transverse feed, 6 1/8 inches; longitudinal feed, 7 1/2 inches. Precision built. Without tool holder; see Page 27. Shipping wt., 29 lbs.
 99 PT 02094 \$17.50

24-In. Tool Rest

For 99 PTM 2027 lathe, listed above. Useful when turning long pieces such as table legs, lamp standards, etc. Rigid construction. Complete with bed brackets. Shipping wt., 10 lbs.
 9PT2095. \$3.65

Face Plates

Fit 1-in. 8-thread spindle on 99 PTM 2027.
 A 9 PT 2085—3 1/2 in. (inboard). Shpg. wt., 2 lbs. \$1.45
 B 9 PT 2092—9 in. R.H. thread (inboard). Shpg. wt., 6 lbs. 10 oz. \$3.19
 9 PT 2093—9 in. Left hand thread (outboard). Shipping wt., 6 lbs. 10 oz. . . . \$3.19
POWER TOOL . . . 23

SEE PAGE 20 FOR CHISELS, ACCESSORIES, CENTERS, ETC.

NEW DUNLAP METAL-TURNING LATHES



\$16⁹⁵

99 PT 02053

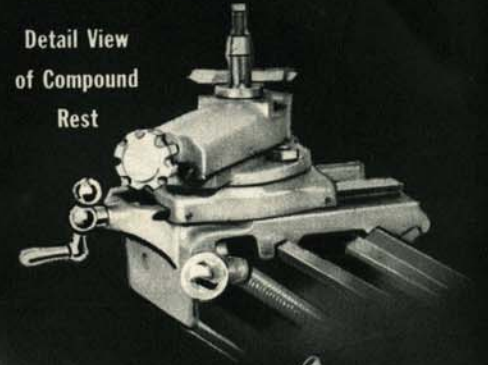

Detail View
of Compound
Rest



\$29⁹⁵

99 PT 02062

**NEW!
OFFSET CENTER
DESIGN . . ASSURES
MUCH SMOOTHER
OPERATION**

SPECIFICATIONS

For Both Lathes On This Page	
Over-all Height	9 1/2 in.
Over-all Width	8 3/4 in.
Over-all Length	31 in.
Length	32 in.
Swing Over Bed	6 in.
Swing Over Carriage	2 1/4 in.
Capacity Between Centers	18 in.
Spindle Bearings	No. 2 Bronze
Spindle	Size
	Nose Taper Hole
Spindle	4; 580-2040
Speeds	8; 116-2040
Lead Screw	Size
	Thread
Tailstock Ram Travel	1 1/4 in.
Tailstock Set Over	3/8 in.
Compound Rest Travel	1 3/4 in.
Cross Slide Travel	2 3/4 in.
Centers	Angle
	Fit
Motor Recommended	1/4 or 1/2-H.P.
Recommended Mounting	99PTM2721 Work Bench
Mounting Dimensions	5x24 3/8 in.
For Lathes 99PT02062 Only	
Back Gear	No. 4
Bearings	Bronze
Back Gear Ratio	5 to 1
Feeds	.0024; .0039
	.0048; .0078
Thread Range	8 to 96
	R.H. or L.H.

NO OTHER LATHES IN THE WORLD LIKE THESE!

- Accurately machined V-way bed . . . 6-inch swing . . . full 18 inches between centers.
- Double-bearing headstock has finest bronze bearings; front bearing fully adjustable.
- This lathe is equipped with removable No. 0 Morse taper centers in headstock and tailstock.
- Has an accurate compound rest, with adjustable gibs and lock (see small view above).

Here, at last, is a well-made, accurate metal turning lathe at a price that places it within the reach of the average craftsman! Never before, in the history of power tools, has there been a lathe anything like it! You can pay three times as much—and still not match it!

It's not just a small carbon copy of larger metal lathes—but an entirely new tool designed to have the stability and many advantages of larger machines! For example, the new offset-center construction permits exceptionally smooth and accurate operation. It keeps the pressure of the work on the tool bit between the ways—even when handling larger work. In this way, this construction overcomes one of the great disadvantages of ordinary small metal turning lathes.

Its accuracy is entirely adequate for a large percentage of metal turning work. Ideal for armature turning and much small shop work. Notice the husky, fully enclosed streamlined headstock. Has bronze bearings on BOTH sides of spindle pulley. Has knock-out centers in headstock and tailstock. Tailstock may be set over for turning tapers. Cross feed and angular feed are gibbed for take up. Full length lead screw provided for longitudinal feed of carriage.

99 PT 02053—DUNLAP Metal Turning Lathe as shown above at left. Shpg. wt., 40 lbs. . . . **\$16.95**
9 PT 2084—4-step motor pulley for use with above lathe. Shipping weight, 1 lb. **59c**

DUNLAP Complete Metal Turning Lathe

Illustrated above at the right of this page. This lathe is the same as 99 PT 02053 described directly above, but it comes complete with back gears, threading gears, gear cover and threading dial—perfectly installed at the factory.

The back gears and threading gears are of great assistance in getting the most out of your lathe. Metal turning speeds are always much slower

than wood turning speeds. The back gears give this slower speed and much greater power—both very desirable for efficient metal turning. The threading gears permit cutting threads from 8 to 96 threads per inch. Complete as shown above at right. Shipping weight, 56 pounds.

99 PT 02062—DUNLAP Complete Metal Turning Lathe with back gears and threading gears. . . **\$29.95**

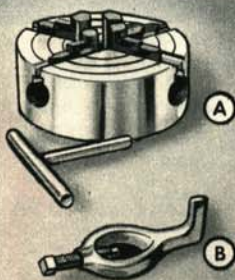

4-Jaw Chuck

A 4 reversible jaws move independently of each other. 3-in. diam. With key and back plate. Accurately machined. Fits 1/2-in. 24-thread spindle. For both lathes on this page. Shpg. wt., 3 lbs.

9 PT 2137 . . . \$4.75

Lathe Dog

B Holds work firmly. Heat treated set screw. Choice of 1/2, 3/4 or 1-in. Seat size. Shipping weight, 1 lb.

9 PT 2078 . . . 39c

24 . . . SEARS-ROEBUCK



Accessories for Above Lathes

- C** 9 PT 2108—No. 0 Morse taper spur center. Shipping weight, 3 ounces. . . . **59c**
- D** 9 PT 2109—No. 0 Morse taper cup center. Shipping weight, 3 ounces. . . . **59c**
- E** 9 PT 2103—No. 0 Morse taper 80-degree center. Shipping weight, 3 ounces. . . . **49c**
- F** 9 PT 2104—No. 0 Morse taper work arbor. Shipping weight, 5 ounces. . . . **75c**
- G** 9 PT 2132—1/2-inch 3-jaw chuck. Fits 1/2-inch 24-thread on 9PT2104. Shpg. wt., 12 oz. . . . **65c**

Threading Gears

H To be used on 99 PT 02053 DUNLAP lathe above at left. Will cut threads from 8 to 96 per inch. Complete with gear cover and threading dial. Shpg. wt., 10 pounds.

99 PT 2083 . . . \$9.95

Back Gears

I To be used on 99 PT 02053 DUNLAP lathe above at left. This unit assembly replaces regular headstock pulley. Gears are contained within pulley. Proper means are provided for throwing gears in or out of engagement. These back gears give slower spindle speeds and much greater power—both very desirable for efficient metal turning work. Shipping weight, 4 pounds.

9 PT 2082 . . . \$4.25



CRAFTSMAN MODEL MAKERS' LATHE

PRECISION BUILT! GUARANTEED ACCURATE WITHIN $\frac{1}{1000}$ INCH

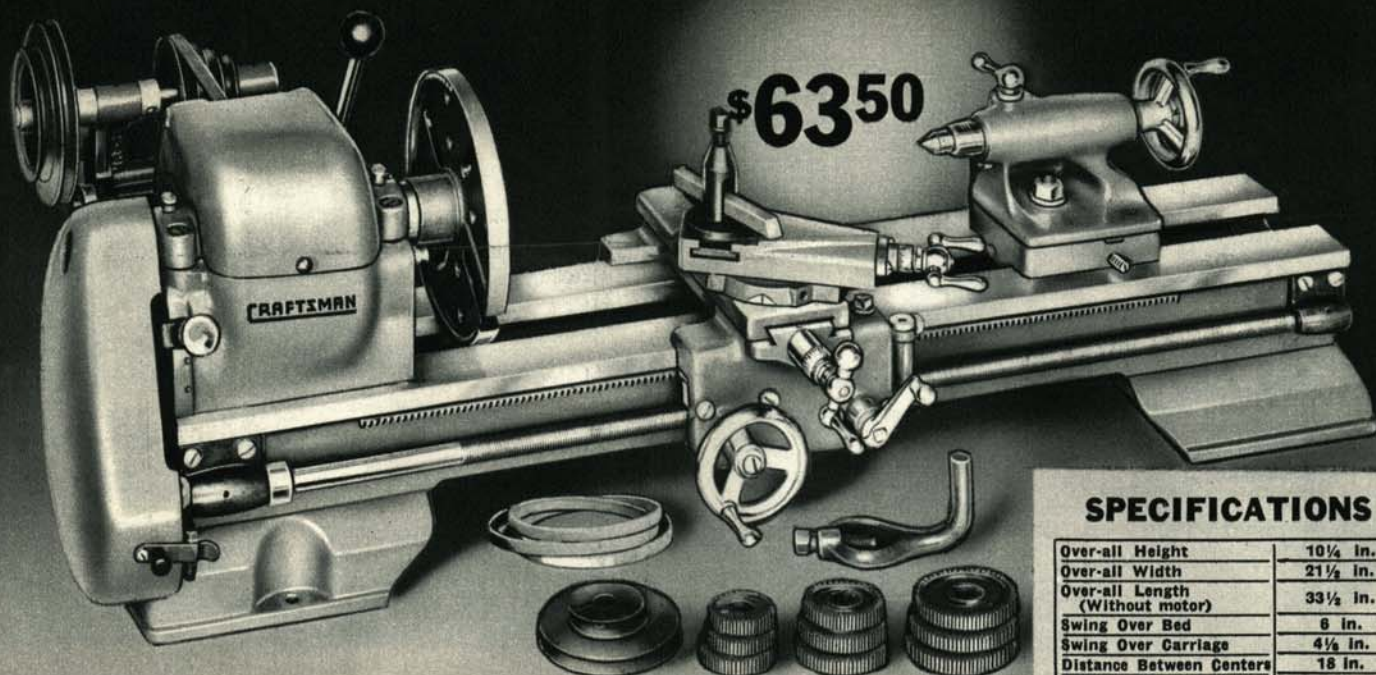

BACK GEARED . . 6-INCH SWING . . 30-INCH BED

- Back gears give 16 speeds—54 to 3225 R.P.M. A correct speed for all types of metal turning, finishing and polishing; woodworking and machining plastics.
- 1-inch ground steel spindle runs in adjustable auto-lubricating bronze bearings.
- Hinged countershaft and motor bracket built as part of lathe.

The only precision-built small metal working lathe ever offered at anywhere near this price! While it is smaller in capacity than our larger CRAFTSMAN screw cutting lathes (Pages 26 and 27), it actually matches them in accuracy, precision and performance!

The massive, semi-steel precision-ground bed is rigidly cross braced, and mounted on heavy gray iron legs. Extra heavy headstock, with adjustable bronze bearings gives rigid support to the spindle. Ball thrust bearing takes spindle thrust. Hinged guards for spindle pulley and feed gears give maximum safety. Carriage has hand wheel for manual operation and feed lever for reversible automatic power feed. Bench type

countershaft has quick belt release lever. Graduated compound rest swivels through 360 degrees. Spindle pulley has 60 indexing holes. Compound rest, carriage, etc. are fully gibbed for take-up. Tailstock has set-over for taper turning.

Equipment includes graduated compound rest, tool post, ring and rocker, $\frac{3}{8}$ -inch tool bit, bench type countershaft, motor pulley, belts, face plate, dog, two 60-degree lathe centers, threading dial, change gears, 3 wrenches, and complete, easy-to-follow instructions. Available on Sears Easy Terms. See inside back cover. Shipping weight, 110 pounds.

99 PTM 2048 \$63.50



SPECIFICATIONS

Over-all Height	10 1/4 in.	
Over-all Width	21 1/2 in.	
Over-all Length (Without motor)	33 1/2 in.	
Swing Over Bed	6 in.	
Swing Over Carriage	4 1/2 in.	
Distance Between Centers	18 in.	
Spindle Bearings { No. / Type	2 Oilite bronze	
Countershaft and Back Gear Bearings { No. / Type	4 Oilite bronze	
Spindle	Size Nose	8 3/4 x 1 3/8 in.
	Taper Hole	1-in. 8 R.H. thread No. 2 Morse 1 1/2 in.
Tailstock Taper	No. 1 Morse	
Back Gear Ratio	6 1/2 to 1 (Approx.)	
Feeds		41 .0024; .0039; .0048; .0078
	Thread Range	8 to 96 R.H. or L.H.
	Tailstock Ram Travel	1 1/4 in.
Cross Slide Travel	3 1/2 in.	
Compound Rest Travel	1 1/4 in.	
Tailstock Set Over	1/2 in.	
Speeds	16: 54 to 3225	
Motor Recommended	1/4 or 1/2-H.P. 1750 R.P.M.	
Recommended Mounting	99 PTM 2786, lathe stand	
Mounting Dimensions	4 3/4 x 27 1/2 in.	



Tool Holders

- Fit lathe above. Finest construction throughout. Special drop forged steel, heat treated and hardened. Accurately machined. Set screws are best alloy steel. Those holders using tool bits use $\frac{3}{8}$ -inch bits.
- A 9 PT 2037—Cut-Off Tool. Shipping weight, 14 oz. \$1.60
 - B 9 PT 2031—Threading Tool. Shipping weight, 14 oz. 2.75
 - C 9 PT 2033—Straight Tool Holder. Shpg. wt., 12 oz. 1.15
 - D 9 PT 2034—Right Hand Tool Holder. Shpg. wt., 12 oz. 1.15
 - E 9 PT 2035—Left Hand Tool Holder. Shpg. wt., 12 oz. 1.15
 - F 9 PT 2036—Knurling Tool. Shipping weight, 14 oz. 2.95

Formed Tool Bits

- G Set of six $\frac{3}{8}$ -inch bits to fit tool holders at left. High speed steel. Ground to shape. Shpg. wt., 5 oz. \$1.40
- 9 PT 2043—Set of 6. \$1.40

Tool Post Set

- H Set includes four boring bars, turning and threading tools, set of spacers. Shpg. wt., 14 oz. \$5.25
- 9 PT 2038. \$5.25

Reversing Switch

- J For reversing rotation of motor and spindle. Shpg. wt., 5 lbs. \$4.65
- 9 PT 2039. \$4.65

Face Plate

- K Fits 1-inch 8-thread spindle. Diameter, 3 1/2 inches. Shipping weight, 2 pounds. \$1.45
- 9 PT 2085. \$1.45

Independent Chuck

- L Four reversible jaws move independently of each other. 4 inches in diameter. Fits 1-in. 8-thread spindle. Shipping wt., 4 lbs. 2 oz. \$5.65
- 9 PT 2138. \$5.65

4-inch Universal Chuck

- M 3-jaw; self centering. Fits 1-in. 8-thread spindle. Shpg. wt., 4 lbs. 8 oz. \$14.95
- 9 PT 2148. \$14.95

Jacobs' Headstock Chuck

- N Accurate and convenient for holding small work. Capacity, 0 to 1/2 inch. Fits 1-inch 8-thread spindle. Shpg. wt., 4 lbs. \$9.45
- 9 PT 2044. \$9.45

Steady Rest

- P Gives additional support when turning long pieces in lathe. Shipping weight, 5 lbs. 8 oz. \$3.65
- 9 PT 2041. \$3.65

Follower Rest

- Q Mounts on back of carriage slide to support slender work. Shpg. wt., 3 lbs. 8 oz. \$2.65
- 9 PT 2042. \$2.65

Holding Collet

- R This tool will hold threaded-hole angular milling and keyway cutters and $\frac{1}{2}$ -inch end mill (See Page 28). Shipping weight, 2 lbs. \$5.75
- 9 PT 2059. \$5.75

Milling Attachment

- T Has a graduated swivel vise, flat block, and V-block to hold cylindrical objects. Vise capacity, 2-in. Vertical feed, 1 1/4 in. Graduated angular swivel. Shipping weight, 8 lbs. 8 oz. \$12.75
- 9 PT 2057. \$12.75

POWER TOOL . . 25

MASTER CRAFTSMAN LATHES

\$99⁵⁰

99 PTM 2065F

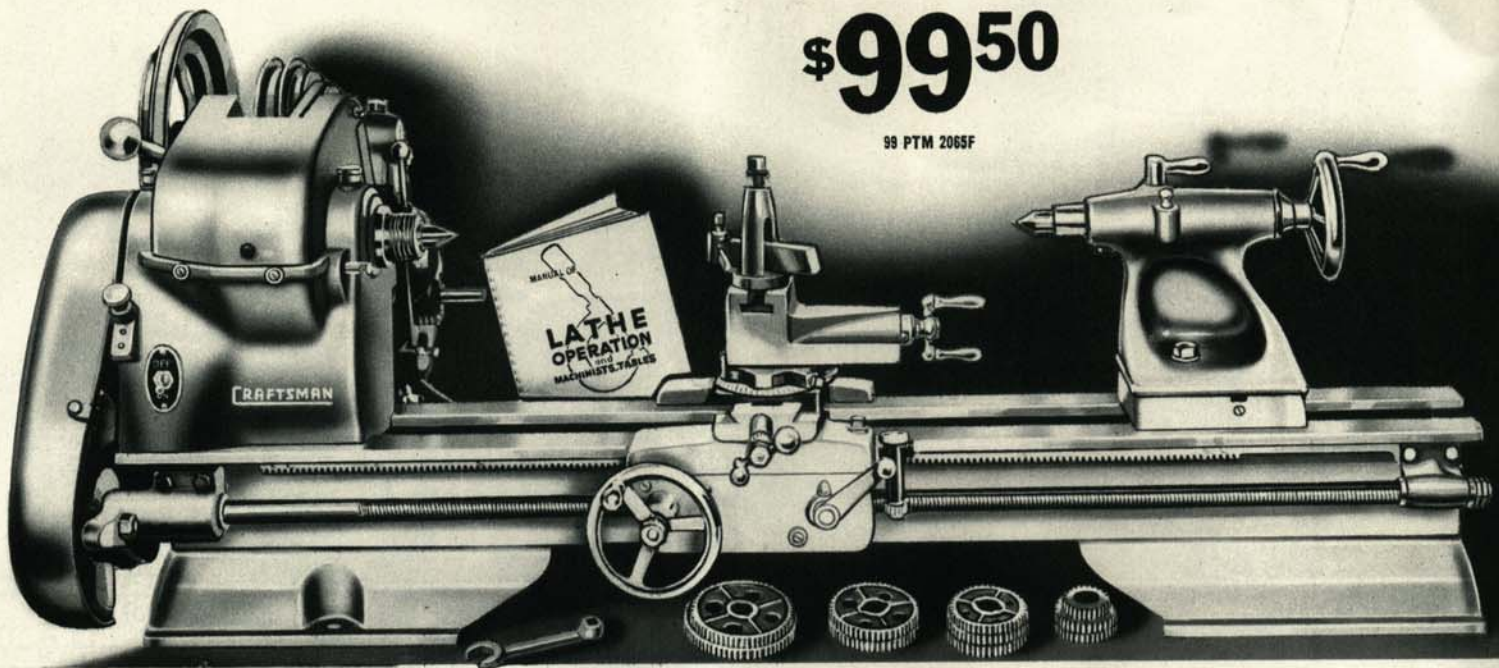

SPECIFICATIONS

Over-all Height	19 1/2 in.
Over-all Width	25 1/2 in.
Over-all Length	45 in. (42-in. bed)
Swing Over Bed	12 1/4 in.
Swing Over Carriage	8 3/4 in.
Main Spindle Bearings	2; babbitt
Countershaft and Back Gear Bearings	4; oilite bronze
Spindle	Nose Taper
	Hole
Tailstock Taper	No. 2 Morse
Back Gear Ratio	About 6 to 1
Lead Screw	5/8 in.; 8 Acme threads per in.
Feeds	.0024; .0035; .005; .0071; .0087
Thread Range	4 to 96; R.H. or L.H. (Std.). Also metric .5 to 7.0 M.M.
Tailstock Ram Travel	2 1/2 in.
Cross Slide Travel	6 in.
Compound Rest Travel	2 1/2 in.
Tailstock Set Over	3/4 in.
Speeds	16; 28 to 2072
Motor	1/2 or 1/3 H.P. 1750 R.P.M.
Countershaft Pulley Supplied	2-step, 9 1/4 in. and 7 1/2 diam.
Motor Pulley Supplied	2-step; 4 1/2 and 2-in. diam.
Recommended Mounting	99PTM2786 or 99PTM2787
Mounting Dimensions	6 1/2 x 35 1/8 in. (for 42-in. bed)

12-INCH SCREW CUTTING METAL LATHES

- Guaranteed accurate to within .001 inch. Precision construction in every detail!
- Semi-steel headstock has high speed line reamed babbitt bearings for long life
- Countershaft is integral part of lathe; a complete unit including motor mounting
- Thread range from 4 to 96 threads per inch, right and left hand (standard)

Built to meet the most exacting demands of master craftsmen! Thousands are in daily use in factories, garages and homes—wherever a truly fine lathe is desired.

Fine precision construction throughout! Careful tests must PROVE it is accurate to within .001 of an inch before it can leave the factory! Has heavily reinforced semi-steel bed with precision-ground ways. Heavy duty ball thrust bearing in headstock coupled with line reamed babbitt bearings insures smooth operation. Semi-steel tailstock has 3/4-inch set-over for taper turning; is fitted with center ejector and coordinating ram lock; ram is graduated in 16ths of an inch and has 2 1/2-in. travel. Non-slip V-belt drive has adjustable belt tension and release lever. Husky back gears (approx. 6 to 1 ratio)

may be cut in for slow speeds on heavy cuts. Heavy semi-steel carriage has adjustable gibs for take-up. Cross slide travel, 6 in.; compound rest travel, 2 1/2 in. Threading dial supplied as standard equipment. Cuts metric as well as standard threads. Compound rest swivels and locks at any angle and is graduated in one-degree divisions from 0 to 180 degrees. Reverse gear is controlled by lever at left of headstock.

Headstock is equipped with indexing device so work may be evenly divided or fluted. Back gears (which are included) give a wide range of 16 speeds. Complete with 234 page "Manual of Lathe Operation," threading gears, threading dial, V-belts, pulleys, wrenches, etc. Without motor. 99PTM2067 shipped from stock; others shipped from factory in southern Michigan.

MASTER CRAFTSMAN 16-speed, 12-inch screw cutting lathes equipped with back gears.

Catalog No.	Bed Length	Cap. Between Centers	Shpg. Wt.	Less Motor
99 PTM 2065F	36 in.	18 inches	245 lbs.	\$99.50
	STANDARD			
99 PTM 2067	42 in.	24 inches	255 lbs.	108.00
99 PTM 2069F	45 in.	30 inches	270 lbs.	116.00
99 PTM 2071F	54 in.	36 inches	275 lbs.	124.00



FOR ADDITIONAL METAL LATHE ACCESSORIES SEE PAGE 28



Workshop Manual

A Learn how to get the most out of your lathe. 234 pages of sound, practical, easy-to-follow instructions. Fully illustrated with photographs and drawings. Shipping weight, 1 pound.
9 PT 2925... 98c

Micrometer

B CRAFTSMAN. Made in U.S.A. to highest standards of accuracy. Graduated by 1/1000 of an inch. Lock nut, adjustable anvil; decimal equivalents on frame. Shipping weight, 8 ounces.
9 PT 4069
0 to 1 in. \$7.95

Center Gauge

C For checking lathe centers and setting threading tool. Shipping wt., 1 oz.
9 PT 4064..... 40c

Center Drill

D 3/8 or 1/2-in. State size. Countersink. Shpg. wt., 1 oz.
9 PT 2061..... 25c

No. 2 Morse Taper Centers and Arbors

E 9 PT 2111—60-Degree Center. Shipping weight, 7 ounces..... 65c
F 9 PT 2113—Precision Ball Bearing 80-Degree Center. Shpg. wt., 8 oz. \$2.25
G 9 PT 2125—Arbor and 1/2-in. Chuck. Shpg. wt., 1 lb. 8 oz. 1.29
H 9 PT 2163—Arbor. Shipping weight, 13 ounces..... 89c
J 9 PT 2161—Adapter Sleeve. To change from No. 2 to No. 1 Morse taper. Shipping weight, 5 ounces..... 59c

Lathe Accessories

K 9 PT 2187—Drill Pad. Shpg. wt., 1 lb. 2 oz. \$1.20
L 9 PT 2114—Crotch Center. For centering round work for tailstock drilling. Shpg. wt., 1 lb. 1.20
M 9 PT 2124—Arbor. For Jacobs' drill chuck. Shpg. wt., 7 oz. 75c
N 9 PT 2126—Chuck Arbor. For use with center rest chuck or spindle nose chuck. Shipping weight 10 ounces 98c

MASTER CRAFTSMAN DE LUXE

\$129⁰⁰

99 PTM 2073F

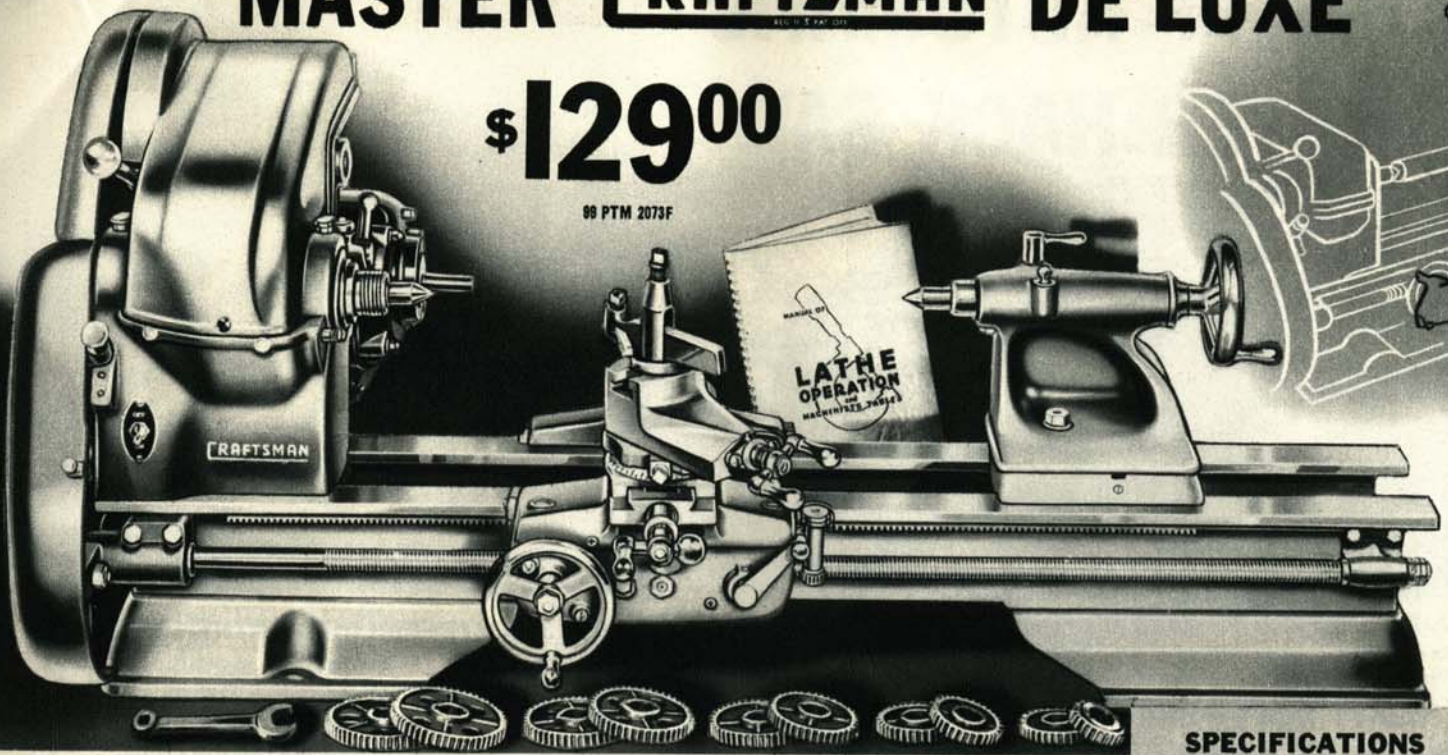

GUARANTEED ACCURATE TO .001 INCH

This is by far the finest lathe we have ever sold! Precision built! Super quality in every detail, with features usually considered special equipment! Has ALL the fine features of our famous MASTER CRAFTSMAN 16-speed lathes shown on the opposite page—PLUS many important improvements and refinements of design which you can't match anywhere in this price range! For example, it has famous TIMKEN tapered roller bearings to assure the very finest performance, even at high spindle speeds. These aren't just standard TIMKEN bearings, but are specially selected—the same type as used in large machine tools selling for thousands of dollars! They're actually the finest bearings known for metal-cutting lathes!

Easy Formed!
ON ORDERS OF \$10 OR MORE—SEE INSIDE FRONT COVER

This lathe is regularly equipped with a reversible power cross feed—just pull the knob and do your facing work much more accurately—automatically! Belt-guards completely cover headstock and motor drive pulleys, to meet safety code regulations; easily opened to change speeds. Complete as shown, with belt guards, selected Timken bearings, power cross feed and all equipment supplied on standard MASTER CRAFTSMAN lathes. Without motor. 99PTM2075 shipped from stock; others from southern Michigan.

Catalog No.	Bed Length	Between Centers	Shpg. Wt.	Less Motor
99PTM 2073F	36 in.	18 inches	265 lbs.	\$129.00
	STANDARD			
99PTM 2075	42 in.	24 inches	270 lbs.	\$137.00
99PTM 2077F	48 in.	30 inches	285 lbs.	\$146.00
99PTM 2079F	54 in.	36 inches	290 lbs.	156.00

SPECIFICATIONS

Over-all Height	20 in.
Over-all Width	25½ in.
Over-all Length	45 in. (42-in. bed)
Swing Over Bed	12½ in.
Swing Over Carriage	8½ in.
Spindle Bearings	2; Timken roller
Cross Feed	Reversible; power feed
Belt Guards	Fully cover all belts.
Thread Range	4 to 96
Speeds	16: 28 to 2072
Motor	¼ or ½-H.P.; 1750 R.P.M. 99PT01955 or 99PT05584
Recommended Mounting	99PTM2786 or 99PTM2787
Mounting Dimensions	6½x35½ in. (for 42-in. bed)
Other dimensions	See table on Page 26.



Tool Holders

Steel forgings, carefully finished. For ¼-in. tool bits. Shanks are ½ inch high; ⅜ inch wide. Shipping weight, each, 2 lbs.

- (A) 9 PT 2192—Offset, right \$1.25
- (B) 9 PT 2194—Offset, left \$1.25
- (C) 9 PT 2196—Straight... 1.25
- (D) 9 PT 2198—Threading... 2.65
- (E) 9 PT 2200—Cut-off... 1.60
- (F) 9 PT 2202—Knurling tool 3.25

6 Formed Tool Bits

¼-in. High speed steel. Fit holders at left. Shipping wt., 8 oz. Set includes:

- (G) Threading bit.
 - (H) L.H. facing bit.
 - (J) R.H. turning bit.
 - (K) Round nose turning bit.
 - (L) R.H. facing bit.
 - (M) L.H. turning bit.
- 9 PT 2205—Set of 6 \$1.50

Tool Post Tool Set

Includes set of tool post spacers; 4 boring tools (⅜, ⅜, ⅜, ⅜-in.); ¼-in. inside threading tool; ⅜-in. turning tool, and ⅜-in. threading tool. Shpg. wt., 2 lbs.

9 PT 2189... \$4.95

Micrometer Carriage Stop

Handy for boring or facing to a given depth; cutting off at a given point; duplicating longitudinal cuts; and laying out work on a cylindrical surface. Clamps on front bed way. An aid to better work. Shipping weight, 1 pound.

9 PT 2185... \$3.45

Reversing Switch

Drum type switch. Essential for grinding and tapping, all types of fine metal and wood finishing. By reversing motor permits changing direction of rotation of lathe spindle. (Not for repulsion-induction motors.) Durable contacts for long life. With cord and plug. Shpg. wt., 5 lbs.

9 PT 2983... \$4.35



Face Plates

- (A) For any lathe with 1½-inch, 8-thread spindle as in lathes on these two pages.
- 9 PT 2097—3½-inch. Shipping wt., 2 lbs. \$1.45
- 9 PT 2098—6-in. Shpg. wt., 3 lbs. \$1.95
- 9 PT 2087—8½-inch. Shpg. wt., 6 lbs. \$4.10

Scroll Chuck

- (B) 5-inch, 3-jaw, self-centering chuck. For centering round or hexagonal work. All jaws are moved by turning one screw. Fits 1½-inch 8-thread spindle as on lathes on these two pages. Supplied with two sets of jaws (inside and outside). Shpg. wt., 6 lbs. 11 oz.
- 9 PT 2150... \$18.50

Independent Chucks

- (C) The toolmaker's choice for precision work. Four reversible jaws, hardened and tempered. For 1½-inch 8-thread spindle such as on lathes on these two pages.
- 9 PT 2139—6-in. Shpg. wt., 8 lbs. 12 oz. \$9.95
- 99 PT 02141—Heavy duty. 8-inch. Shipping weight, 22 pounds. \$16.95

Jacobs' ½-in. Chuck

- (D) When fitted with arbor 9 PT 2124 (on opposite page), it may be used either in lathe head or tailstock for holding drill bits. Shipping weight, 2 pounds.
- 9 PT 2142 ¼ to ½-inch... \$5.65
- 9 PT 2143—0 to ½-inch... \$6.65

Jacobs' Chucks

- (E) Spindle nose. Hollow; capacity ¼ to ⅝-inch. Used on tail-stock of lathe with adapter 9 PT 2126 (Page 26). Shpg. wt., 4 lbs.
- 9 PT 2144... \$11.75
- (F) Center rest. Use in tail-stock to hold centerless armatures on 9PT2126 adapter. Shpg. wt., 3 lbs.
- 9 PT 2991... \$7.95

Lathe Dogs

- (G) Drop forged. Hold work firmly. Heat treated set screws. Be sure to state size.
 - 9 PT 2183
- | Size | Shpg. Wt. | Price |
|--------|-----------|-------|
| ½ in. | 1 lb. | 50c |
| ¾ in. | 1 lb. | 60c |
| 1 in. | 1 lb. | 70c |
| 1½ in. | 1 lb. | 80c |

DUNLAP AUTOMATIC POWER HACK SAW

\$27⁵⁰

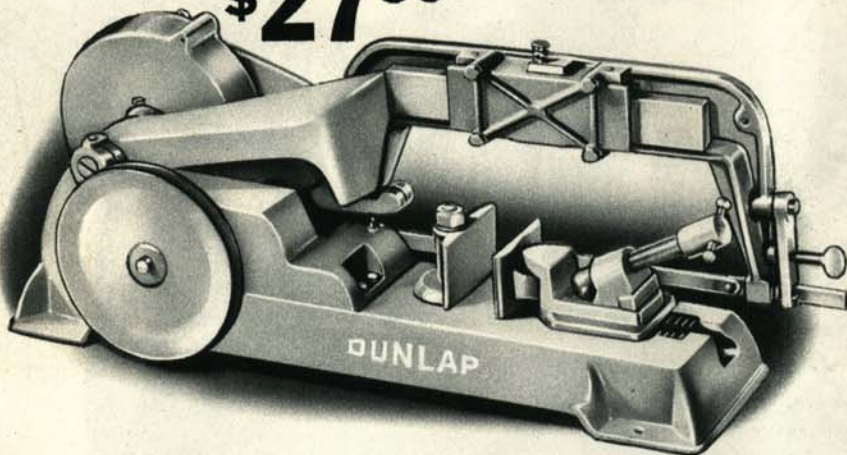

HEAVY DUTY—BUILT FOR YEARS OF SERVICE

Here's a machine that takes all the hard work out of a tough job. What a work-saver it is! You can do another job while it finishes the cut alone! Built for years of dependable service. It's a draw cut machine with an automatic relieving mechanism. The blade lifts from the work on the return stroke, thus increasing blade life and efficiency. Takes material up to 4x4 in. Finest quality extra large bronze bearings. Cuts any angle from 90 to 45 degrees. Takes any standard 12-in. power hack saw blade. Mounting dimensions, 5 1/4 x 19 1/2 in. Over-all length, 29 1/2 in.

99 PTM 2294—Shipping weight, 80 pounds..... \$27.50
 9 PT 6580—CRAFTSMAN 12-inch Power Blades. 14 teeth to the inch. 3/8 in. wide. .032 in. thick. Shipping weight, 1 pound 2 ounces. Dozen..... 95c

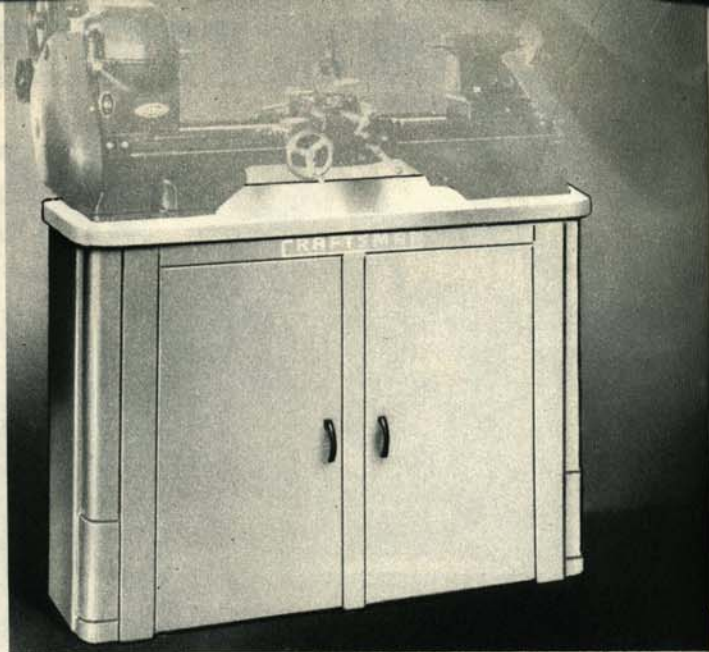

CRAFTSMAN STREAMLINED LATHE CABINET

\$23⁹⁵

45-inch

To get the most accurate work out of your lathe it must be mounted perfectly level on a rigid base. This cabinet provides the mounting and also provides space for your tools. Beautifully streamlined! Fully enclosed! Welded steel construction. Has a heavy, smoothly finished mounting board on top. Two large doors with piano type hinges and snap catch locks. Large steel shelf furnishes a convenient storing place for chucks, change gears, tools, etc. Height, 32 1/4 inches. Width, 14 inches. Choice of 45 or 57-inch length.

99 PTM 2786—45-inch length. For lathes with beds up to and including 44 inches. Shipping weight, 95 pounds..... \$23.95
 99 PTM 2787—57-inch length. For lathes with beds up to and including 54 inches. Shipping weight, 116 pounds..... \$27.95

CRAFTSMAN Metal Lathe Accessories

Universal Tool Post Grinder

Grinds valves and cutters at any angle. Also pistons, bushings, reamers, valve stems, and lathe centers. Undercuts mica. Complete with motor, external and internal grinding wheels, quill for internal grinding, 5 mica undercutting saws and diamond wheel dresser. Universal motor for 110-120-volt D.C. or A.C. 25-60 cycles. Shpg. wt., 23 lbs.

99PT02998...\$48.50

Taper Attachment

An accurate taper attachment at a very moderate price. Easily installed—simple to operate. With this attachment it is not necessary to move the tailstock center out of alignment. Duplicate tapers can be cut accurately on pieces of different lengths. Boring work can be done as easily as external work. Index plate is graduated 7° and 3 in. both sides of center line. Fits old or new model CRAFTSMAN lathes. Shpg. wt., 10 lbs.

9 PT 2984...\$15.45

ON ORDERS OF \$10 OR MORE
 SEE INSIDE FRONT COVER
Easy Terms!

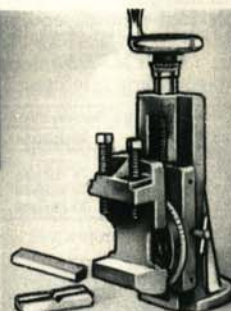

Milling Attachment

Designed to fit Sears screw cutting lathes on Pages 26 and 27. Has graduated swivel vise, V-block for holding cylindrical objects. Vise capacity, 2 3/4 in. Vertical feed, 2 3/4 in. Micrometer graduated feed screw. Angular swivel accurately graduated in degrees. Shipping weight, 16 pounds.

99 PT 02987.....\$15.45



Mica Undercutter

Fastens to back of carriage; goes into action in a jiffy. May be moved out of way when not in use. Universal motor for 110-120-volt D.C. or A.C. 25-60 cycles. With switch, cord and set of 5 undercutting saws. Shipping weight, 10 pounds.

9 PT 2989...\$19.50



Follower Rest

Gives necessary rigid support for jobs requiring a long cut on small diameters. Insures accurate work. Fastens to back of carriage dovetail slide—follows cutting tool. Shipping weight, 4 pounds.

9 PT 2988\$3.25



Steady Rest

Brass jaws give rigid support to insure accuracy in turning, boring and threading long, slender pieces in the lathe. Clamps to bed ways. Capacity up to 2 3/4 inches. Shipping weight 7 pounds.

9 PT 2050\$4.95

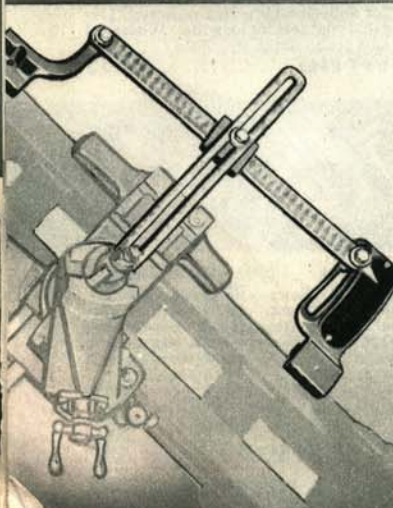

High Speed Steel Milling Cutters

A Angular Type. For face milling or dovetailing. Use with threaded adapters supplied with Holding Collet 9 PT 2994. Shpg. wt., each, 3 oz.

9 PT 2995—State size.			
Diam., In.	Thick., In.	Holz., In.	Price
1 1/4	3/8	3/4	\$3.95
1 1/2	3/8	3/4	4.45

B Wood-ruff Keyway Cutters. Well made; ground. 1/2-in. shank. Shpg. wt., each, 4 oz. State size.

9 PT 2996		
Diam., In.	Thick., In.	Price
1/2	3/8	\$2.50
3/4	3/8	2.75
1	3/8	3.35
1 1/4	3/8	3.75
1 1/2	3/8	4.25

C R.H. Cut, R.H. Spiral End Mills. Used with 9 PT 2994 and 9PT2985. Shpg. wt. each, 3 oz. State size.

9 PT 2997		
Diam., In.	Flute, In.	Price
3/16	3/16	\$1.65
1/8	1/8	1.75
3/16	3/16	1.85
1/4	1/4	2.10
5/16	5/16	2.25

Holding Collet

D For threaded-hole angular milling and keyway cutters, and 1/2-in. end mill. Shpg. wt., 3 lbs.

9 PT 2994\$5.95

9 PT 2985—4 bushings for use with 1/2, 3/16, 3/8, 7/16-in. end mills. Shipping wt., 4 oz.\$1.70