

Sears

owners manual

**CRAFTSMAN**  
**10-INCH**  
**TILTING ARBOR**  
**BENCH SAW**

MODEL No.  
113.29940

**CAUTION:**  
Read Rules for  
Safe Operation  
and Instructions  
Carefully

- Assembly
- Operating
- Repair Parts

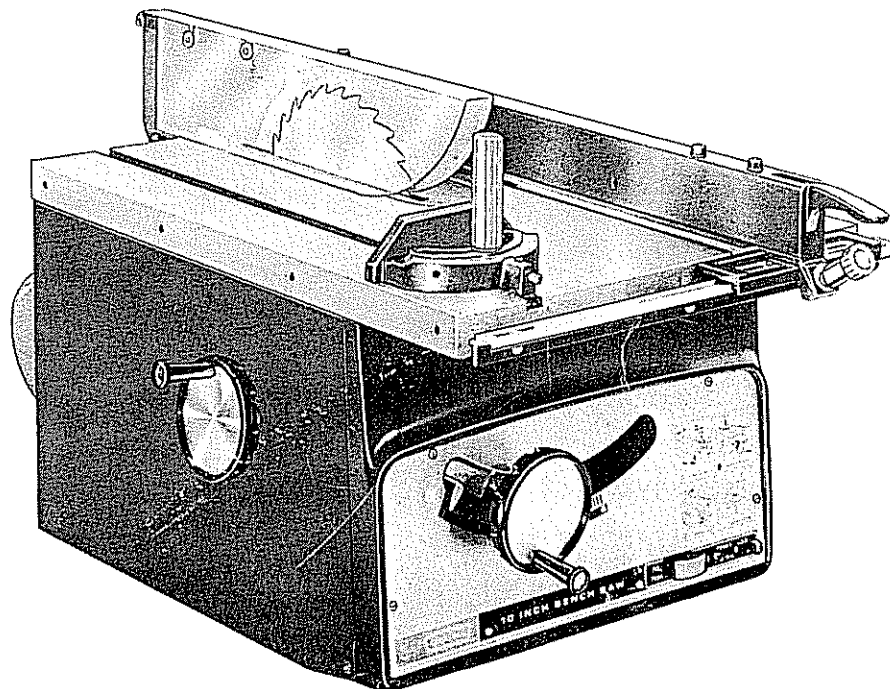

**SEARS, ROEBUCK AND CO. U.S.A.**  
SIMPSONS-SEARS LIMITED, CANADA

**CRAFTSMAN**

## **SAFETY RULES FOR POWER TOOLS**

### **1. KNOW YOUR POWER TOOL**

Read owner's manual carefully. Learn its applications and limitations as well as the specific potential hazards peculiar to this tool.

### **2. GROUND ALL TOOLS — UNLESS DOUBLE-INSULATED**

If tool is equipped with three-prong plug, it should be plugged into a three-hole electrical receptacle. If adapter is used to accommodate two-prong receptacle, the adapter wire must be attached to a *known ground*. Never remove third prong.

### **3. KEEP GUARDS IN PLACE**

and in working order.

### **4. KEEP WORK AREA CLEAN**

Cluttered areas and benches invite accidents

### **5. AVOID DANGEROUS ENVIRONMENT**

Don't use power tool in damp or wet locations, and keep work area well lit.

### **6. KEEP CHILDREN AWAY**

All visitors should be kept safe distance from work area

### **7. STORE IDLE TOOLS**

When not in use, tools should be stored in dry, high or locked-up place — out of reach of children.

### **8. DON'T FORCE TOOL**

It will do the job better and safer at the rate for which it was designed.

### **9. USE RIGHT TOOL**

Don't force small tool or attachment to do the job of a heavy duty tool.

### **10. WEAR PROPER APPAREL**

No loose clothing or jewelry to get caught in moving parts. Rubber gloves and footwear are recommended when working outdoors.

### **11. USE SAFETY GLASSES**

with most tools. Also face or dust mask if cutting operation is dusty.

### **12. DON'T ABUSE CORD**

Never carry tool by cord or yank it to disconnect from receptacle. Keep cord from heat, oil and sharp edges.

### **13. SECURE WORK**

Use clamps or a vise to hold work. It's safer than using your hand and it frees both hands to operate tool.

### **14. DON'T OVERREACH**

Keep proper footing and balance at all times.

### **15. MAINTAIN TOOLS WITH CARE**

Keep tools sharp at all times, and clean for best and safest performance. Follow instructions for lubricating and changing accessories.

### **16. DISCONNECT TOOLS**

When not in use, before servicing; when changing accessories such as blades, bits, cutters, etc.

### **17. REMOVE ADJUSTING KEYS AND WRENCHES**

Form habit of checking to see that keys and adjusting wrenches are removed from tool before turning it on.

### **18. AVOID ACCIDENTAL STARTING**

Don't carry plugged-in tool with finger on switch.

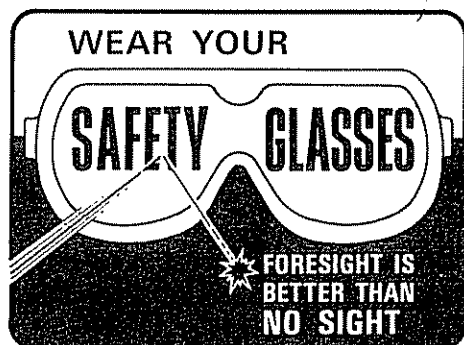

Copyright, 1969, by Power Tool Institute, Inc. All Rights Reserved.

The operation of any power tool can result in foreign objects being thrown into the eyes, which can result in severe eye damage. Always wear safety glasses or eye shields before commencing power tool operation. We recommend **Wide Vision Safety Mask** for use over spectacles, or standard safety glasses . . . available at Sears retail or catalog stores.

# INSTRUCTIONS TO OPERATOR

Be sure to read the following instructions carefully before operating the saw.

**WARNING:** Do not connect power cord until the following steps have been satisfactorily completed:

- a. Assembly and Installation.
- b. Examination and operating familiarity with ON-OFF switch, elevation control, bevel control, miter gauge, and rip fence.
- c. Review and understanding of the operating procedures which follow.

**CAUTION:** Always disconnect the power cord when removing the table insert, changing the cutting tool, or making adjustments

1. The saw should be bolted down if there is any tendency to tip over or move during normal operations. The saw table should be approximately 36-inches above the floor.
2. The saw work area should have adequate overhead, non-glare light and adequate surrounding work space.
3. The saw should be positioned so neither the operator nor a casual observer is forced to stand in line with a potential kick-back.
4. A large proportion of tilting arbor saw accidents is caused by dull, badly set, improperly filed cutting tools, and by gum or resin adhering to cutting tools. Such conditions cause the material to stick, jam, stall the saw, or kick-back at the operator. Cracked saw blades should be discarded immediately. A saw blade can become cracked if it wobbles or if it is not in balance. Avoid potential injury by proper cutting tool and machine maintenance.
5. Gloves should not be worn while operating the saw. Loose flowing garments, jewelry (rings, wrist watches, etc.), and neckties should never be worn. Long sleeves should be rolled to above the elbows.
6. Goggles or an eye shield should always be used. Ear protectors (ear plugs or muffs) should be used during extended periods of operation.
7. Provide proper support for the workpiece, based on its size and the type of operation to be performed; hold the work firmly against the gauge or guide. Use a push stick when ripping short work (under 6-inches long), or narrow work. A push block or miter gauge hold-down should be used when dadoing or molding.
8. Never use a length stop (such as the fence when cross-cutting) on the free end of the workpiece, unless a block is fastened to the fence. Never hang onto or touch the free end of workpiece or a free piece that is cut off, while power is on.
9. Cross-cutting operations are more conveniently worked and with greater safety if the miter gauge is fitted with an auxiliary wood facing.
10. Do not leave a long board unsupported so the spring of the board causes it to shift on the table. A support should be used to catch the end of the board behind the blade.
11. Always disconnect the saw from the power source before making adjustments. Never climb on or near the saw when power is on. Never leave the saw with power on, or before the cutting tool has come to a complete stop.
12. Avoid awkward hand positions, where a sudden slip could cause a hand to move into a saw blade or other cutting tool. Never reach in back of the cutting tool with either hand to hold down the workpiece.
13. Make sure the top of the arbor or cutting tool rotates toward you when standing in normal operating position. Also make sure the cutting tool, arbor collars and arbor nut are installed properly. Keep the cutting tool low for safest operation. Keep all guards in place whenever possible.
14. Do not use any blade or other cutting tool marked for an operating speed in excess of the design speed of the saw. Never use a cutting tool larger in diameter than the diameter for which the saw was designed. For greatest safety and efficiency when ripping, use the maximum diameter blade for which the saw is designed, since under these conditions the splitter (spreader) is nearest the blade.
15. Adjust table inserts flush with the table top.
16. For operations which do not permit the use of a splitter (spreader), serious consideration should be given to the use of jigs or fixtures to hold the work so the hands of the operator are removed a safe distance from the point of operation.
17. The use of abrasive or cut-off wheels, or wire wheels can be dangerous and is not recommended. (Abrasive or cut-off wheels are used to saw many different materials including metals, stone, and glass.)
18. Safety is a combination of operator common sense and alertness at all times when the saw is being used.

**WARNING:** Do not allow familiarity (gained from frequent use of your saw) to become commonplace. Always remember that a careless fraction of a second is sufficient to inflict severe injury.

## CONTENTS

	Page		Page
Unpacking and Pre-Assembly		Operating Controls	18
Instructions	4	Proper Operating Procedures	19
Assembly and Adjustments	5	Trouble Shooting	23
Motor Specifications and Mounting	13	Repair Parts	24

# unpacking and pre-assembly

## TOOLS NEEDED

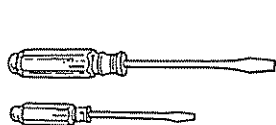

Screwdriver (medium)  
Screwdriver (small)

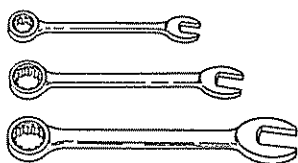

7/16-inch wrench  
1/2-inch wrench  
9/16-inch wrench

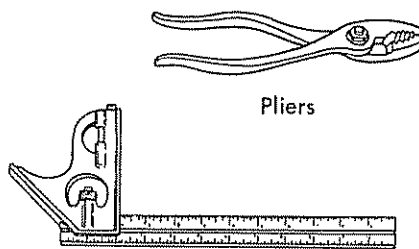

Square (combination square, try square, or both)



Rubber mallet

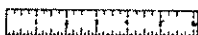

Small steel scale



Pencil

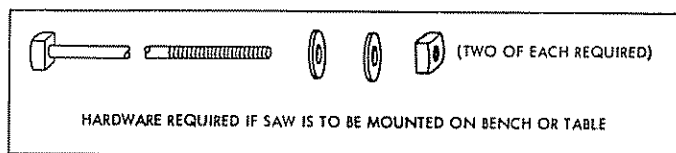

**NOTE:** An arbor wrench, for removing or installing the saw arbor nut, and all necessary hex-L wrenches are supplied with the saw. (Refer to the "Loose Parts List".) Hardware required to attach the saw to a bench or table is not supplied. (Two 3/8-inch diameter bolts; length determined by thickness of table top; four 3/8-inch flat washers; and two 3/8-inch nuts.)

## UNPACKING AND PRE-ASSEMBLY INSTRUCTIONS

### UNPACKING AND CHECKING CONTENTS

This Craftsman Bench Saw is shipped complete in one carton (without motor).

In order to prevent damage during shipment and facilitate packaging, certain items have been removed at the factory and must be assembled when received by the purchaser. Remove all items from the package and identify them by referring to figure 1. These "loose" parts are listed below and should be accounted for before discarding any packing material. (See figure 1.)

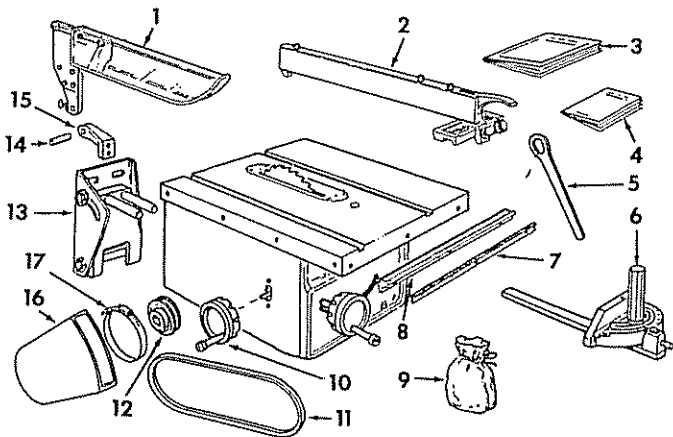

Figure 1

### LOOSE PARTS LIST

Key No. (Fig. 1)	Part Name	Qty.
1	Guard Assembly — Saw	1
2	Fence Assembly — Rip	1
3	Operating Instructions	1
4	Handbook	1
5	Wrench, Arbor	1
6	Gauge Assembly — Miter	1
7	Rack — Table	1
8	Bar Assembly — Fence	1
9	Bag of Loose Parts	1
10	Hand-Wheel Assembly, Tilt 4-1/2 in.	1
11	V-Belt, 1/2 x 41 in.	1
12	Pulley — V, Single Groove, 2-1/2 x 5/8 in. Bore	1
13	Support Assembly — Motor	1
14	Rod Assembly — Splitter	1
15	Support Assembly — Splitter	1
16	Guard, Belt	1
17	Clamp, Ring	1
<b>Contents of Loose Parts Bag — (Key No 9, above)</b>		
	Wrench, Hex-L, 3/32 in.	1
	Wrench, Hex-L, 1/8 in.	1
	Wrench, Hex-L, 5/32 in.	1
	Wrench, Hex-L, 3/16 in.	1
	Wrench, Hex-L, 1/16 in.	1
	Bolt, Carriage, 5/16-18 x 3/4 in.	4
	Nut, Square, 5/16-18	4
	Washer, 11/32 x 7/8 x 1/16 in.	4
	Lockwasher, 5/16 x .125 x .078 in.	4
	Screw, Mach, Hex Hd., 5/16-18 x 5/8 in.	2
	Spacer, Fence Guide Bar	3
	Screw, Mach., Rd-Hd, Slotted, 1/4-20 x 2 in.	3
	Nut, Hex, 1/4-20 x 7/16 x 3/16 in.	3
	Lockwasher, 1/4 x .109 x .062 in.	3
	Screw, Mach., Hex-In-Hd., 5/16-18 x 1 in.	2
	Key (for Switch Lock)	2
	Grommet	1
	Clip, Cord	2

# assembly and adjustments

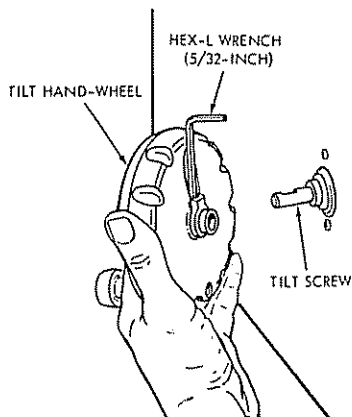

Figure 2

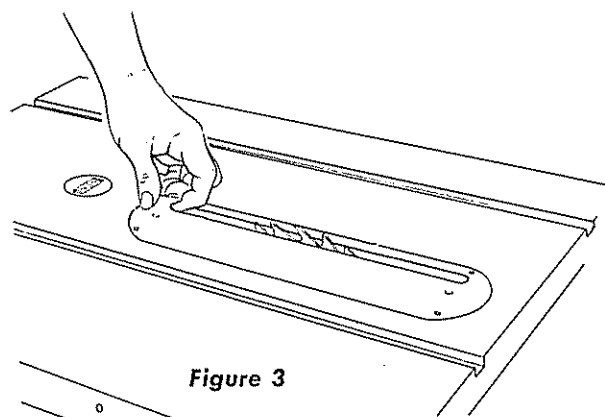

Figure 3

## GENERAL INFORMATION

The instructions in this manual are presented in step-by-step order and illustrated by numerous pictorial diagrams. Read the instructions and observe the illustrations to insure a correctly assembled and accurately adjusted saw. Adjustments are carefully checked prior to packaging the saw for shipment; however, rough handling in transit may necessitate some readjustments. For this reason all adjustments are presented in logical order. Reference to the Repair Parts exploded drawings (and item listings) may be helpful in acquiring a more thorough understanding of your Craftsman saw.

## ASSEMBLY AND ADJUSTMENTS

1. Remove the rust-preventive coating from external surfaces (saw table, etc.) with a cloth moistened with kerosene.
2. Install the tilt hand-wheel on tilt screw shaft and secure it by tightening the set screw with a 5/32-inch hex-L wrench. (See figure 2.) Be sure to tighten the set screw on the "flat" of tilt screw.
3. Rotate the tilt hand-wheel clockwise until it stops, to set the saw blade in the vertical (90°) position.
4. Remove the table insert, by inserting a finger into the slot at one end of the insert and lifting it upward and out. (See figure 3.)
5. Rotate the elevation hand-wheel clockwise until it stops. This will position the saw blade at maximum height (deepest cut) position. (See figure 4.)
6. Check tightness of saw arbor nut by wedging a small block of wood between the saw blade and table opening, as shown in figure 5, and, using the arbor wrench supplied with the saw, tighten the nut. (The nut rotates clockwise to tighten.)
7. Adjust Stop Collars as Follows:
  - a. Checking and Adjusting the 0° Position.
    - (1) With the saw blade in deepest cut position, check the tilt position of the saw blade by attempting to rotate the tilt hand-wheel clockwise until it will rotate no farther.
    - (2) Place a square on the table top and against saw blade. (See figure 6.) The blade should be at exactly 90 degrees (perpendicular) to the table-top surface. (Make sure the square is resting against the flat surface of blade and is not being held away by the "tooth-set" of the blade.)

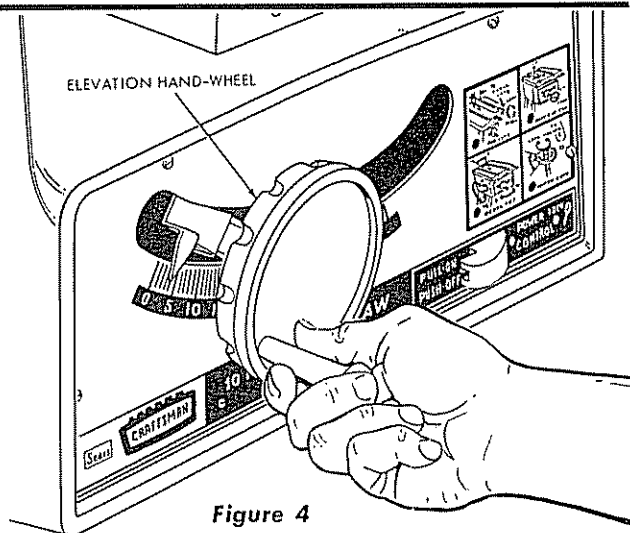

Figure 4

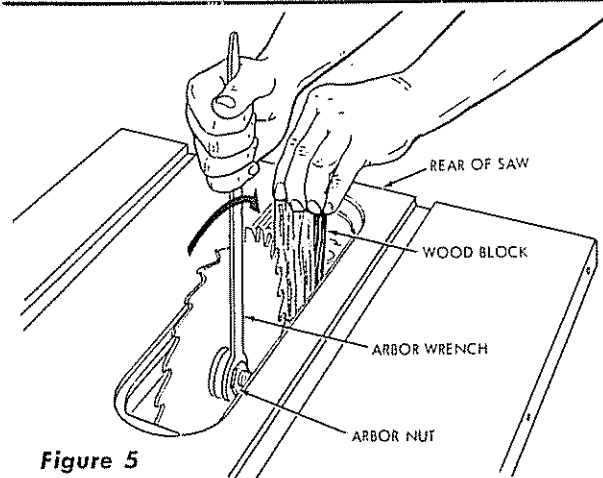

Figure 5

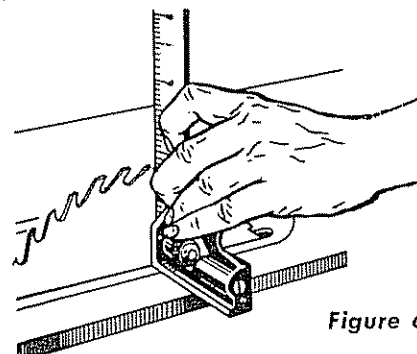

Figure 6

# assembly and adjustments

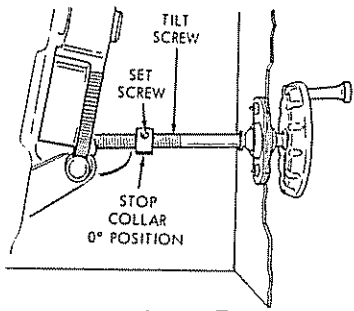

Figure 7

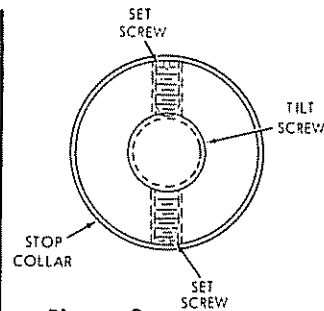

Figure 8

(3) If the blade is not square with table top, rotate the tilt hand-wheel counterclockwise until the tilt mechanism moves a short distance away from the stop collar on tilt screw. When the pointer on tilt scale indicates approximately 10 degrees, the stop collar can be reached. (See figures 7 and 9.)

(4) Loosen the two set screws in the stop collar, located on the tilt screw nearest tilt hand-wheel, with a small screwdriver and rotate the stop collar counterclockwise at least one turn. (See figures 7 and 8.)

Two slotted-head set screws (figure 8) are used in each stop collar so that one of the screws will always be accessible (with operator reaching inside the saw base from the rear of saw, figure 9). After adjusting the collar, it is only necessary to tighten one of the set screws to secure the collar on the tilt screw.

(5) Rotate the tilt hand-wheel clockwise until the saw blade is perpendicular to the saw table — measuring it with the square, as shown in figure 6.

(6) Reach inside of saw base (figure 9) and rotate the stop collar clockwise until it is in firm contact with the saw cradle. Tighten one of the stop-collar set screws enough to keep the collar from rotating on the tilt screw.

(7) Rotate the tilt hand-wheel counterclockwise approximately three turns, then rotate it clockwise until it stops. Check the saw again with the square as shown in figure 6. If the adjustment is correct (blade square with table surface), tighten the set screw in the stop collar securely.

**NOTE:** Several trial adjustments may be required in order to produce an accurate adjustment of the stop collar. If the first trial fails to produce an accurate setting, it is suggested that the operator determine which direction the stop collar needs to be rotated for a correction and turn the collar in small increments (checking each time) until the adjustment is correct. Be sure to tighten one of the collar set screws after each adjustment to prevent the collar from slipping on the tilt screw when it comes into contact with the saw cradle.

(8) With the tilt hand-wheel rotated clockwise until it stops (saw blade 90° with table surface), check the tilt pointer on tilt gauge which should be at exactly "0" (zero) degrees. (See figure 10.) A close look will show a reflection of the pointer tip on the mirror surface of the tilt scale on front panel. In order to make sure that you are sighting squarely with the scale, move your eye until the tip of the pointer and its reflected image coincide.

(9) If the pointer is not aligned with the "0" mark, bend the pointer carefully with pliers (figure 10) until it remains at "0" when the pliers are removed.

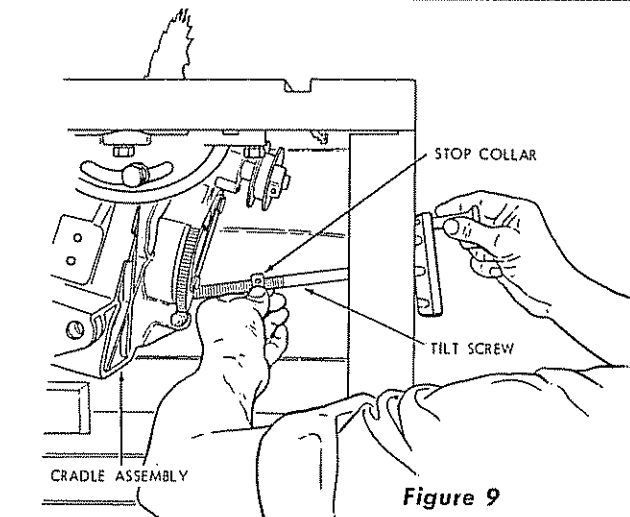

Figure 9

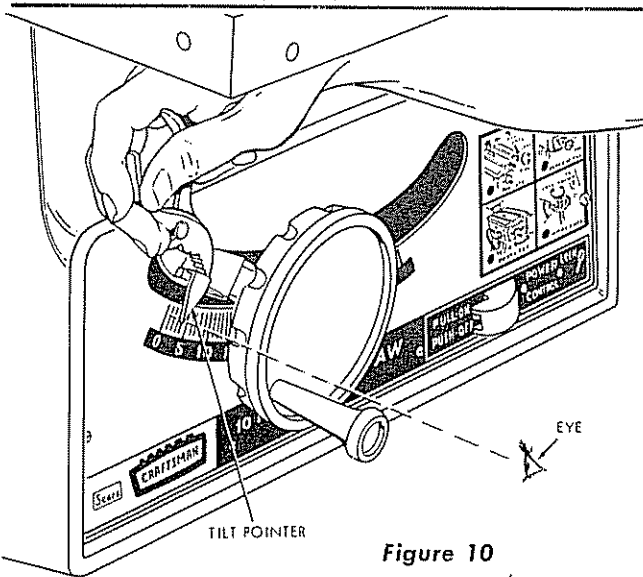

Figure 10

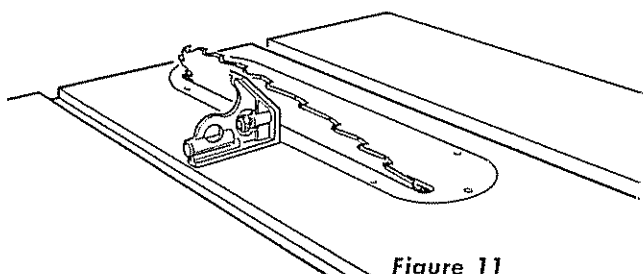

Figure 11

b. Checking and Adjusting the 45° Position.

- (1) Rotate the tilt hand-wheel counterclockwise until it will rotate no farther.
- (2) Remove the scale from a combination square and place the head of the square on table top and against saw blade. (See figure 11.) The saw blade should be setting at exactly 45 degrees with table top surface.
- (3) If the acute angle between saw blade and table top is not 45 degrees, rotate the tilt hand-wheel clockwise until the tilt mechanism moves a short distance away from the stop collar (located farthest out toward the end of tilt screw, figure 12) so the collar can be reached for an adjustment. When the tilt scale indicates approximately 35 degrees the collar will be accessible.
- (4) Loosen the two set screws in the stop collar. (See figures 8 and 12.) If, in preceding step (2), the blade stopped with the acute angle greater than 45 degrees, rotate the stop collar counterclockwise (toward end of tilt screw). If the angle is less than 45 degrees, rotate the collar clockwise (away from end of tilt screw). For each trial setting: move the stop collar a short distance away from saw cradle (by rotating tilt hand-wheel clockwise) loosen set screw, rotate the stop collar a fraction of a turn in desired direction, tighten one of the set screws (figure 12) and rotate the tilt hand-wheel counterclockwise until it stops. Then measure the angle of saw blade with table surface, as shown in figure 11. Several trials will probably be required to produce an accurate stop at the 45-degree position.
- (5) Tighten one of the stop collar set screws securely after the adjustment has been completed.

**NOTE:** If the above adjustments have been accurately performed, the saw will now have a positive stop at "0" and "45" degrees and the pointer on tilt scale should stop at both positions.

- (6) Rotate the tilt hand-wheel until it stops at the "0" position, as indicated by the pointer.

8. Adjust Table Insert as Follows:

- a. Install the table insert by sliding it carefully into position and pressing down firmly at both ends until the spring clips on underside of insert "snap" into position. (See figure 13.)
- b. The spring clips should have enough tension to hold the table insert firmly in position in saw table. If insert is loose, lift the insert out (figure 3) and, with pliers, bend the spring clips carefully until they hold the insert securely (See figure 14.) Several trials may be required.
- c. With the table insert in place, use a small scale or straightedge to check near each of the four set screw positions, in order to determine if the table insert is even with saw table surface at all four set screw positions. (See figure 15.)

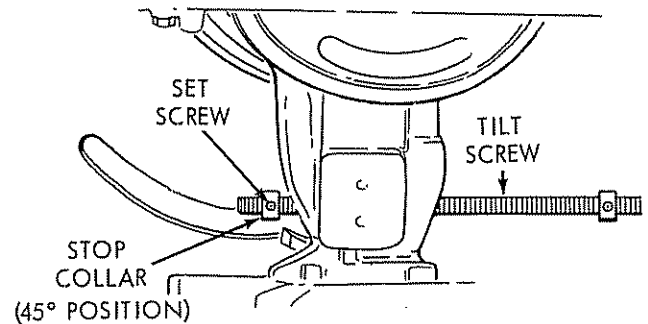

Figure 12

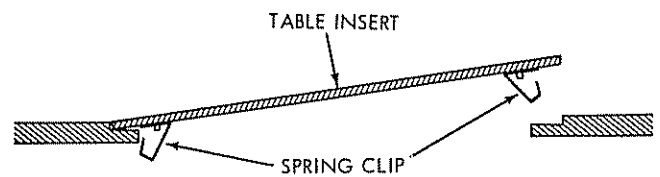

Figure 13

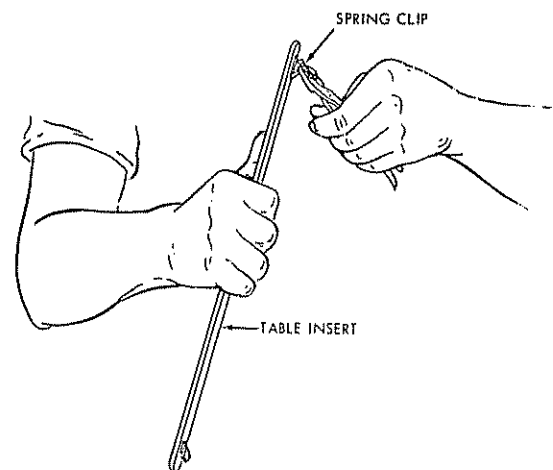

Figure 14

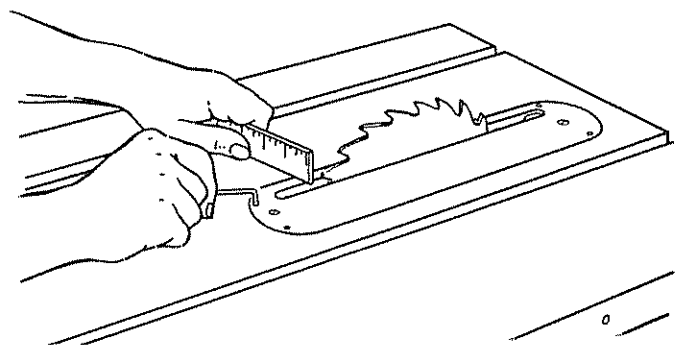

Figure 15

# assembly and adjustments

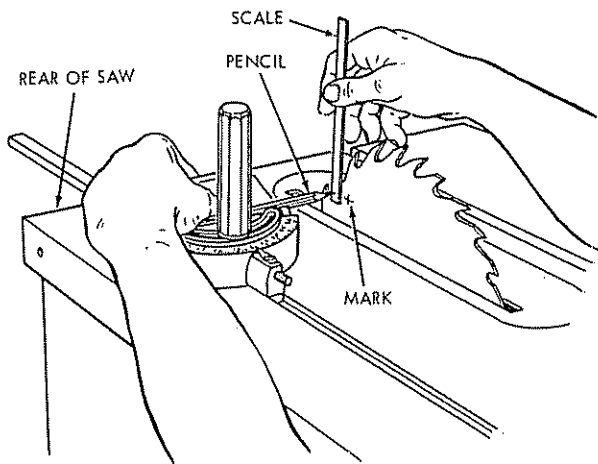

Figure 16

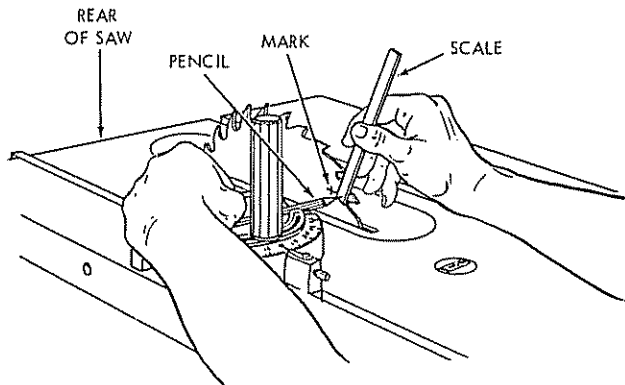

Figure 17

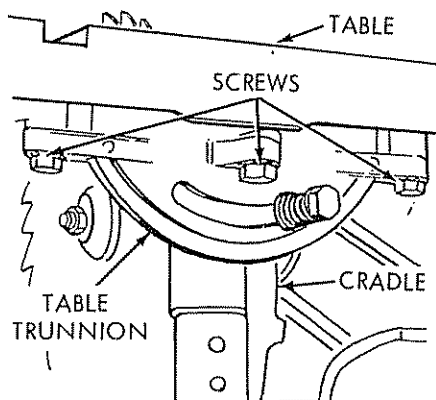

Figure 18

- d. If an adjustment is necessary, rotate each of the four set screws (or as many as required) with a 3/32-inch hex-L wrench until the surfaces are even. (See figure 15.) Make sure that ends of all four set screws are making contact with table recess by pressing on the insert at each set screw location. If the insert "rocks" when pressed at any position, adjust set screws until the "rocking" is eliminated.

## 9. Align Saw Blade With Table Grooves as Follows:

### a. Checking for Correct Alignment.

- (1) Check elevation and tilt hand-wheels to make sure each is rotated fully clockwise — to position saw blade for deepest cut and square with table top.
- (2) Make a mark at base of one saw tooth at rear of blade just above table surface. (See figure 16.) Select a tooth that is "set" toward the right-hand side of saw.
- (3) Place the miter gauge in table groove at left of saw blade. See that miter gauge is at "0".
- (4) Lay a pencil, or similar pointed tool, in the depression just ahead of miter gauge scale, with pencil point toward the blade and hold pencil in the depression with thumb of left hand as shown. (See figure 16.)
- (5) Slide the miter gauge to a position which will point the pencil at the marked saw tooth. Hold a small scale against the marked tooth and slide the pencil toward the saw until the point rests against the scale. With the left thumb, hold the pencil securely in miter gauge head. **It must not move.**
- (6) With the right hand, remove the scale and rotate the saw blade until the marked tooth is just above the saw table at the front. (See figure 17.)
- (7) Slide the miter gauge toward the front of saw table until the pencil is pointing toward the marked tooth. Insert the scale between pencil point and blade, as shown in figure 17. If the saw is parallel to table groove, the scale will just slide into the gap between the pencil point and blade. If the scale will not enter, or is loose in the check shown in figure 17, an adjustment of the table trunnions is required.

### b. Adjusting Table Trunnions.

- (1) Locate the three screws which secure the front table trunnion and two screws that secure the rear trunnion to the saw table. (See figure 18.) Loosen these screws just enough to permit the trunnion to "slip" when tapped with a mallet or plastic-tipped hammer. (If loosened completely, it would be almost impossible to achieve an accurate adjustment.)
- (2) Shift the two trunnions by tapping them lightly until the two measurements described in the preceding instructions are equal. Tighten the trun-



nion screws and recheck measurements to make sure tightening screws did not alter the setting. Several trials may be required to produce an accurate setting.

#### 10. Install the Table Rack.

- Position the table rack against lower edge of fence guide bar so that rack teeth are on upper edge of rack and pointing outward. Align the three holes in both parts. (See figures 19 and 20.)
- Insert one of the three 1/4-20 x 2-inch screws through holes at one end of rack and guide bar and place a guide bar spacer on the end of the screw. (See figure 19.) Insert the screw through the saw table and install a 1/4-inch lockwasher and 1/4-20 hex nut. Do not tighten the screw at this time.
- Install the remaining two screws, spacers, lockwashers and nuts. Rotate these three screws into their nuts until they are snug. Do not tighten them at this time.

#### 11. Check and Adjust the Rip Fence as Follows:

Your Craftsman Rip Fence has been designed to provide accuracy, reliability and long life. In order for your fence to work properly, it is imperative that it be adjusted accurately. The fence is adjusted at the factory, but due to shipping hazards, and slight tolerance buildup between individual saws, it is sometimes necessary that your fence be adjusted to your particular saw. Therefore, check your fence and adjust it (if necessary) as outlined in the instructions that follow:

**CAUTION:** It is imperative that these instructions be followed precisely, as an incorrect adjustment could damage the fence and the fence guide bar attached to your saw.

##### a. Installation of Rip Fence.

- Raise the lock handle and position the rip fence on the saw table. Do not latch the lock handle. Lower the saw blade beneath the table surface by rotating the elevation hand-wheel counter-clockwise.
- Slide the rip fence along the guide bar while watching the clearance between lower edge of fence and table top. If any portion of the fence (except sliding pad at rear) drags on the table top, or if clearance between fence and table top varies appreciably as the fence is moved, the guide bar must be adjusted. This is accomplished by tapping the guide bar slightly up or down with a soft mallet until a consistent clearance exists over entire top surface of the table. The screw holes in guide bar and table have sufficient clearance around the attaching screws to permit this adjustment.
- Tighten the 1/4-20 x 2-inch screws securely and recheck to make sure tightening these screws did not affect the guide bar setting.

##### b. Adjusting Pinion to Rack.

- Check for correct engagement (mesh) of teeth on fence adjusting shaft pinion with the gear teeth in lower edge of rack (See figure 21.) The pinion should be adjusted up or down so that

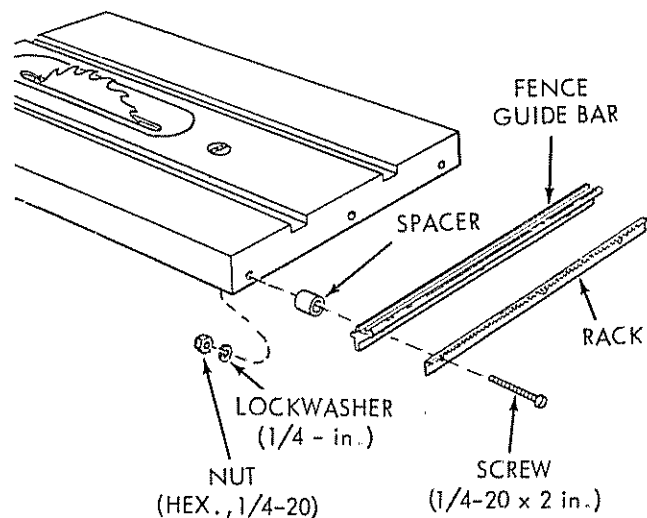

Figure 19

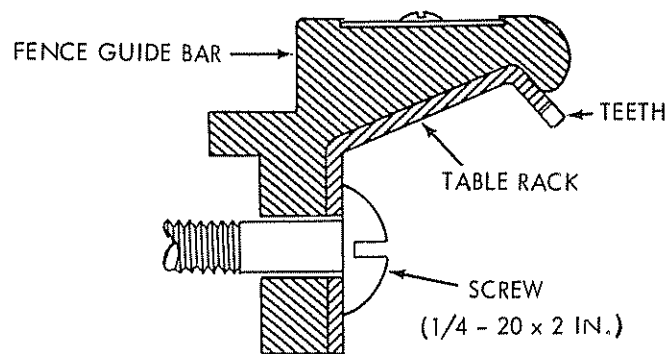

Figure 20

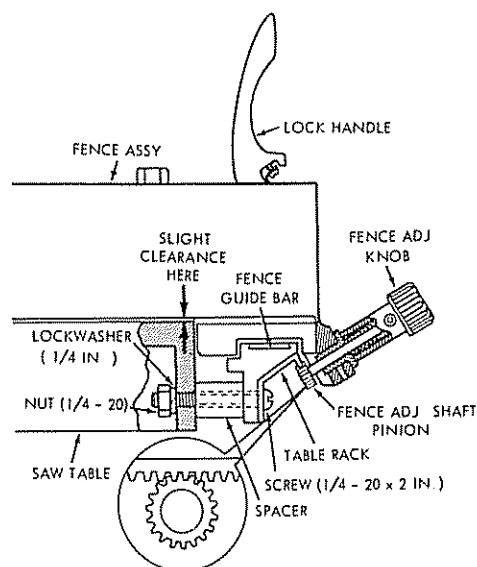

Figure 21

# assembly and adjustments

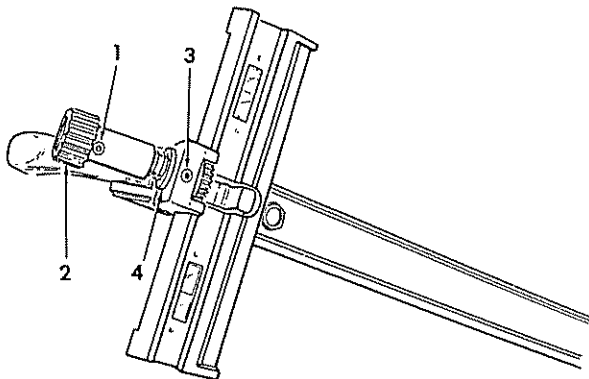

Figure 22

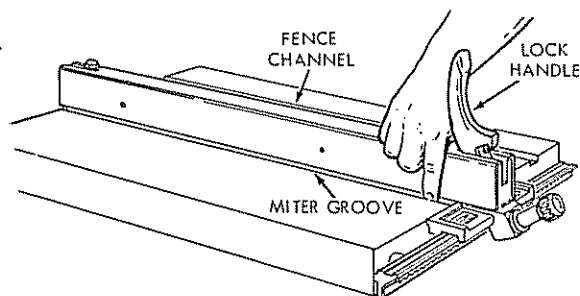

Figure 23

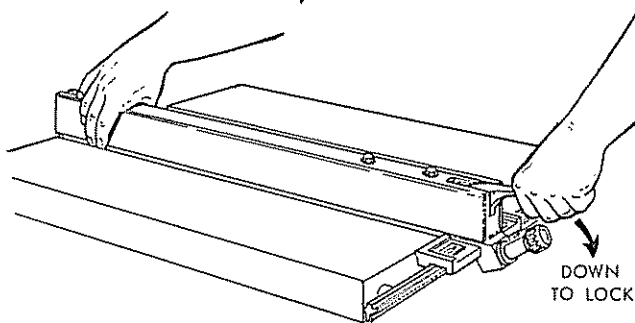

Figure 24

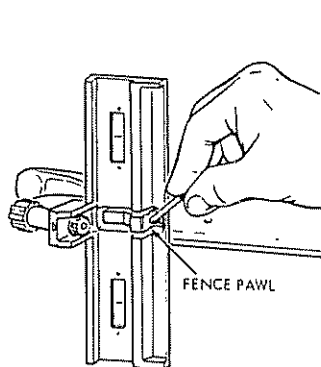

Figure 25

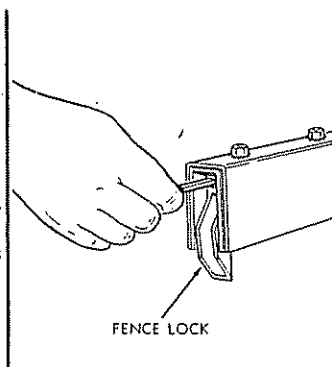

Figure 26

gear teeth are in full contact lengthwise and meshed as far as possible, just short of binding. This adjustment is made as follows: Push the fence adjusting knob all the way down, and look underneath the rack to determine if the pinion and rack teeth are aligned. (See figure 21.) If the pinion extends too far (or not far enough) loosen the set screw (1, figure 22) with a 5/32-inch hex-L wrench and slide the knob assembly on the pinion shaft (up or down) to achieve proper alignment. Tighten the set screw (1, figure 22).

- (2) Adjust gear mesh (depth of tooth contact) by loosening the set screw (3, figure 22) with a 5/32-inch hex-L wrench and rotate the eccentric (4, figure 22) until proper mesh is obtained. Tighten the set screw after adjusting. Check for proper operation at various points along the rack.

## c. Checking for Parallelism of Rip Fence with Table Groove.

- (1) With the lock handle released (not latched), slide the fence on the saw table so the front end of the channel is flush with the side of one of the two miter grooves. (See figure 23.) This can be checked by using your fingers as shown to "feel" for correct alignment. Shift the rear of the fence to the right or left slightly, causing fence not to be square with the front edge of the table, nor parallel to the miter groove.
- (2) Push down on the lock handle carefully (do not force) while watching the rear of the fence for its correcting action.

**CAUTION:** Do not force the lock handle. If the handle does not lock down readily, an adjustment is necessary — and to force it could cause damage to both the fence and guide bar.

- (3) The lock handle should lock in the down position. Do not force the handle, as it is not necessary for the handle to be all the way down to lock the fence. (See figure 24.) The rear of the fence should move to correct itself, and do so parallel (flush) with the miter groove in saw table throughout its full length. Alignment may be checked with the forefingers to determine if the fence is flush with the side of miter groove, as shown in figures 23 and 24.
- (4) If the lock handle responded as described above, and the fence aligned itself with the table groove at both ends, the fence is properly adjusted and no further attention is necessary. If not, perform the following adjustment routine.

## d. Adjusting the Rip Fence Parallel to Table Groove.

- (1) Remove the fence and turn it over. Then, with a 1/8-inch hex-L wrench, loosen the pawl set screw, located just behind the fence pawl, approximately two turns. (See figure 25.)
- (2) Using a 5/32-inch hex-L wrench, loosen the set screw at the rear of the fence approximately two turns. (See figure 26.) This screw is located in the fence lock just inside the channel, as shown.

- (3) Place the fence back on saw table and notice that the lock handle offers no resistance at any position.
- (4) Place the lock handle in "locked" position, and, using a 1/8-inch hex-L wrench inserted into the fence-pawl set screw from underneath the saw table, tighten the set screw finger tight. (See figure 27.) Do not use wrench or pliers — finger tight only.
- (5) Raise the lock handle, push the fence to one side (off square) at the rear. Then lock the fence with the lock handle, while watching to make sure it "corrects" itself. Repeat this operation two or more times. The fence should "correct" itself each time it is locked.
- (6) Raise the lock handle and align the fence with the miter groove (at the front end of the groove) as shown in figure 23. Push the lock handle down.
- (7) Check for correct alignment with saw table groove for the full length of the fence. If it is aligned at the front but out of alignment at the rear, loosen the two hex-head screws on top of the channel near the front (figure 28) just enough to permit the channel to slip when tapped lightly with the palm of one hand. Tap the channel at the rear of the fence with one hand until it is aligned with the table groove. Tighten the two hex-head screws securely and recheck. More than one trial may be required, as tightening the screws may change the setting slightly.
- (8) Check for "automatic correcting" by releasing the lock lever, shifting the fence off square at the rear, then locking it. The fence should square itself automatically and be flush (parallel) with the miter groove each time the handle is locked down.
- (9) Lock the fence with the lock handle, and, using a 5/32-inch hex-L wrench, tighten the fence lock set screw at the rear, hand tight only. (See figure 29.) Make sure the fence is "secure" to the table at the rear.

**NOTE:** If the fence fails to square itself every-time, check for any burr or foreign material on the surface of the fence head where it contacts the saw table. Also check for nicks or burrs in edge of saw table. Stone off any irregularities on these surfaces.

e. Aligning Rip Fence Plastic Indicators.

- (1) If for any reason the tilt hand-wheel has been rotated during preceding operations, rotate it clockwise until it stops (tilt pointer at "0").
- (2) Raise saw blade above the table surface by rotating the elevation hand-wheel clockwise.
- (3) Position the rip fence on the right-hand side of saw blade with the fence channel one inch from the saw blade and lock the fence. Be sure to use one of the teeth bent (set) to the right of blade and measure from this tooth to the fence, since this determines your width of cut. (See figure 30.) This distance should be measured accurately with a scale.

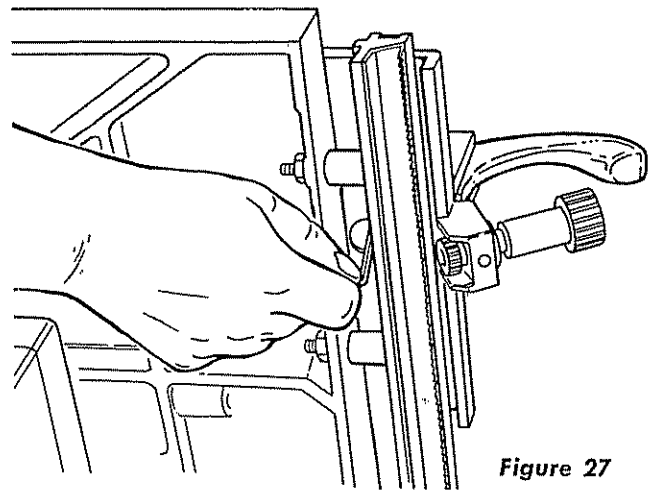

Figure 27

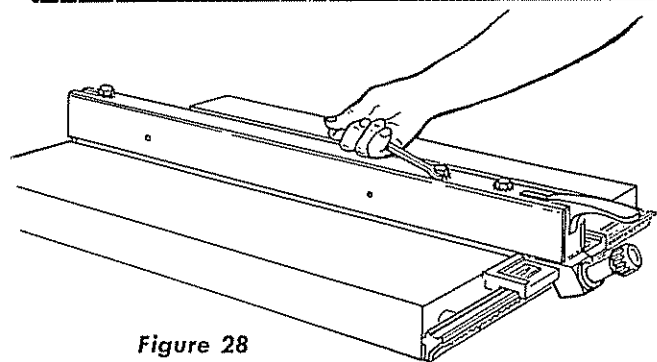

Figure 28

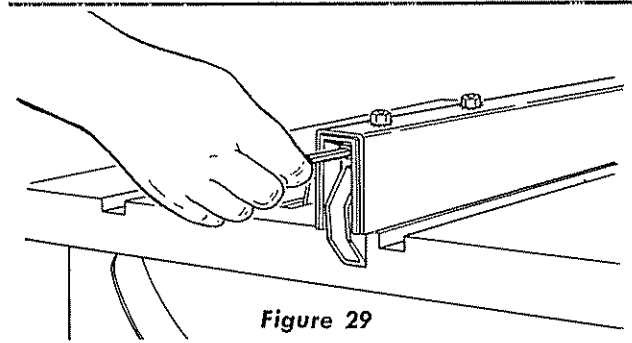

Figure 29

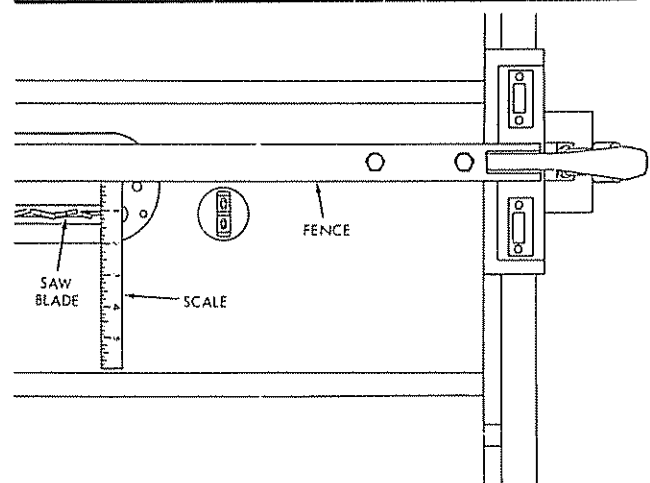

Figure 30

# assembly and adjustments

(4) Set the right-hand indicator (a scribed line in the plastic window) to "1" inch on the guide-bar scale. This is accomplished as follows:

(a) A close look will show a reflection of the indicator line on the mirror surface of the guide-bar scale. In order to make sure that

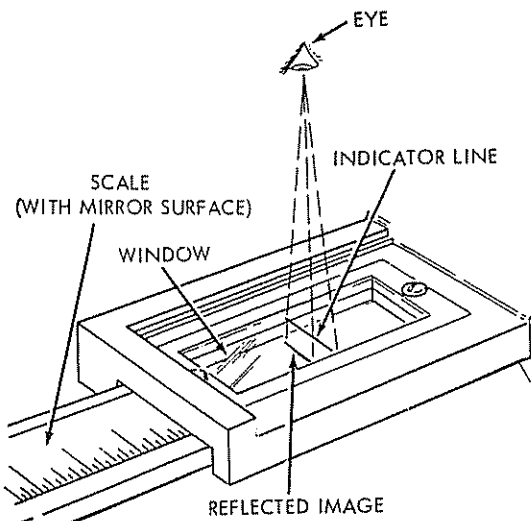

Figure 31

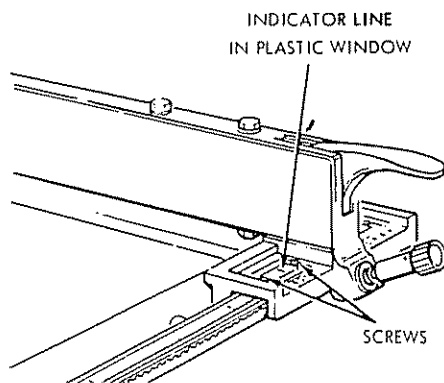

Figure 32

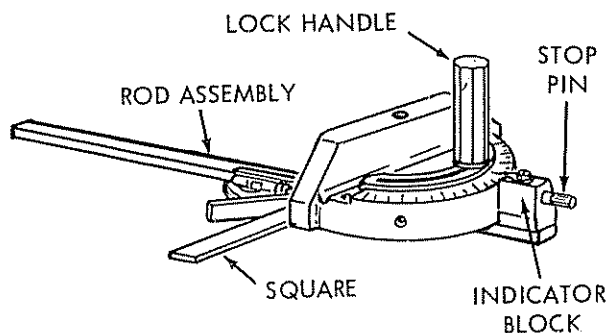

Figure 33

you are sighting squarely above the scale, move your eye until the indicator line and its reflected image coincide. (See figure 31.)

(b) If an adjustment is required, loosen the two screws (one at each end of the window) and shift the plastic window until the indicator line is aligned with the "1" inch line on the scale. (See figure 32.) Tighten the two screws and recheck for accuracy. If the plastic window cannot be shifted far enough to provide this alignment, loosen the screws that secure the guide-bar scale to the guide-bar at its ends, shift the scale slightly and tighten the screws. Then proceed to adjust the plastic window as described above.

(c) When the fence is correctly adjusted and moved to any position at the right of the saw blade, the scale will indicate the width of the desired cut. Make several trial settings and check by measuring with a scale from the fence to the blade.

**NOTE:** When properly adjusted, the indicators may be used for most operations, thus eliminating the need for actual measurements, except for extreme requirements. When sighting the indicator, always use the system shown in figure 31 in order to make sure the sight angle is correct.

(d) Move the fence to the left-hand side of saw blade and adjust the left-hand indicator (right-hand side of fence channel) in the same manner as for the right-hand indicator.

**NOTE:** Remember, if the scale must be moved when adjusting the left indicator, it will change your settings on the right-hand indicator which was previously set.

(5) Remove the rip fence from the saw to avoid interference with subsequent adjustment routines.

## 12. Check and Adjust the Miter Gauge as Follows:

The miter gauge was set at the factory. During shipment, however, rough handling might have disturbed the setting. To assure maximum accuracy the "0" (zero) degree stop should be checked and adjusted (if required) as follows:

a. Checking the Miter Gauge.

- (1) Loosen the lock handle and push stop pin firmly into the middle detent ("0" position on the scale). The stop pin will be seated more effectively if it is rotated slightly as it is being "pushed" into the detent. Tighten the lock handle firmly hand tight. (See figure 33.)
- (2) Using a combination square, check for an exact 90-degree angle between the miter gauge and rod assembly. If this measurement is exactly 90 degrees, the adjustment has not been disturbed and the gauge is ready for use. If not accurate at 90 degrees, adjust the gauge as follows:

b. Adjusting the Miter Gauge.

- (1) Loosen the lock handle, disengage stop pin, hold the square solidly against the rod assembly and face and tighten the lock handle firmly by hand. Always tighten the lock handle hand tight only. Do not use a wrench or pliers.
- (2) Recheck to make sure that tightening the lock handle did not alter the setting. Remove the square from the gauge.
- (3) Loosen the two screws that attach the indicator block to the rod assembly. Shift the indicator block until the stop can be pushed solidly into its detent. Hold the indicator block aligned with the rod assembly and the stop pin seated firmly in the detent and tighten the two screws.
- (4) Loosen the lock handle and recheck for accuracy with the combination square. (Make certain the stop pin is fully seated.) Tighten the lock handle and readjust if necessary.
- (5) After completing the above adjustment, loosen the pointer attaching screw, set pointer at "0" (zero) and tighten the screw.

**NOTE:** Detents at the two 45-degree positions are jig bored. When the gauge is adjusted for 90-degree cut, the 45-degree positions are correct.

- (6) Remove the miter gauge from saw table until remaining checks have been completed.

13. Install Saw Guard Assembly as Follows:

a. Installing Splitter Blade Bracket.

- (1) Install the two 5/16-18 x 5/8-inch, hex-head screws loosely in holes at rear of saw cradle as these screws cannot be installed after attaching the splitter blade bracket. (See figure 34.) These are the screws that secure the motor support in the cradle.
- (2) Install the splitter blade bracket with two 5/16-18 x 1 inch hex-head screws. Tighten screws finger tight at this time.
- (3) Refer to figure 35 and hold the splitter rod to the left of splitter support. Rotate the splitter rod so the "flat" on the rod is toward the operator. Then slide the splitter rod into the splitter support from the left until the pin (through the rod) bottoms in the slots in splitter support. (See figure 35.) Tighten the thumb screw firmly against the "flat" of splitter rod.
- (4) Slide the splitter rod (attached to splitter support) into the splitter blade bracket until the splitter blade is directly behind the saw blade. (See figure 36.) Do not be concerned if the splitter bar does not align vertically as this will be corrected in the next step. Tighten the socket-head set screw in splitter blade bracket with a 5/32-inch hex-L wrench.

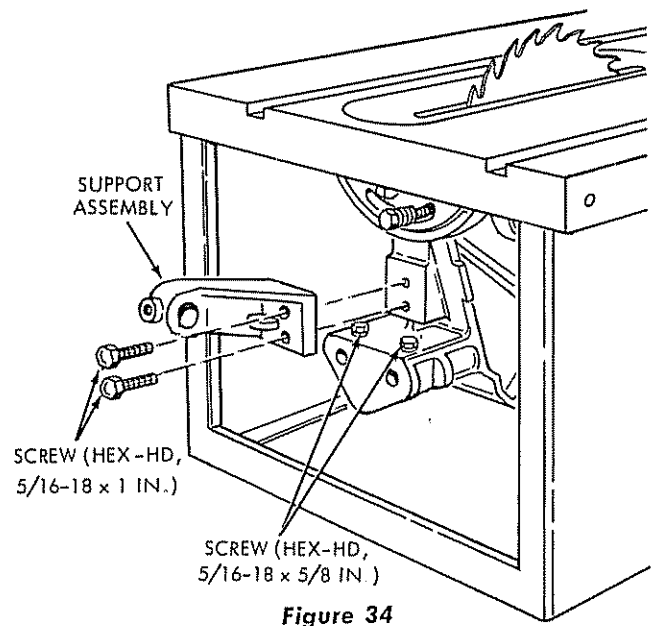

Figure 34

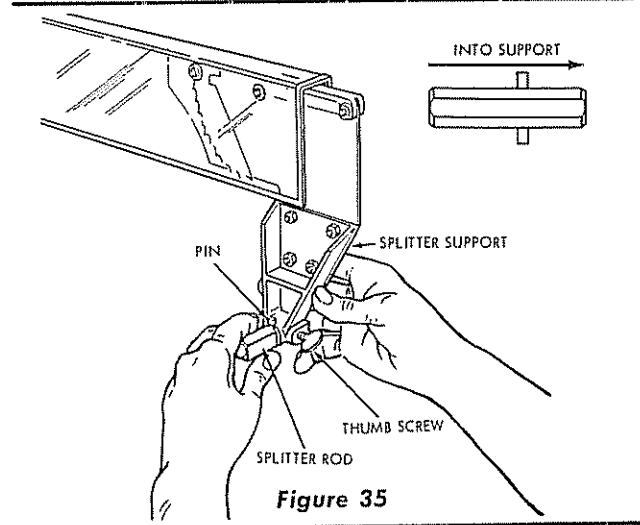

Figure 35

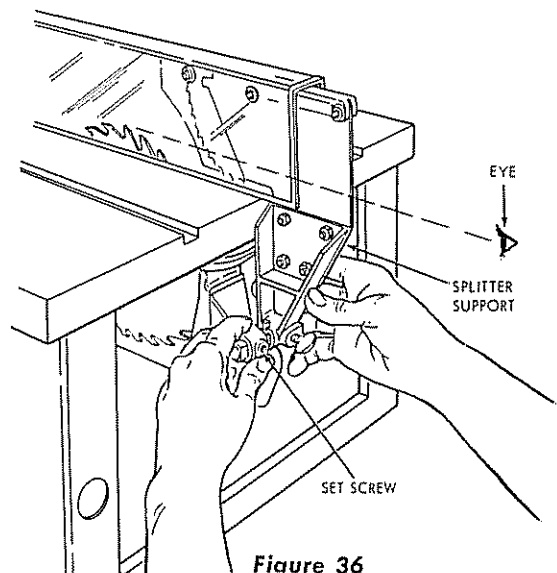

Figure 36

# motor specifications and mounting

- (5) Grasp the splitter blade with both hands, as shown in figure 37, and by sighting along the splitter blade and saw blade, align the splitter blade vertically with saw blade. Tighten the two 5/16-18 x 1-inch screws to secure the splitter blade bracket to saw cradle. This adjustment may leave the splitter blade slightly to the right or left instead of directly behind the saw blade. If so, loosen the socket-head set screw (figure 36) and slide the splitter support carefully to the left or right until the splitter blade is directly behind the saw blade. It may be necessary to perform the preceding splitter blade alignment alternately several times until perfect alignment is attained.

- (6) Recheck to make sure the following screws are tight:

The socket-head set screw (figure 36) that secures the splitter rod, and the two hex-head

screws (figure 37) that attach the splitter blade bracket to saw cradle. Sight along splitter bar and saw blade again after tightening these screws to make sure alignment was not disturbed.

**NOTE:** After the splitter blade is properly aligned, always remove the guard by loosening the thumb screw (figure 35) and sliding the assembly off the splitter rod. This will avoid upsetting any of the alignment adjustments, as the pin in the splitter rod will serve as a "stop" when the guard is installed.

**CAUTION:** When cleaning the plastic guard is necessary, wipe surfaces with a clean, dry cloth. Do not use solvent of any kind.

## MOTOR SPECIFICATIONS & MOUNTING

1. This Craftsman Saw is designed for use with a 3450 rpm motor. The saw arbor has a 2-1/2-inch diameter pulley attached and a 2-1/2-inch diameter motor pulley is supplied for driving the saw at the proper speed of 3450 rpm through a 1 to 1 motor to saw ratio.

**CAUTION:** Do not install a larger diameter pulley on the motor as it would drive the saw blade at speeds which would be dangerous. The following Craftsman motors are recommended, available at any Sears Retail Store or Catalog Order House:

Catalog No.	RPM	Horsepower	Volts
99KT1217C	3450	1	110-120
99KT1220C	3450	1	110-120 or 230
99KT1221C	3450	1-1/2	110-120 or 230

2. The belt guard, supplied with the saw for safety protection, will fit any of the above recommended motors. It is not recommended that a motor be used having a configuration that will not permit installation of the belt guard.
3. The Craftsman motors recommended in the preceding table may be connected for either right- or left-hand rotation. Make sure that wiring connections are made so the motor shaft will rotate in a clockwise direction (when facing the drive end). (See figure 38.)

### 4. Attach the Motor to Motor Base as Follows:

- Position the motor with the 5/8-inch diameter shaft at the right with mounting base in a vertical position. (See figure 39.)
- Position the motor support assembly as it would be oriented if mounted on the saw cradle, with the motor base against the motor mounting base.
- Insert four 5/16-18 x 3/4-inch carriage bolts (from loose parts package) through the motor base and motor mounting base (See figure 39.)
- Install an 11/32-inch flat washer, 5/16-inch lock-

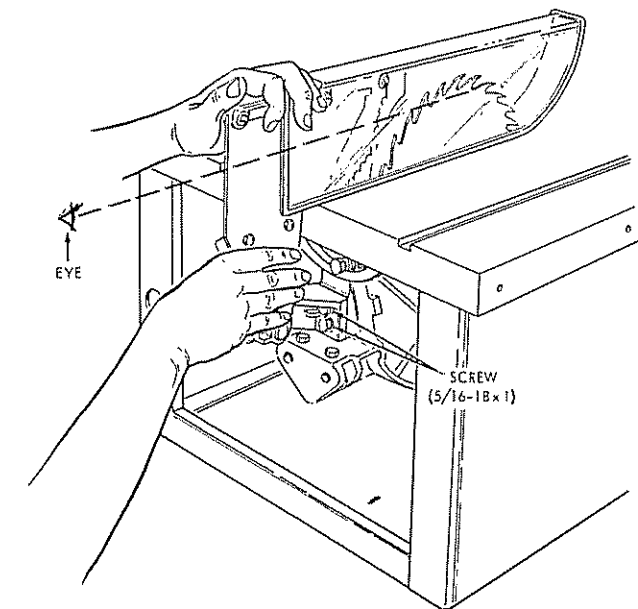

Figure 37

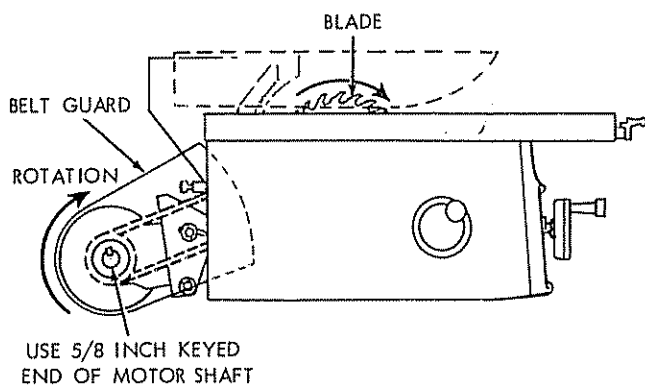

Figure 38

washer and 5/16-18 square nut on each carriage bolt finger tight. (All parts are in loose parts package.)

- e. Shift the motor mounting base on motor base until the top edges of each are even and carriage bolts are approximately centered in the slotted holes of the motor base.
- f. Tighten the four square nuts securely.
- g. Install shaft guard on left-hand end (1/2-inch diameter) motor shaft, if not already in place. This guard is supplied with the motor.

## 5. Install Motor and Support Assembly.

- a. Position the blade slightly below the deepest cut position and tilt pointer at "0".
- b. Install the motor pulley on motor shaft with the set screw boss toward the outside. (See figure 39.) Do not tighten the set screw at this time.
- c. Place the drive belt over the saw arbor pulley by reaching inside saw base, allowing it to hang temporarily on this pulley.
- d. Slide the two pins on motor support assembly into their holes in saw cradle far enough to enable the belt to be placed in the groove of motor pulley. Raise blade to deepest cut position.
- e. Grasp the motor with both hands as shown in figure 40 and lift up until the pivot arm screw is at the rear of the slot, as shown. While holding the motor in this position pull it rearward (toward operator) until the drive belt is "snug" and tighten the two motor mount clamp screws securely. The pivot arm screw should still be at the rear of limit of its slot.
- f. Release the motor and note that it remains at essentially the same position as it was held. The motor base will probably rotate slightly rearward, thus leaving the pivot arm screw slightly away from the end of its slot.
- g. If the belt is not aligned with the two pulleys, which can be readily seen by sighting along edges of both pulleys, slide the motor pulley in or out on the shaft as required and, when correctly aligned, tighten pulley set screw with a 5/32-inch hex-L wrench. (See figure 41.)

**NOTE:** If correct pulley alignment cannot be obtained by the preceding method, loosen the square nuts on motor base, shift the motor in desired direction and tighten the nuts.

- h. Lower the blade enough to permit removal of drive belt from the arbor pulley and remove the belt in preparation for installing the belt guard.

## 6. Install Belt Guard.

- a. Place the guard clamp ring around right-hand end of motor, slide the free end into the screw-type fastener. (See figure 42.) While holding the two ends together, rotate the screw in fastener with a screw-

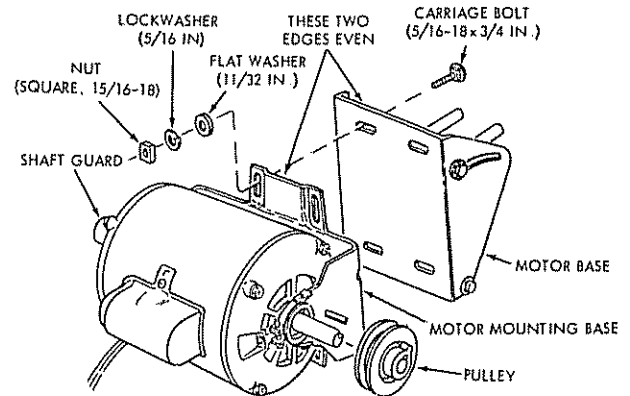

Figure 39

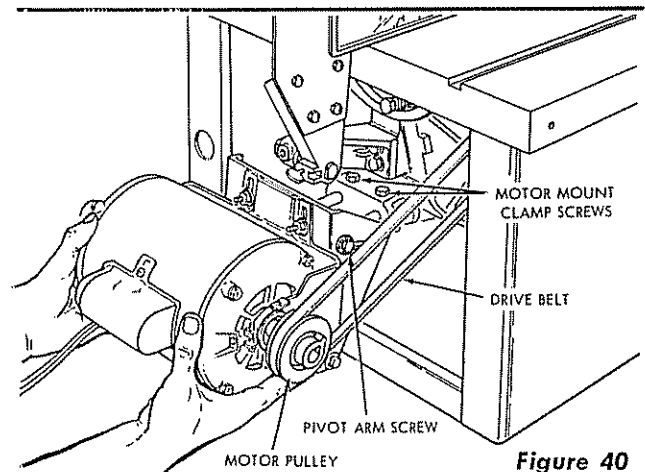

Figure 40

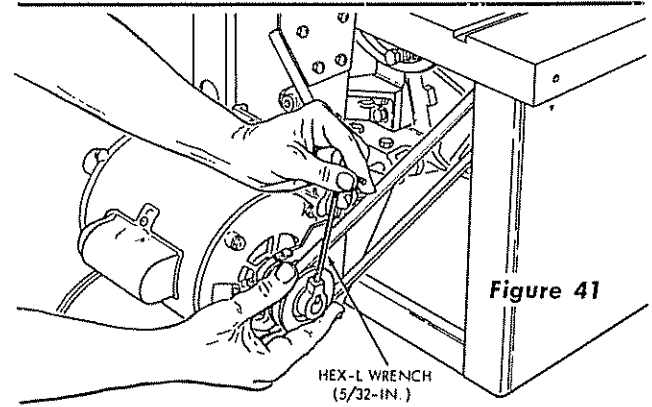

Figure 41

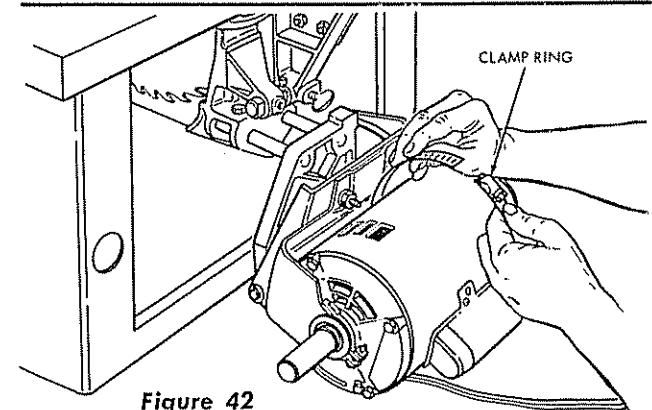

Figure 42

# motor specifications and mounting

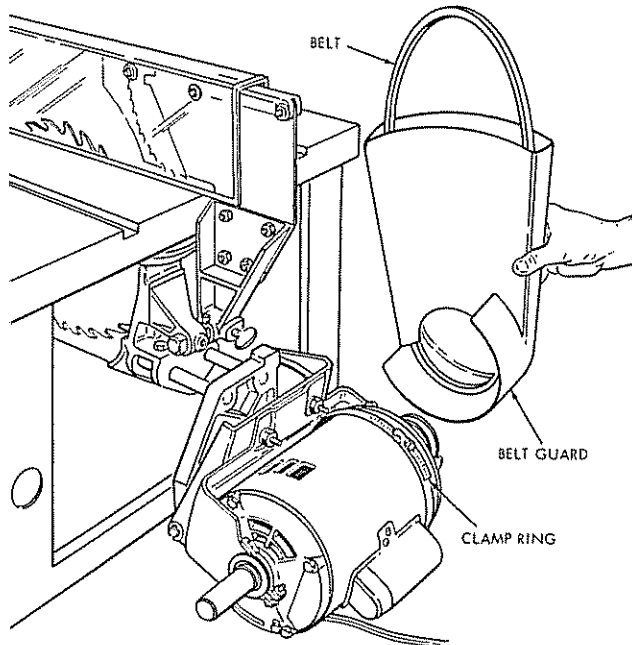

Figure 43

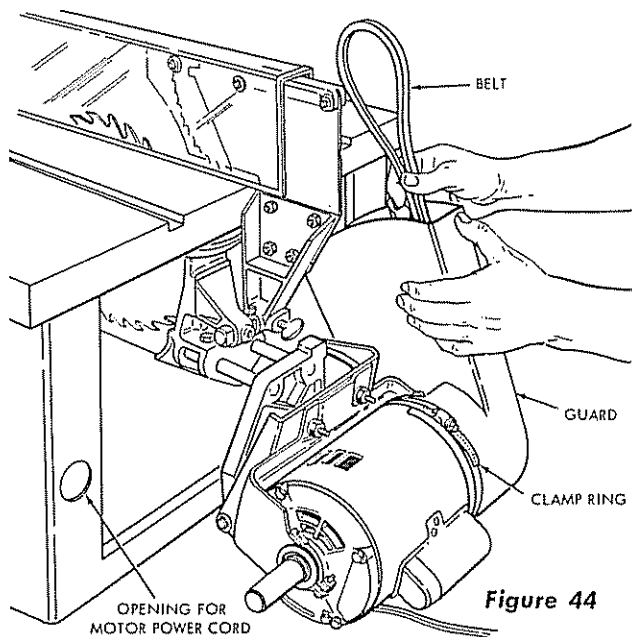

Figure 44

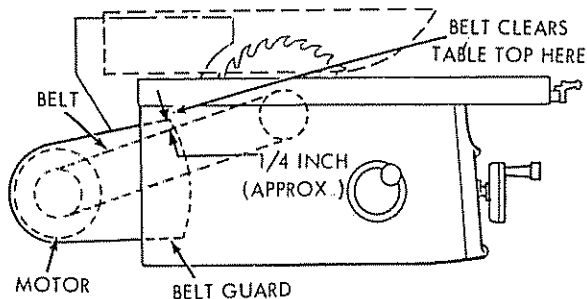

Figure 45

driver. Make sure the screw engages the openings in the ring and rotate the screw until the clamp ring diameter just leaves enough clearance on motor frame for the guard to be slipped easily under the ring.

- b. Hold the belt guard as shown in figure 43 and insert the drive belt into the guard as shown. The lower end of belt should contact the inner wall of the guard so it will pass over the motor pulley when the guard is slipped into place.
- c. Slide the guard on end of motor, while holding it as shown in figure 44, and slide the clamp ring over the edge of guard leaving edge of ring approximately 1/2-inch from edge of guard. Do not tighten the clamp ring at this time.
- d. Grasp the belt between thumb and forefinger as shown in figure 44 and, while looking down into the guard "hook" the lower loop of belt onto the motor pulley. Shift the guard on motor to center the belt in the guard.
- e. Continue to hold the belt on motor pulley, rotate the guard downward and "hook" upper end of belt onto the saw pulley inside the base.
- f. Rotate the elevation hand-wheel clockwise until it stops, to place the saw blade in its highest position.
- g. Position the belt guard so the belt clears the inside of the guard at the upper position approximately 1/4-inch and the guard does not touch the underside of saw table. (See figure 45.) Correct positioning of the belt guard is important. If the belt should be permitted to rub against the guard it would soon wear a slot in the guard.
- h. Tighten the clamp ring to hold the guard securely on motor.
- i. Rotate the elevation hand-wheel counterclockwise to lower the saw blade to the lowest position and check position of guard. The belt should still clear the inside of the guard.

## 7. Adjusting Pivot Arm Screw.

This adjustment (figure 46) is necessary to prevent motor vibration (screw too loose) and to permit the motor mount to maintain correct belt tension whenever the saw blade is raised or lowered with the elevation hand-wheel (screw too tight if belt tension is not maintained). When either of these conditions are evident, adjust the screw as follows:

**CAUTION:** Do not tighten the pivot arm screw to a locked position, as it would be sheared off when the saw blade is raised.

- a. Tightening or loosening the pivot arm screw (figure 46) should produce conditions described above. The head of pivot arm screw (figure 46) applies force on a spring washer which bears against a flat steel washer and in turn permits the motor base to slide inward or outward with proper tension.



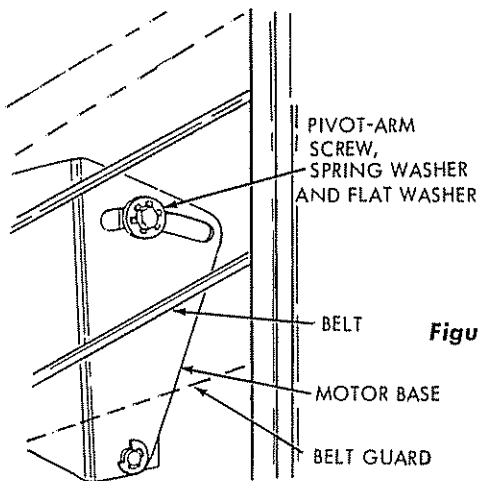

Figure 46

- b. Apply a few drops of oil (SAE 10 or 20) to the flat washer and in slot in motor base, and adjust the screw in small increments until the motor base slides readily in or out in response to blade elevation movement throughout the full range.
- c. After obtaining normal movement of motor base, observe the saw in operation after starting it as described in subsequent instruction. If the motor base tends to vibrate, tighten the screw a little at a time until vibration is minimized. After eliminating vibration recheck as in preceding step b, to make sure the base will still slip in response to blade elevation movements.

**8. Connect and Position Motor Power Cord.**

- a. Feed the motor power cord through the large hole in saw base. (See figure 44.)
- b. Grasp the connector on end of motor power cord and, while looking into the base, insert the plug into the receptacle at rear of switch box. (See figure 47.)
- c. Position the power cord as shown in figure 47, and install two cord retaining clips on edge of saw base flange to secure the cord. Locate clips at approximate positions shown. Allow approximately 12 inches of cord between the motor and saw base.
- d. Hold the power cord and slide the grommet (on cord) up to the base and insert it into the hole in base panel. (See figure 48.)

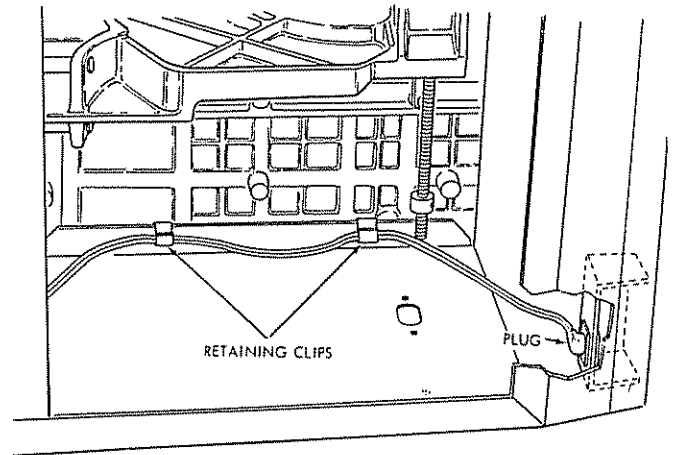

Figure 47

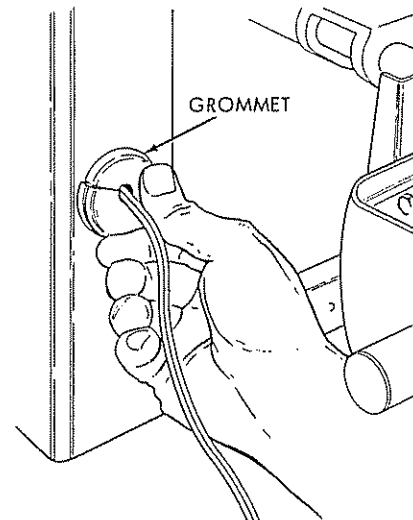

Figure 48

**MOUNTING SAW ON BENCH**

Some users prefer to mount the saw solidly by bolting it to a bench or table top. The following method for mounting the saw is recommended.

**CAUTION:** Make sure the saw mounting surface of bench or table is even and free of "twist" in order to prevent distortion of saw table when mounting bolts are tightened.

1. Select a sturdy table or bench and plan the saw location for convenience and accessibility.
2. Measure and mark the two hole locations in bench (or table), using the dimensions shown in figure 49. (Dimensions are given from hole centers.)

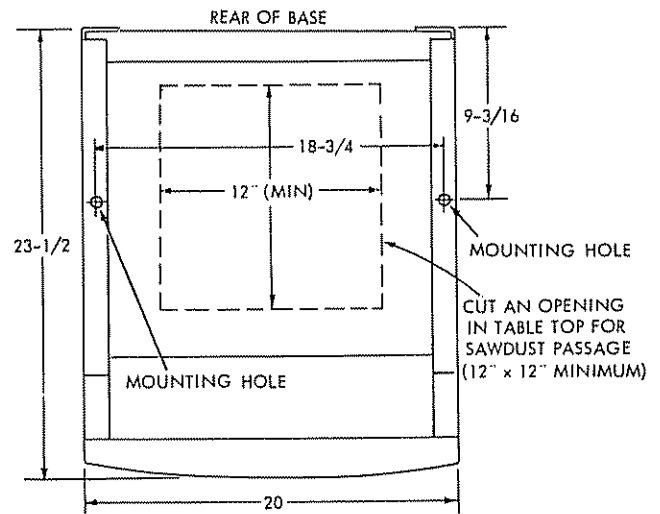

Figure 49

# motor specifications and mounting

3. Drill two holes in table at marked locations. Holes in saw base are 7/16-inch in diameter. It is recommended that 3/8-inch bolts be used for mounting.
4. Cut an opening in the table top under saw base, in order to prevent accumulation of sawdust inside the base. The opening should be at least 12-inches. The actual size will depend upon the type of table or bench being used.
5. Mount the saw with proper length bolts.

## PERIODIC MAINTENANCE OPERATIONS

This Craftsman saw is a fine machine and should be given the best of care. If kept clean and properly lubricated, it will provide many years of trouble-free service. There are no specific maintenance time tables. However, operations listed and described in paragraphs immediately following should be performed when conditions or symptoms suggest need for attention.

### 1. Removing Saw Blade.

**NOTE:** The saw blade, regardless of type being used, should be kept sharp at all times.

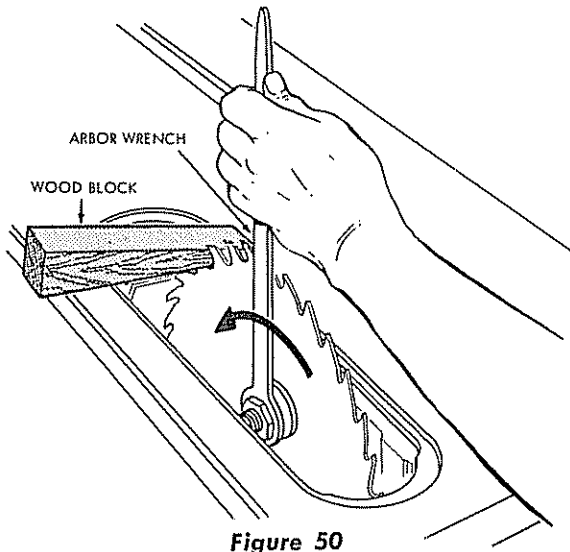

Figure 50

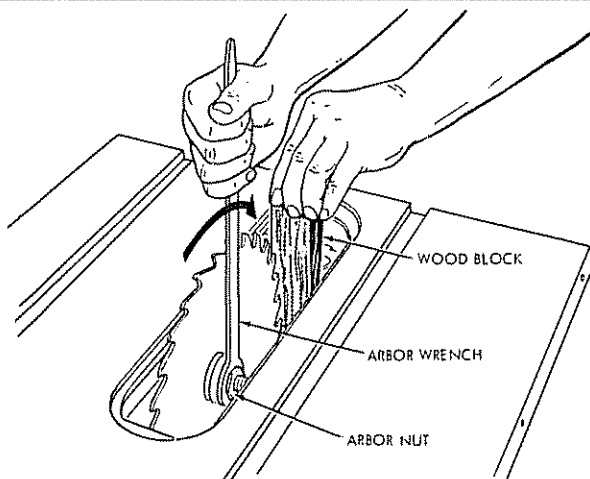

Figure 51

- Accurate and effective work cannot be achieved with a dull blade. The saw arbor has right-hand threads which causes the arbor nut to become tighter in response to saw rotation.
- a. Remove the table insert, as described under "Assembly and Adjustments".
  - b. Slide a wedge shaped block of wood under a saw tooth to wedge the blade and prevent rotation. (See figure 50.)
  - c. Using the arbor wrench supplied with the saw, rotate the arbor nut counterclockwise to loosen it. Remove the nut and loose collar with fingers.
  - d. Remove the wood block and slide saw blade off the arbor shaft.

### 2. Installing Saw Blade.

**CAUTION:** Under no circumstances should a blade with a diameter greater than 10 inches be used with this saw.

- a. Slide the new blade on arbor shaft, making sure saw teeth are "pointing" toward the front of saw table. Install the loose collar and arbor nut finger tight.
- b. Insert the wedge shaped wood block into the table opening at the rear of saw blade and tighten the arbor nut with the arbor wrench supplied with the saw. (See figure 51.) Remove the wood block.
- c. Install the table insert as described under "Assembly and Adjustments".

### 3. Lubricate Saw When Needed.

Lubricant should be applied to friction points when they appear dry upon visual inspection, or when friction increases on the various controls.

Refer to the "Repair Parts" exploded views and "Parts List" for correct item names.

- a. The tilt and lift screws are self-cleaning, which prevents clogging or gumming of the threads, as the sharp threads wipe and clean the gear teeth. Apply a few drops of SAE 20 or 30 oil as needed to keep parts rotating smoothly.
- b. The saw arbor bearings have been packed at the factory with proper lubricant and require no additional lubrication. Other parts requiring lubrication should be oiled frequently with SAE No. 20 or 30 oil. The following parts should be lubricated regularly:
  - (1) Table trunnions.
  - (2) Lift screw and gear rack of assembled arbor.
  - (3) Tilt screw block, tilt screw threads and tilt nut.
  - (4) Pivot pin and saw arbor housing guide.
  - (5) Clamp screw.
- c. All points where a slip fit is necessary for adjustment purposes should be oiled occasionally. (Pivot arm screw, for example, figure 46.)
- d. Attention should be given to moving parts in the rip fence and miter gauge for cleanliness and lubrication.

# operating controls

- e. To prevent the saw table surface from rusting, it should be kept covered with a film of Sears "Stop Rust" when not in use. It can be wiped off with a cloth before using. Treat other unplated and unpainted parts and surfaces with "Stop Rust".

## OPERATING CONTROLS

Before operating the saw, the operator should examine all controls until thoroughly familiar with their functions, as well as making sure that mechanisms respond to operation of controls. (See figure 52.)

1. **Elevation Hand-Wheel** — located on the front of the saw to raise or lower the saw blade.
2. **Tilt Hand-Wheel** — located on left-hand side of saw to control the angle of tilt. The saw blade can be tilted from 0 to 45 degrees, as indicated on the Tilt Scale. If the angle of cut (tilt) must be extremely accurate, the angle of the saw blade should be checked with a protractor, or with a board known to be cut at the exact angle required.
3. **Rip Fence** — the fence is operated by pushing in the Fence Knob so that it engages a pinion gear with the teeth on the Rack. Turning the knob after pushing it in will cause the rip fence to move across the table. When the knob is released, it becomes disengaged from the pinion gear and the rip fence can be moved across the table by hand. Keep the saw table and rip fence clean, as dirt may prevent the rip fence from assuming proper alignment when tightened.
4. **Lock Handle** — this handle is used to clamp the rip fence in place after it has been moved to the desired position.
5. **Miter Gauge** — this gauge is used in table grooves as a guide for the work-piece. The angle of the gauge can be adjusted by loosening the clamp handle and positioning the gauge as indicated by the dial and pointer on the gauge.
6. **Key** — located at lower right of saw base, alongside the ON-OFF switch, to lock the switch and prevent unauthorized persons turning on the saw. The key must be in the lock before the ON-OFF switch can be turned on. (See figure 53.)
7. **ON-OFF Switch** — also at lower right of saw base. The switch lever is of unique design for maximum safety protection. It is turned "on" by inserting the forefinger under end of lever and pulling it outward. (See figure 54.)

The switch can be turned off by thumb pressure (figure 55) or by striking it with any part of the body.

**NOTE:** At this point, plug in the power cord, insert the key and turn it to the unlocked position and pull the ON-OFF switch lever out to start the saw (figure 54.) Turn off the ON-OFF switch by pressing the lever inward (figure 55) to stop the saw.

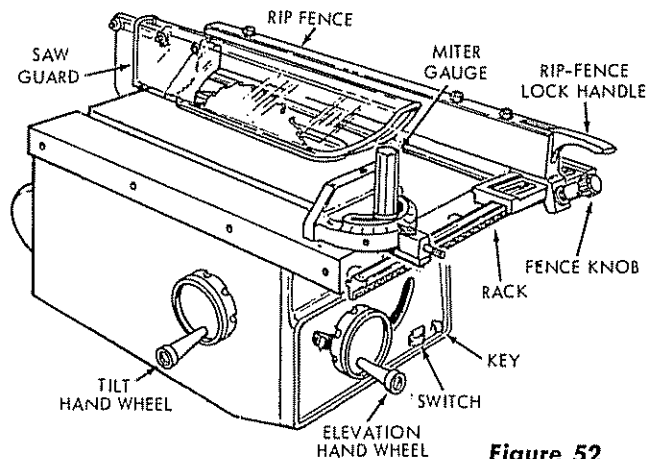

Figure 52

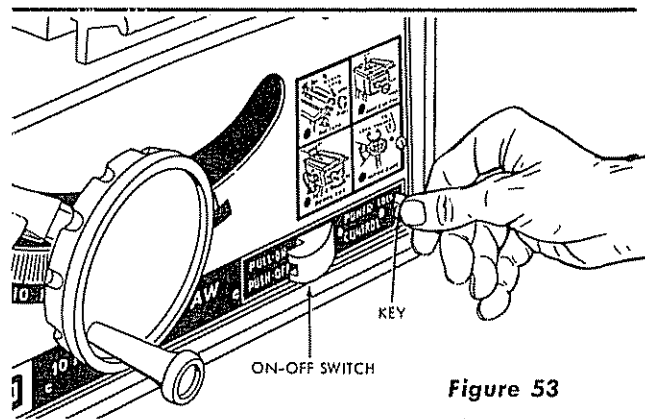

Figure 53

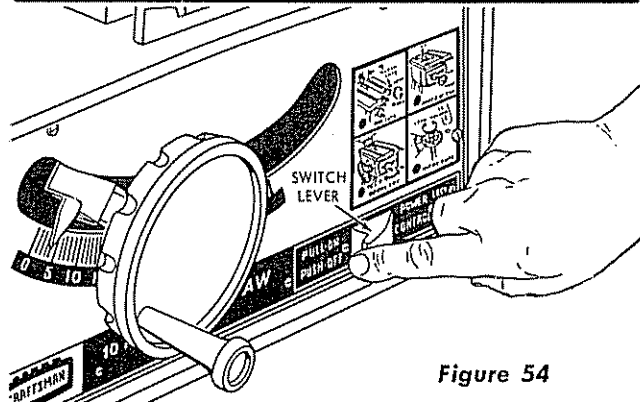

Figure 54

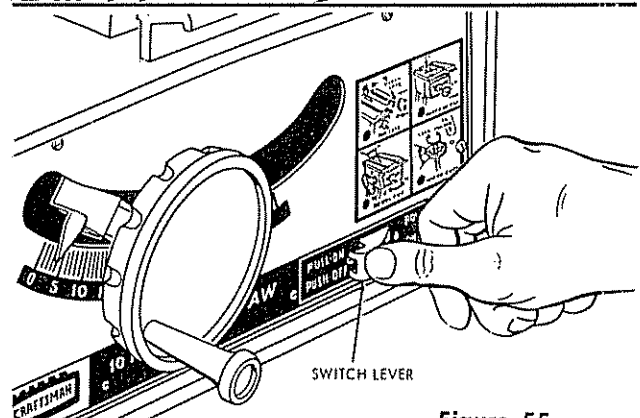

Figure 55

# proper operating procedures

## PROPER OPERATING PROCEDURES

### COLOR CODED CONTROLS

In order to simplify operation of this bench saw, basic set-up and operating adjustments are keyed to the controls to be used in performing the operation with color discs applied directly to the item involved. These set-up adjustments and color-codes are illustrated on the front (trim) panel of the saw. The colors and operations to which they are keyed are as follows: (See figure 56.)

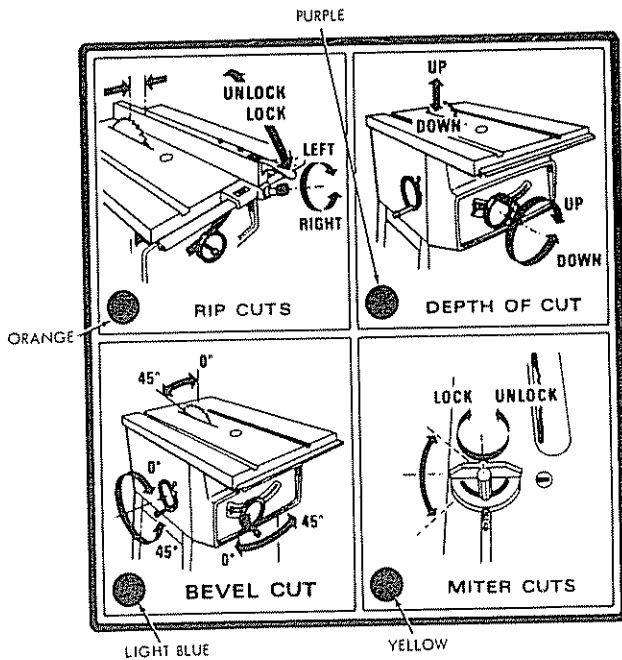

Figure 56

1. **ORANGE** — Rip Cuts. An orange disc is located in the end of fence locating knob. This knob is used for positioning the fence (with lock handle released) for the desired width of board when ripping.
2. **PURPLE** — Depth of Cut. A purple disc is located in the end of the handle attached to the elevation hand-wheel. Rotation of the elevation hand-wheel raises or lowers the saw blade to provide the desired depth of cut.
3. **LIGHT BLUE** — Bevel Cut. A light blue disc is located in the end of the handle attached to the tilt hand-wheel. Rotation of the tilt hand-wheel positions the saw blade at the desired angle with saw table for the bevel cut required. The angle is indicated by the pointer on the tilt scale (located on front panel).
4. **YELLOW** — Miter Cuts. The miter gauge indicator (pointer) is colored yellow. The pointer and miter gauge scale are used for setting the gauge to produce the desired miter cut angle.

**NOTE:** For additional descriptions of controls involved in the use of the saw, refer to the paragraph "OPERATING CONTROLS".

### CHECK AND ADJUST THE EXACT-I-CUT INDICATOR:

**NOTE:** This adjustment is listed at this point since it is necessary to operate the saw in order to make the test.

The cut indicator ("Exact-I-Cut") located a few inches ahead of the saw blade (figure 57), enables the operator to determine precisely where the cut in a particular board will occur, provided the cut indicator shoes have been correctly positioned. It should be checked and adjusted (if necessary) as follows:

1. Inspect the cut indicator housing (figure 58) to make sure it is even or just slightly below the level of table top surface. If too high, locate the two cut indicator housing attaching screws underneath the saw table and tighten them until the housing is flush (or slightly below) the table top surface. If the cut indicator housing is too low, loosen the attaching screws until it is correctly positioned. (The cut indicator housing has a spring-type washer under it which permits it to be raised, or lowered, in response to tightening or loosening the attaching screws.
2. Position the saw blade in the 90° position (0° on tilt scale), by rotating the tilt crank counterclockwise until it will rotate no farther.

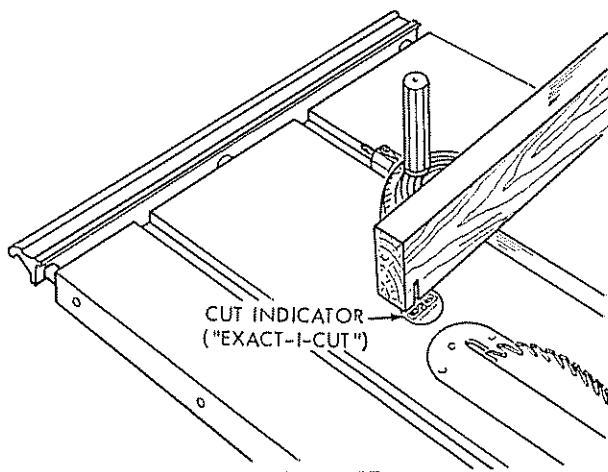

Figure 57

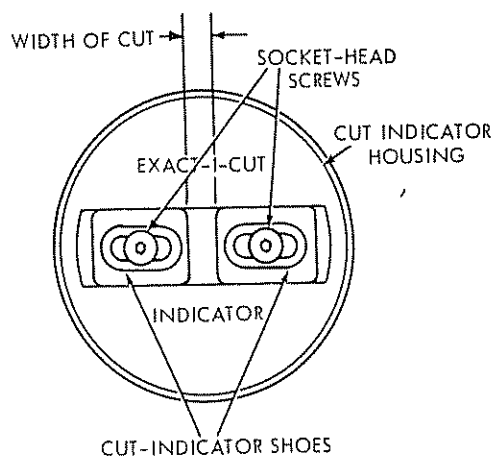

Figure 58

3. With the saw running, place a straight board (preferably hardwood) against the miter gauge and hold it securely.
4. Make a small cut and pull the miter gauge back until the cut is directly on the "Exact-I-Cut". (See figure 57.) If both cut indicator shoes are aligned with the edges of the cut, no adjustment is required. If not aligned, loosen the two socket, flat-head screws with a 1/16-inch hex-L wrench and slide the cut indicator shoes laterally until the edge of each shoe is aligned with its respective edge of the cut in the board. (See figure 58.) Tighten both screws and recheck for accuracy of the adjustment.

## RIPPING

1. The process of sawing wood with the grain is known as "ripping". It is generally done with the aid of a rip fence as a guide to position and maintain the work at correct width for the desired cut. (See figure 59.) Since the work is pushed along the fence, it must have a reasonably straight edge to make sliding contact with the fence. Also, work must make solid contact with the table, so that it will not wobble. Provide a straight edge, even if this means temporarily nailing of an auxiliary straight edge board to the work. If workpiece is warped, turn the hollow side down.
2. The saw guard should be used during all ripping operations. The guard has a splitter which prevents the saw kerf from closing and binding the blade.
3. Set the rip fence to desired width of cut, either by using the scale on the fence guide bar, or measuring the distance between blade and fence. The fence is generally used on right-hand side of blade. Stand a little to the right of center to avoid being sprayed with sawdust and to be clear of work in case of a kickback.
4. Start the saw and advance the work, using the left hand to hold work down and right hand to push it forward. As cut nears completion, move the left hand to a safe distance from saw blade, and push work through with right hand alone.

**CAUTION:** Never reach in back of blade with either hand to hold work down.

5. When the distance between the fence and saw blade is less than the width of your palm, do not attempt to push work through by hand. Use a push stick or pull work through from behind saw. (See figure 60.)
6. Do not leave a long board unsupported so that the spring of the board causes it to shift on the table. Use a support to catch end of board behind the blade. If board is quite long, use another support in front of saw blade. (Figure 61 shows one type of support that is adjustable for height and easily constructed.)

## RESAWING

1. The process of cutting thick boards into thinner ones is known as "resawing". It is a ripping operation. (See figure 62.) Small boards (up to 3-3/8-inch maximum width) can be resawed in one pass, but larger boards (up to 6-1/4-inch maximum) require two passes, one along each edge of the board.
2. When two cuts from opposite edges are required, these

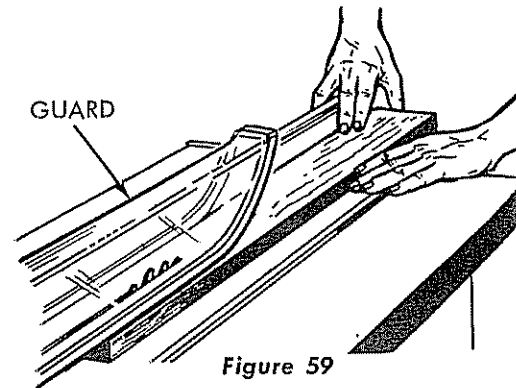

Figure 59

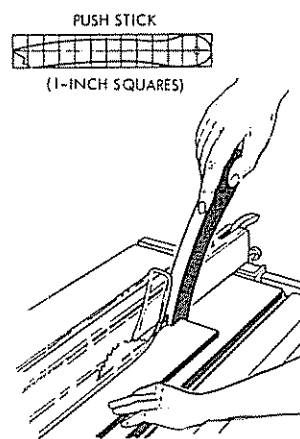

Figure 60

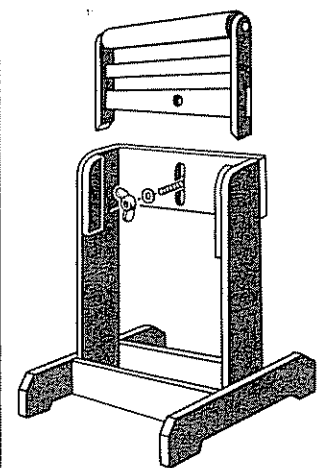

Figure 61

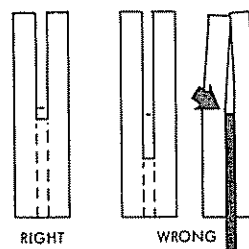

Figure 62

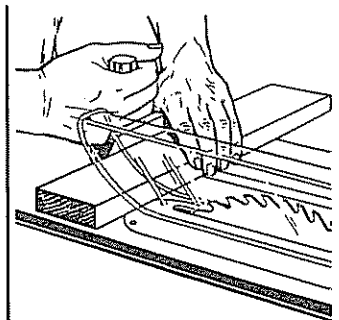

Figure 63

should be made to overlap 1/2-inch from the approximate center of the board.

3. If the first cut is too deep, the kerf will close and bind the saw on the second cut, with danger of kickback. Also, when the kerf closes, the two sides of the cut are no longer parallel to the saw blade, and the saw will cut into them to spoil their appearance. (See figure 62.)
4. Keep same face of board against fence when making both cuts.

## CROSSCUTTING

1. Sawing wood across the grain is known as "crosscutting". (See figure 63.) Boards are milled with the grain running the length of the board.

# proper operating procedures

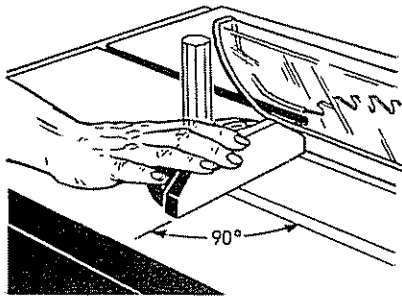

Figure 64

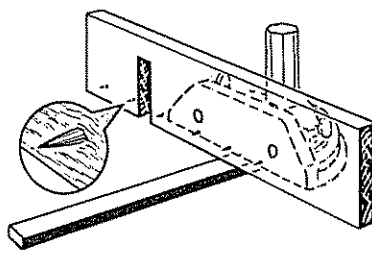

Figure 65

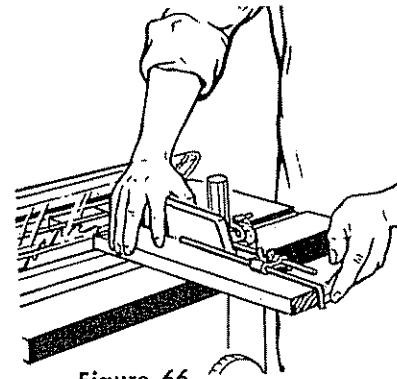

Figure 66

- In crosscutting the long edge of the work is placed across the table top, therefore, the miter gauge is used as a guide instead of the fence. Most operators prefer to use the left-hand table groove. In this case, the left hand is used to hold the work in contact with the gauge. The right hand is placed on the handle and used to advance the work. If right-hand groove is used, hand positions are reversed.
- Ordinarily, the gauge is placed in the table groove with bar in front. When work is so wide that it completely covers the table in front of blade, the gauge should be reversed.
- Square crosscutting is done with the miter gauge set at "0" (at a right angle to the slide and groove). (See figure 64.) The splitter need not be removed, but it is not needed for this operation.
- Start the cut slowly and hold work firmly to table to prevent kickback or chatter. (Loosely held pieces will sometimes vibrate against the table when crosscutting, which tends to bind the saw blade and dull the teeth.)
- An auxiliary wood extension bolted to the miter gauge greatly improves the gauge as a support. (See figure 65.) If fitted with pin points (phonograph needles are excellent) or sandpaper, the extension will help prevent side creep of the work.
- If the work overhangs the saw table enough to sag at each end, provide supports the same as in ripping operations. The stop rod on the miter gauge, or a stop block fastened to the extension, is used to fix position of left-hand edge of work for measuring length of piece to be cut off. (See figure 66.)

## BEVEL AND MITER CUTS

- Bevels from 1 to 45 degrees are cut by tilting the saw blade.
- Operations are the same as for ripping or crosscutting, but work should be extra well supported to prevent creep.
- Miters are crosscuts at an angle to the edge of the work. (See figure 67.) The miter gauge is set at the required angle to make the cut. Here also, precautions must be taken to prevent creep.

## THE DADO HEAD

- The dado saw or head is a special set of blades for cutting grooves and dados with a bench saw. (See figures 68 and 69.) (Dado heads may be purchased at any Sears Retail Store or Catalog Order House.) The head consists of two solid, stiff outside blades, and a number of inside chipper blades. The outside blades are 1/8-inch thick; there is one 1/4-inch, two 1/8-inch, and one 1/16-inch chipper blades. With these blades, grooves of 1/8-inch, 1/4-inch can be cut and additional widths increased in steps of 1/6-inch up to a maximum of 13/16-inch and a maximum depth of 1-3/8-inches.

**NOTE:** Outside blades can be used alone, chipper cannot.

- When using a full set of dado blades, do not use the loose collar. The width of the dado can be reduced while using the loose collar and two or more passes can be made with the work to obtain the desired width of cut.

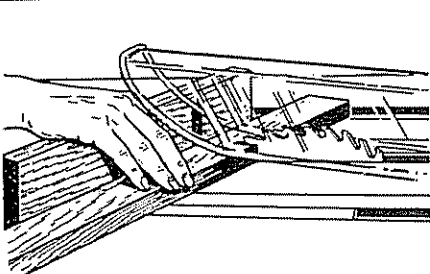

Figure 67

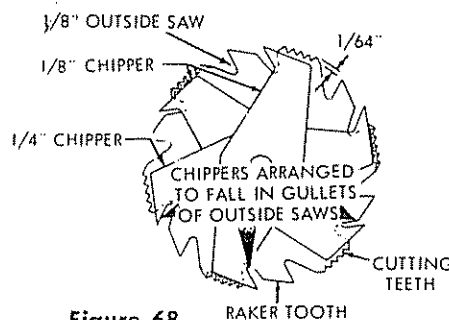

Figure 68

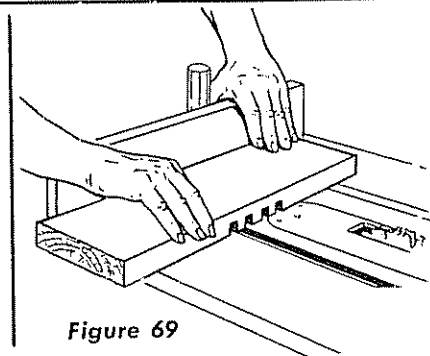

Figure 69

3. A dado insert must be used to replace the standard table insert. When using a full 13/16-inch dado set, the arbor cannot be tilted to 45 degrees without touching the insert. Do not attempt to operate in this position. Also when the dado is set for the maximum depth of cut (1-3/8-inches), be sure to spin the blade by hand before turning on the motor to make sure the blade does not strike the dado insert. Whenever two or more chippers are used, stagger the swaged ends as evenly as possible around the circumference. Fractional adjustments in thickness of the head can be made by using paper washers between the outside blades and chippers.
4. Dado head operations are much the same as those with a standard blade. Since the dado head takes a larger bite, the work should be held more firmly. It is a good practice to use a hold-down jig like the one shown in figure 70.
5. When a groove wider than the dado head is required, make two or more passes. The best method is to use a notched stop block to position each successive cut. (See figure 71.) The block is fastened to edge of table where it can be used to position work before starting the cut, but in a position that will not permit contact with work during the cutting operation. Space the cuts so they overlap slightly.
6. When cutting a gain (a groove that is closed at one end) use a stop block to fix the end of the cut. (See figure 70.) To locate the stop, place the work alongside the dado head in position in which it will be when cut is finished. Then rig the stop at the end of the work. When cutting a stopped groove (which is closed at both ends) also use a starting block, as shown in figure 72. This is located in same manner as the stop block.

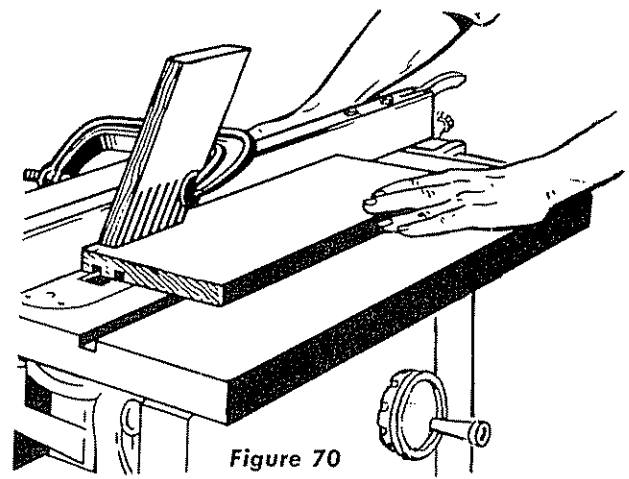

Figure 70

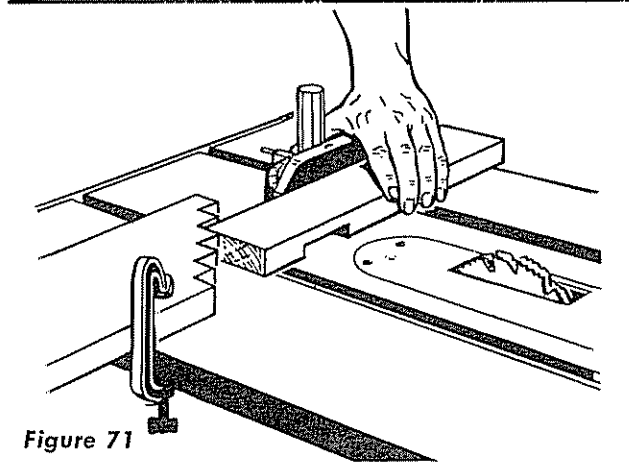

Figure 71

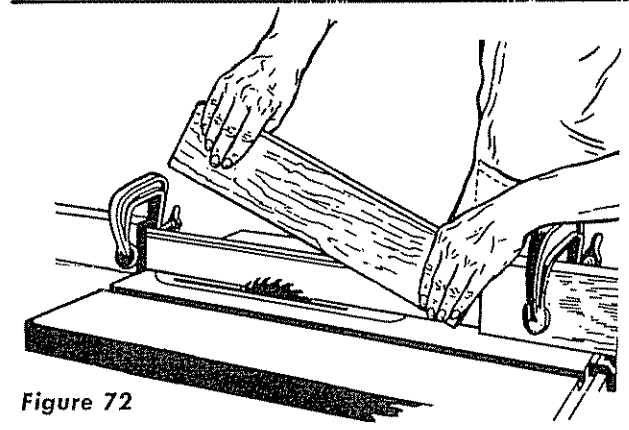

Figure 72

## SANDING

A sanding wheel can be mounted on the saw arbor and the tilting arbor of the saw provides a high degree of versatility for fine sanding operation. (See figure 73.)

## STABILIZING WASHERS FOR THIN BLADES

Stabilizing washers should be used only with thin blades. When using these washers, the maximum depth of cut cannot be obtained and the washers must be kept below the bottom surface of the table insert.

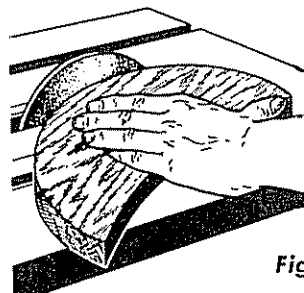

Figure 73

# proper operating procedures

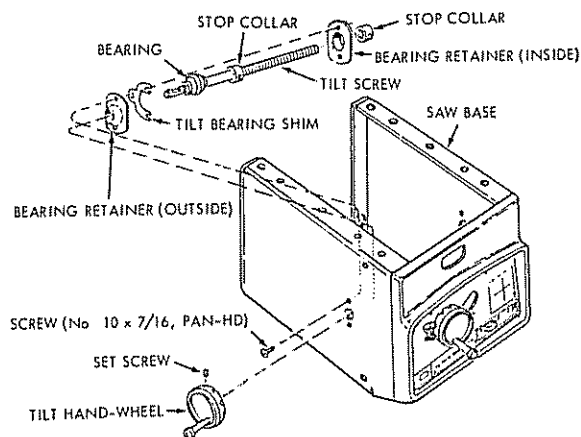

Figure 74

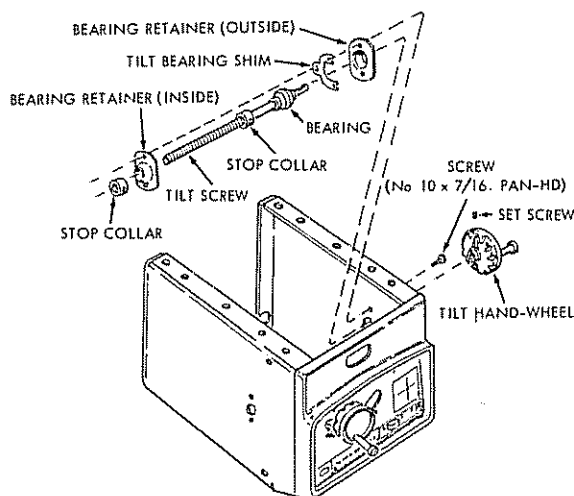

Figure 75

## RELOCATING THE TILT HAND-WHEEL — FROM LEFT SIDE TO RIGHT SIDE OF SAW

The design of this saw permits relocation of the tilt hand-wheel by moving it from the left-hand side to the right-hand side of the saw. Should the operator prefer this hand-wheel on the right, the change may be made as follows:

**NOTE:** Figures 74 and 75 show only the saw base. The table and cradle have been left out for clarity.

### 1. Removal of Parts from Left-Hand Side. (See figure 74.)

- Loosen the set screw in tilt hand-wheel with a 5/32-inch hex-L wrench and remove the tilt hand-wheel from end of tilt screw. (See figure 74.)
- Reach inside saw base from the rear and loosen two set screws in each stop collar just enough to permit the stop collars to rotate easily on tilt screw.
- Remove the stop collar located near the end of tilt shaft.
- Remove two No. 10 x 7/16-inch pan-head screws that secure the bearing retainers to the saw base with a screwdriver.
- Grasp the saw cradle by reaching inside the base from the rear and "tilt" the cradle until the end of tilt screw is withdrawn into the base. The tilt bearing shims will fall out and should be retrieved as they must be re-installed on the opposite side.
- Slide the outside bearing retainer off end of tilt screw and tilt the cradle by hand (while guiding the end of tilt screw into the hole) until the outer end of tilt screw passes through the hole in the saw base.
- Reach inside the base with one hand and hold the stop collar and inside bearing retainer and rotate the tilt screw counterclockwise until free of the threads in saw cradle. While still holding the inside retainer and stop collar, continue to rotate the tilt screw until the stop collar is free of the threads. Withdraw the tilt screw from the hole in the base.

### 2. Installing Parts on Right-Hand Side. (See figure 75.)

- Insert the inner end of tilt screw through the hole in right-hand side of saw base (figure 75) then reach inside of base and slide the inner bearing retainer on the tilt screw, with flat face of retainer toward the tilt screw bearing. Start the stop collar on the threads and rotate it a few inches onto the tilt screw.
- Start the end of tilt screw into threads in saw cradle.
- Continue to rotate the tilt screw clockwise into saw cradle, while at the same time rotating the stop collar outward on tilt screw, until the outer end of tilt screw emerges from the hole inside saw base. It may be necessary to grasp the saw cradle and tilt it by hand enough to permit the outer end of tilt screw to pass through the hole and emerge into the base.
- Slide the outside bearing retainer onto the tilt screw (oriented so it will fit the bearing contour) and rotate the tilt screw counterclockwise until the end passes through the hole in the base.
- Work the outside bearing retainer into position on the bearing and inside the base and slide the inside bearing retainer over the stop collar and into position on the bearing.
- Hold inside and outside bearing retainers in place against the base and start two No. 10 x 7/16-inch pan-head screws into their threads in the inside bearing retainer. Leave the screws loose at this time.
- Slide the same number of tilt bearing shims between the bearing retainers as were removed from the same location and tighten the two No. 10 x 7/16-inch pan-head screws securely.
- Install the tilt hand-wheel and tighten the set screw against the "flat" on end of tilt screw.
- Refer to "Adjust Stop Collars," under "Assembly and Adjustments," and adjust the saw blade to stop at "0°" and "45°" positions as described.



# trouble shooting—accessories

## TROUBLE SHOOTING CHART

TROUBLE	PROBABLE CAUSE	REMEDY
Motor will not run	<ol style="list-style-type: none"> <li>1. Defective On-Off switch</li> <li>2. Defective switch cord</li> <li>3. Defective switch box receptacle</li> <li>4. Motor protector open-circuit, broken</li> <li>5. Low voltage</li> <li>6. Defective motor</li> </ol>	<ol style="list-style-type: none"> <li>1. Replace switch.</li> <li>2. Replace switch cord.</li> <li>3. Replace switch box receptacle.</li> <li>4. Reset protector by pushing on red button, located on side of motor (indicated by audible click).</li> <li>5. Check power line for proper voltage.</li> <li>6. Repair or replace the motor.</li> </ol>
Excessive vibration	<ol style="list-style-type: none"> <li>1. Improper motor tension</li> <li>2. Blade out of balance</li> </ol>	<ol style="list-style-type: none"> <li>1. See "Adjusting Pivot Arm Screw" under "Periodic Maintenance Operations".</li> <li>2. Use a different blade.</li> </ol>
Cannot make square cut when crosscutting	<ol style="list-style-type: none"> <li>1. Miter gauge not adjusted properly</li> <li>2. Blade not properly aligned</li> </ol>	<ol style="list-style-type: none"> <li>1. See "Check and Adjust the Miter Gauge" under "Assembly and Adjustments".</li> <li>2. See "Align Saw Blade with Table Grooves" under "Assembly and Adjustments".</li> </ol>
Cut binds, burns or stalls motor when ripping	<ol style="list-style-type: none"> <li>1. Dull blade with improper tooth set</li> <li>2. Warped board</li> <li>3. Blade not properly aligned</li> <li>4. Rip fence not properly aligned</li> <li>5. Guard splitter out of alignment</li> </ol>	<ol style="list-style-type: none"> <li>1. Check set and sharpness of blade.</li> <li>2. True up material.</li> <li>3. See "Align Saw Blade with Table Grooves" under "Assembly and Adjustments".</li> <li>4. See "Check and Adjust the Rip Fence" under "Assembly and Adjustments".</li> <li>5. Align splitter with saw blade.</li> </ol>
Blade not true at 0° or 45°	<ol style="list-style-type: none"> <li>1. Stop collars not properly adjusted</li> </ol>	<ol style="list-style-type: none"> <li>1. See "Adjust Stop Collars" under "Assembly and Adjustments".</li> </ol>
Tilt and elevating screw hand-wheels turn hard	<ol style="list-style-type: none"> <li>1. Dirt and need of lubrication</li> </ol>	<ol style="list-style-type: none"> <li>1. See "Lubricate Saw" under "Periodic Maintenance Operations".</li> </ol>

## ACCESSORIES

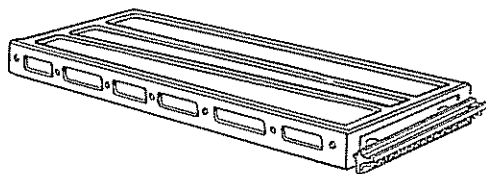

SIDE EXTENSION ASSEMBLY

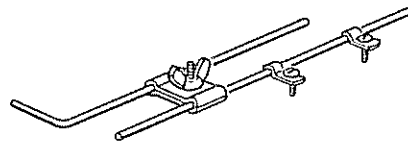

STOP ROD ASSEMBLY

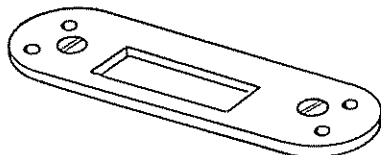

DADO INSERT

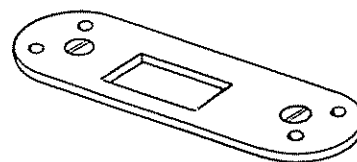

MOLDING HEAD INSERT

# repair parts

## 10-INCH TILTING ARBOR BENCH SAW MODEL No. 113.29940

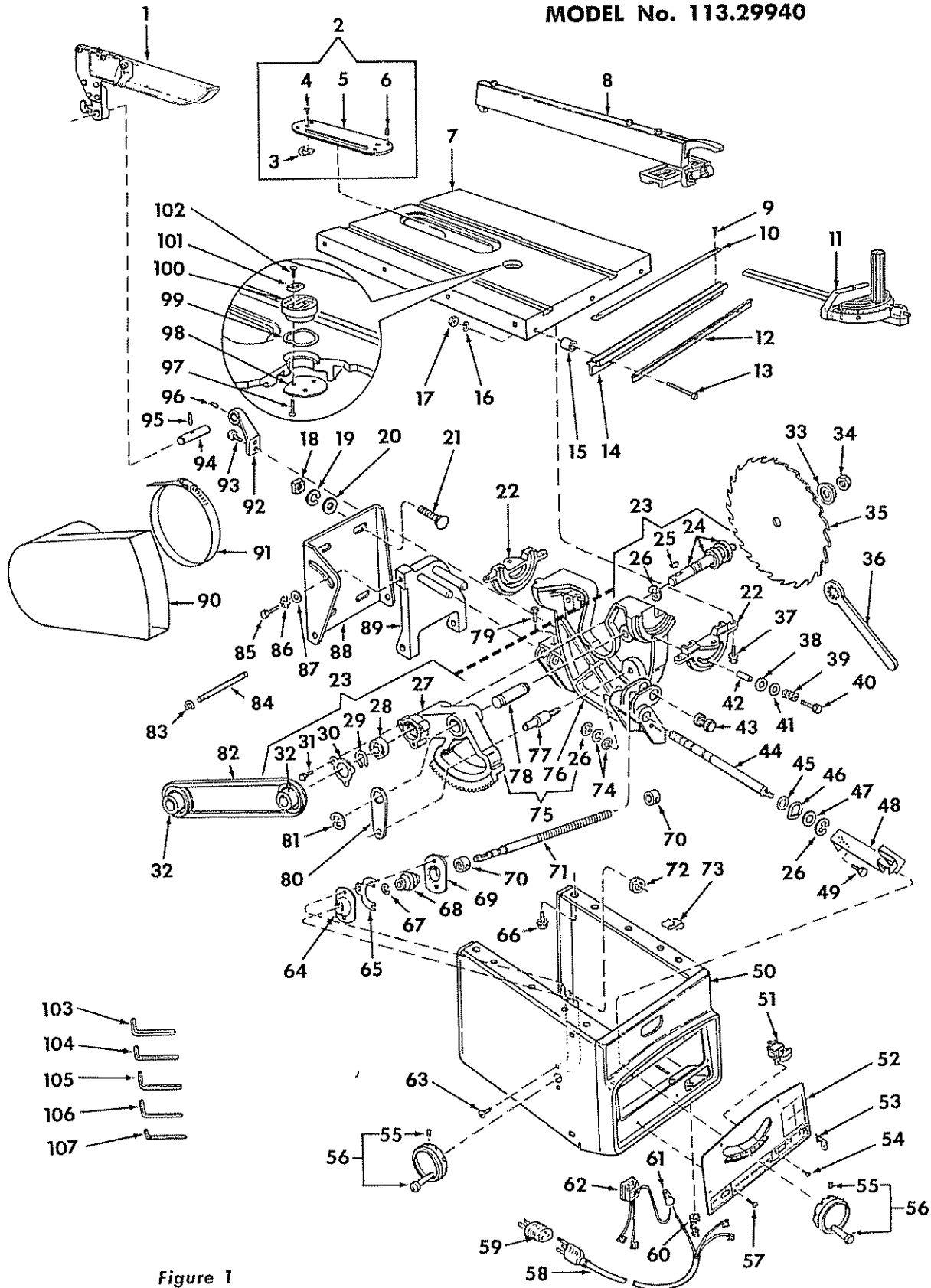

Figure 1

## 10-INCH TILTING ARBOR BENCH SAW, MODEL No. 113.29940

WHEN ORDERING REPAIR PARTS, ALWAYS GIVE THE FOLLOWING INFORMATION AS SHOWN IN THIS LIST:

- |                    |   |
|--------------------|---|
| 1. THE PART NUMBER | 3. THE MODEL NUMBER — 113.29940         |
| 2. THE PART NAME   | 4. THE NAME OF ITEM — 10-INCH BENCH SAW |

Always order by Part Number — not by Key Number

### FIGURE 1 PARTS LIST

Key No.	Part No.	Description	Key No.	Part No.	Description
1	62286	Guard Assembly, Saw (See Fig. 4)	37	423571	*Screw, Mach. w/Ext. Tooth
2	62287	Insert Assembly, Table			Lockwasher, 3/8-16 x 1", Hex. Hd.
3	62074	Catch, Spring	38	60062	*Washer, .380 x 3/4 x 3/32", Steel
4	144630	*Screw, Mach., No. 4 x 5/16", Flat Hd., Steel	39	60205	Spring, Screw Clamp
5	62288	Insert, Table	40	60206	*Screw, Tapping, 1/4-20 x 1-1/2", Hex. Washer Hd., Steel
6	140879	*Screw, Set, No. 10-32 x 3/16", Hex. Socket Hd., Cup Pt.	41	63011	Washer, Screw Clamp
7	62289	Table	42	62295	Spacer, Screw Clamp
8	62290	Fence Assembly, Rip (See Fig. 1)	43	37899	Nut, Tilt
9	60049	*Screw, Self-Tapping, No. 4-40 x 3/16", Pan Hd.	44	62296	Screw, Lift
10	62228	Tape, Fence	45	30653	"O" Ring
11	62209	Gauge Assembly, Miter (See Fig. 3)	46	60178	Washer, Lift Spring
12	62212	Rack, Table	47	37838	*Washer, Plain, .629 x 7/8 x 1/64", Steel
13	133063	*Screw, Mach., 1/4-20 x 2", Rd. Hd., Slotted	48	62297	Pointer, Lift
14	62211	Bar, Fence Guide	49	448633	*Screw, Tapping, No. 10-32 x 3/8", Hex. Hd.
15	62011	Spacer, Fence Guide Bar	50	62298	Base
16	115109	*Washer, Med. Lock, 1/4"	51	62299	Switch
17	115120	*Nut, Hex., 1/4-20 x 7/16 x 3/16", Steel	52	62300	Panel Assembly, Trim
18	120399	*Nut, Square, 5/16 x 9/16 x 7/32"	53	37861	Key
19	131201	*Washer, Lock, 5/16 x .125 x .078"	54	448001	*Screw, Tapping, No. 6-32 x 1/4", Pan Hd.
20	118774	*Washer, 11/32 x 7/8 x 1/16", Steel	55	102570	Screw, Set, 1/4-20 x 7/16", Socket Hd., Cup Pt.
21	126218	*Bolt, Carriage, 5/16-18 x 3/4"	56	62250	Crank Assembly
22	30426	Trunnion, Table	57	111688	*Screw, Type B, No. 8 x 5/16", Pan Hd.
23	30419	Housing Assembly, Arbor	58	62301	Cord
24	6532	Arbor Assembly	59	37568	Adapter Plug
25	106751	Key, Arbor	60	60207	Relief, Cable Strain
26	30442	Ring, Retaining	61	71046	Connector, Wire
27	30420	Housing, Arbor	62	62302	Outlet
28	3509	Bearing, Arbor	63	145189	*Screw, Type B, No. 10 x 7/16", Pan Hd.
29	37158	Ring, Bearing Retainer	64	62303	Retainer, Inside Bearing
30	3508	Retainer, Arbor Bearing	65	62304	Shim, (.005 Thick)
31	448611	*Screw, Tapping, No. 8-32 x 3/8", Hex. Ind. Hd., Steel		62305	Shim, (.010 Thick)
32	30646	Pulley	66	423350	*Screw, Mach., w/Ext. Tooth
33	63017	Collar, Loose			Lockwasher, 3/8-16 x 1/2" Hex. Hd., Cad. Pl. Steel
34	6362	Nut, Arbor	67	60045	Ring, Retaining
35	60175	†Blade, Chisel Tooth			
36	3540	Wrench, Arbor			

# repair parts

## 10-INCH TILTING ARBOR BENCH SAW, MODEL No. 113.29940

### FIGURE 1 PARTS LIST — (Continued)

Key No.	Part No.	Description	Key No.	Part No.	Description
68	62306	Bearing	90	62293	Guard, Belt
69	62307	Retainer, Outside Bearing	91	62294	Clamp, Ring
70	37900	Collar, Stop	92	62292	Support Guard
71	62308	Screw, Tilt	93	60025	*Screw, Mach., 5/16-18 x 1", Hex. Ind. Hd.
72	62285	Grommet	94	62111	Rod, Splitter
73	62204	Clip, Cord	95	273336	Pin, Roll
74	30767	Washer, End Play (.005 Thick)	96	102582	Screw, Set, 5/16-18 x 1/2", Socket Hd., Cup Pt.
75	62309	Cradle Assembly	97	436693	*Screw, Mach., No. 8-32 x 3/8", Pan Hd.
76	62310	Cradle	98	38747	Plate, Cut Indicator
77	62311	Pin, Stop	99	38746	Washer, Spring
78	6534	Pin, Pivot	100	62257	Housing, Cut Indicator
79	9415812	*Screw, Mach., 5/16-18 x 5/8", Hex. Ind. Hd.	101	38845	Shoe, Cut Indicator
80	62312	Link	102	60195	*Screw, No. 4-40, Flat Hex. Socket Rec. Hd.
81	6527	Ring, Retaining	103	60194	Wrench, Hex.-L (1/16")
82	37945	†Belt, V-Type, 1/2 x 41"	104	37836	Wrench, Hex.-L (3/32")
83	60044	Ring, Retaining	105	30505	Wrench, Hex.-L (1/8")
84	37823	Pin, Hinge	106	37837	Wrench, Hex.-L (5/32")
85	30628	Screw, Pivot Arm	107	37911	Wrench, Hex.-L (3/16")
86	6423	Washer, Spring	▲	62313	Operating Instructions and Parts List for Craftsman 10-Inch Bench Saw — Model 113.29940
87	60005	*Washer, 17/64 x 3/4 x 1/16", Zinc Pl. Steel			
88	37824	Base, Motor			
89	37825	Support Assembly, Motor Base			

\* Standard Hardware Item — May be Purchased Locally.

† Stock Item — may be secured through the Hardware Departments of most Sears or Simpsons-Sears Retail Stores or Catalog Order Houses.

### BENCH POWER TOOL GUARANTEE

During the first year, we will repair your Craftsman Bench Saw free of charge, if defective in material or workmanship.

This guarantee service is available by simply returning the Saw to any Sears Store throughout the United States.

## 10-INCH TILTING ARBOR BENCH SAW, MODEL No. 113.29940

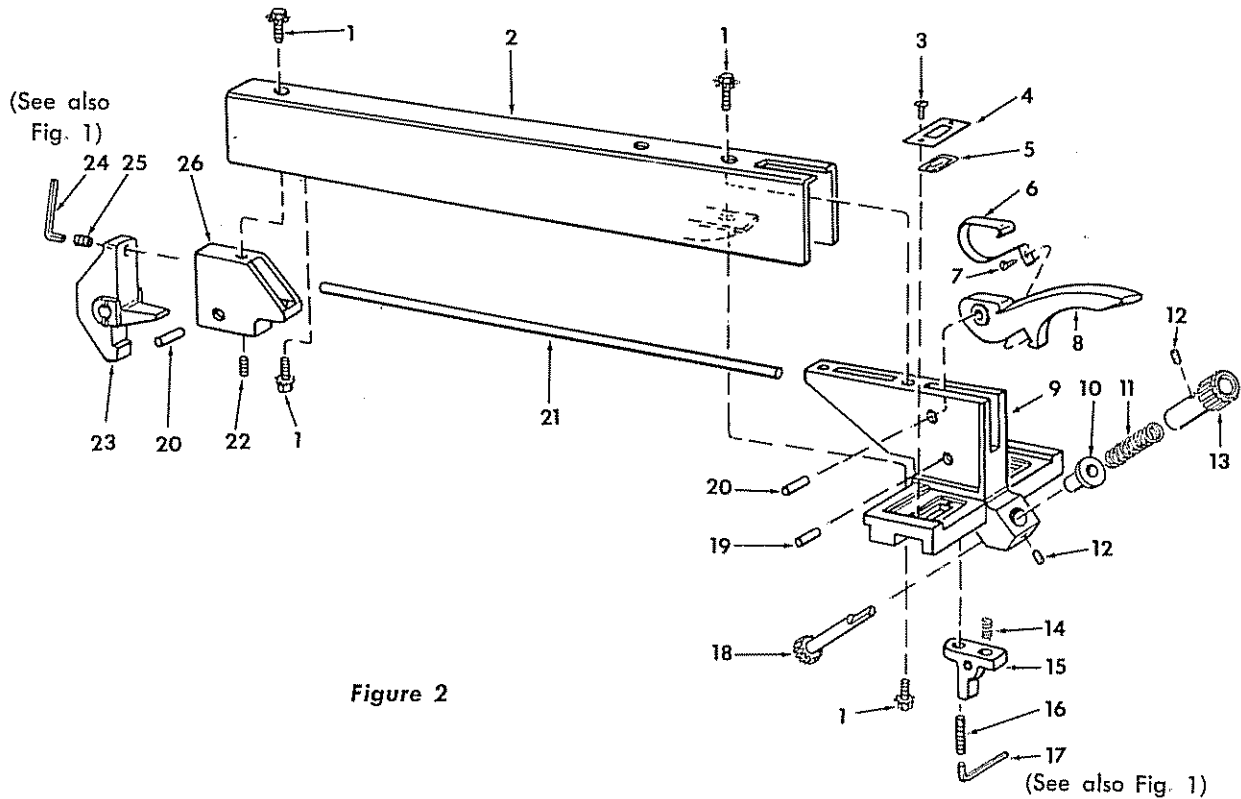

Figure 2

### FIGURE 2 PARTS LIST

Key No.	Part No.	Description	Key No.	Part No.	Description
1	62290	Fence Assembly, Rip	13	62132	Knob, Fence Adjusting
	423350	*Screw, Mach., w/Ext. Tooth Lockwasher, 3/8-16 x 1/2", Hex. Hd., Steel		14	62049
2	62126	Channel Assembly, Fence	15	62048	Pawl, Fence
3	60049	*Screw, Tapping, No. 4-40 x 3/16", Pan Hd. Slotted, Cad. Pl. Steel	16	222412	*Screw, Set, 1/4-20 x 1", Hex. Socket Hd., Flat Pt.
4	62052	Retainer, Fence Index	17	30505	*Wrench, Hex.-L (1/8")
5	62051	Indicator, Fence	18	62129	Shaft Assy., Fence Adjusting
6	62046	Shoe, Cam Face	19	62050	Pin
7	436732	*Screw, Mach., No. 10-24 x 1/2", Pan Hd. Slotted, Cad. Pl. Steel	20	62047	Pin
8	62291	Handle, Fence Lock	21	62128	Rod, Lock
9	62127	Head, Fence	22	62055	Spring, Fence Lock
10	62130	Bushing, Fence Adjusting Shaft	23	62073	Lock, Fence
11	62131	Spring, Fence Adjusting Shaft	24	37837	*Wrench, Hex.-L (5/32")
12	60067	*Screw, Set, 1/4-20 x 1/4", Hex. Socket Hd., Cup Pt.	25	222469	*Screw, Set, 5/16-18 x 1/2", Hex. Socket Hd., Flat Pt.
26	62053	Support, Fence Lock			

\* Standard Hardware Item — May be Purchased Locally.

## 10-INCH TILTING ARBOR BENCH SAW, MODEL No. 113.29940

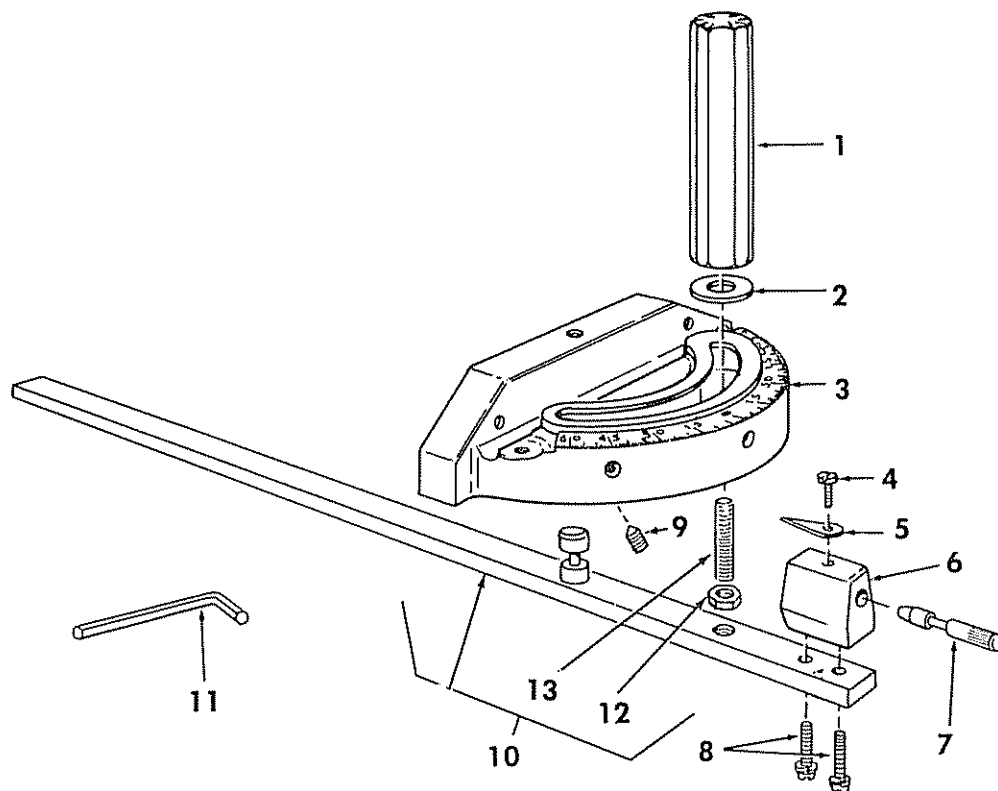

Figure 3

### FIGURE 3 PARTS LIST

Key No.	Part No.	Description	Key No.	Part No.	Description
1	62209 62068	†Gauge Assembly, Miter Handle, Miter Gauge	8	9417295	*Screw, Mach., w/Lockwasher, No. 8-32 x 5/8", Pan Hd. Slotted, Cad. Pl. Steel
2	60024	*Washer, Plain, .320 x 1 x 1/16", Zinc Pl. Steel	9	139325	*Screw, Set, 1/4-20 x 3/8", Hex. Socket Hd., Cone. Pt.
3	37893	Gauge, Miter	10	62230	Rod Assembly, Miter Gauge
4	9404365	*Screw, Mach., No. 8-32 x 5/16", Pan Hd. Slotted, Cad. Pl. Steel	11	30505	*Wrench, Hex.-L (1/8")
5	135	Indicator	12	124824	*Nut, Hex-5/16-18 x 1/2 x 3/16"
6	37895	Block, Miter Gauge Indicator	13	62225	Stud, Clamp
7	37896	Pin, Miter Gauge Stop			

\* Standard Hardware Item — May be Purchased Locally.

† Stock Item — May be secured through the hardware departments of most Sears or Simpsons-Sears Retail Stores or Catalog Order Houses.

## 10-INCH TILTING ARBOR BENCH SAW, MODEL No. 113.29940

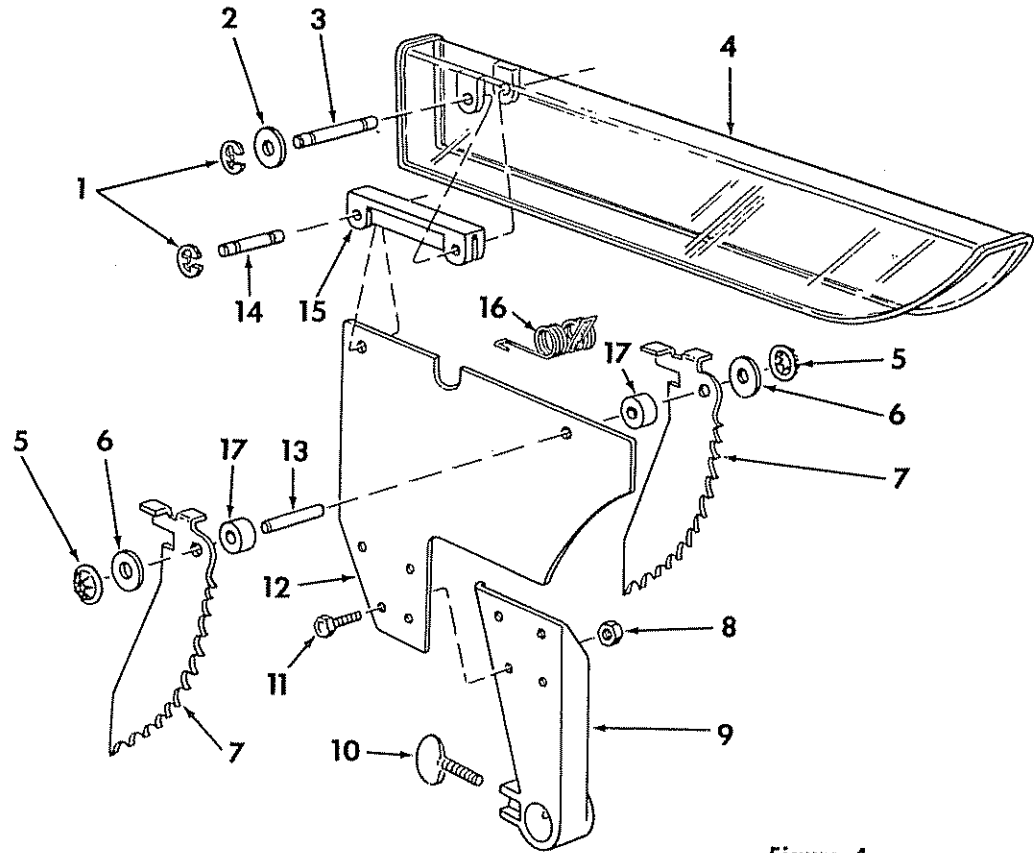

Figure 4

### FIGURE 4 PARTS LIST

No. Key	No. Part	Description
	62286	Guard Assembly, Saw
1	60004	Ring, Retaining
2	9414920	*Washer, Plain, 17/64 x 5/8 x 1/32", Cad. Pl. Steel (2 required)
3	37902	Pin, Guard
4	37901	Guard
5	60208	Nut, Push
6	60128	*Washer, Plain, 17/64 x 5/8 x 1/16", Cad. Pl. Steel
7	62135	Pawl
8	115120	*Nut, Hex., 1/4-20 x 7/16 x 3/16"

Key No.	Part No.	Description
9	62210	Support, Splitter
10	60204	Screw, Thumb
11	9415698	*Screw, Mach., 1/4-20 x 5/8", Hex. Ind. Hd.
12	62359	Blade, Splitter
13	60209	Pin
14	37905	Pin, Bearing
15	62138	Link, Guard
16	62134	Spring, Pawl
17	62136	Spacer

\* Standard Hardware Item — May be Purchased Locally.

Sears

# owners manual

## CRAFTSMAN 10-INCH TILTING ARBOR BENCH SAW

MODEL No.  
113.29940

### HOW TO ORDER REPAIR PARTS

SEARS SERVICE  
IS AT YOUR SERVICE  
WHEREVER YOU LIVE  
OR MOVE IN THE U.S.A.

The Model Number will be found on a plate attached to your saw, at the rear of the base. Always mention the Model Number when requesting service or repair parts for your 10-INCH BENCH SAW.

All parts listed herein may be ordered through SEARS, ROEBUCK AND CO. or SIMPSONS-SEARS LIMITED. When ordering parts by mail, selling prices will be furnished on request or parts will be shipped at prevailing prices and you will be billed accordingly.

WHEN ORDERING REPAIR PARTS, ALWAYS GIVE THE FOLLOWING INFORMATION AS SHOWN IN THIS LIST.

1. The PART NUMBER
  2. The PART DESCRIPTION
  3. The MODEL NUMBER
  4. The NAME of ITEM — 10-INCH BENCH SAW
- 113.29940

Your Sears merchandise takes on added value when you discover that Sears has over 2,000 Service Units throughout the country. Each is staffed by Sears-trained, professional technicians using Sears approved parts and methods.

SEARS, ROEBUCK AND CO. U.S.A.  
SIMPSONS-SEARS LIMITED, CANADA