

OPERATING INSTRUCTIONS
AND PARTS LIST FOR
CRAFTSMAN JOINTER
6 INCH

Model Number 103.23320

This is the model number of your jointer. It will be found on a plate located on the right side of the front table. Always mention this model number when communicating with us regarding your jointer or when ordering parts.

How to Order

Parts for Model Number 103.23320

All parts must be ordered through a Sears' retail or mail order store. Parts are shipped prepaid. When ordering repair parts, always give the following information:

1. The Part Number in this list.
2. The Part Name and Price in this list.
3. The Model Number which is 103.23320 and will be found on a plate on the front table.

This list is valuable. It will assure your being able to obtain proper parts service. We suggest you keep it with other valuable papers.

SEARS, ROEBUCK and CO.

**ASSEMBLING and OPERATING INSTRUCTIONS
FOR CRAFTSMAN 6 INCH JOINTER**

MODEL NUMBER 103.23320

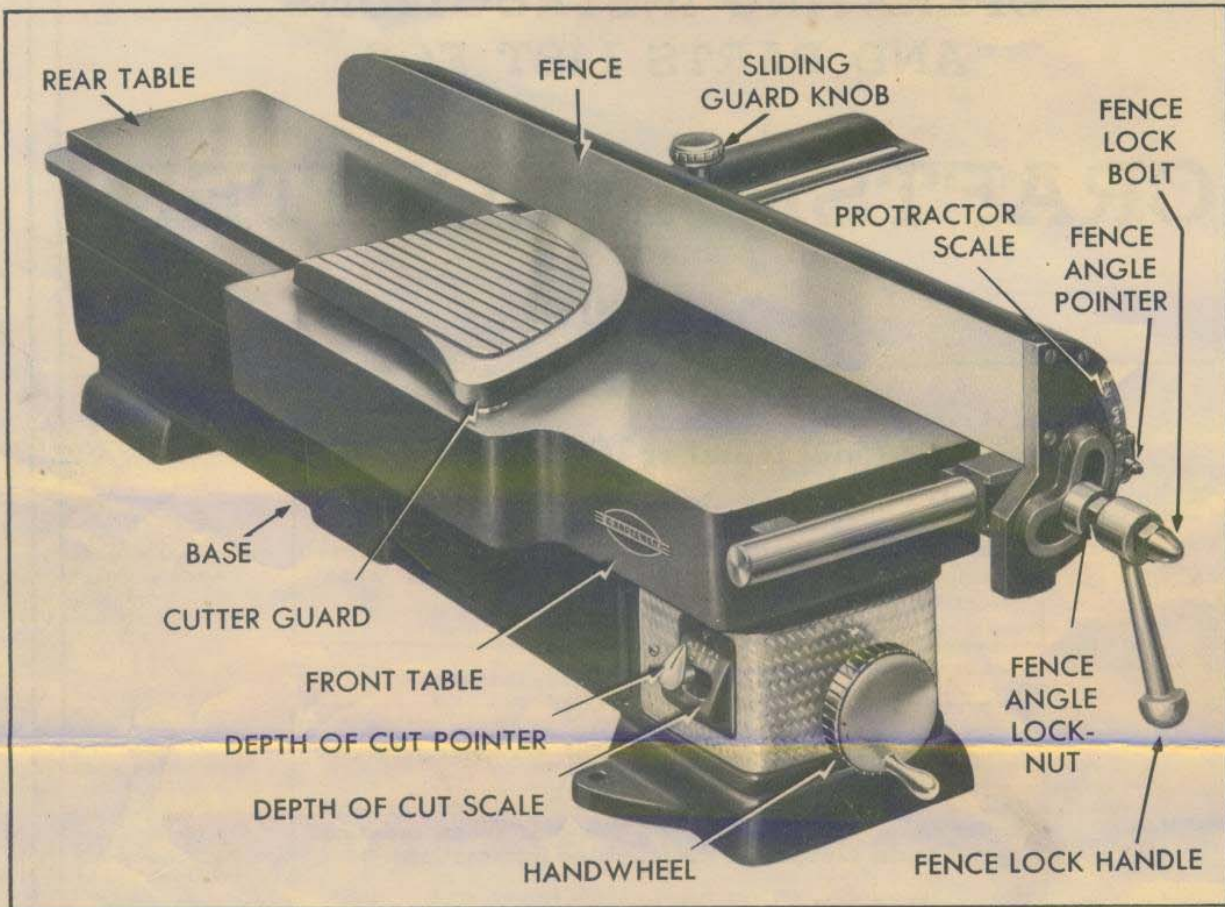

FIGURE 1

REASSEMBLING:

Your jointer has been completely assembled, inspected and tested at the factory. To prevent damage and misalignment of parts during shipping, the cutter guard (see Figure 1) was removed and packed separately. When installing this guard, engage the hexagon stud in the swinging guard insert #21412 in operating position and drop the guard in place.

LUBRICATION:

This tool is equipped with two precision type ball bearings which are fully enclosed in dust proof housings. These bearings were packed with grease at the factory and require no additional lubrication for the life of the bearing. Other moving parts such as the elevation screw #21614 and the upper and lower dovetails #21218 and #21219 may need an occasional application of a light grade oil to insure smooth operation.

INSTALLATION:

The jointer should be mounted securely on a bench

or stand so that the surface of the table is approximately 35" from the floor. The motor should be installed below on a wooden shelf. The jointer pulley is designed to use a 1/2" Vee type belt. **Cutter head rotation must be counter clockwise as viewed from the pulley side of the jointer.** Pulley alignment, and belt tension adjustment, as well as direction of rotation should be considered when installing the jointer and its power unit.

SPEED:

For best results the jointer should be operated at approximately 4400 R.P.M. Satisfactory operating power and speed may be attained by using a 1/2 horsepower 3450 R.P.M. motor equipped with a 2 1/2 inch diameter pulley.

CONTROLS:—Figure 1

The position of the fence is maintained by the clamping action of the fence angle lock nut and the fence lock bolt. The fence lock handle is a wrench designed so that it may be used interchangeably and

independently on either of the above units. The fence may be positioned at any point across the table by loosening the fence lock bolt and the sliding guard knob and moving the entire fence assembly along the fence slide bar #21616. The angle between the fence and the table may be changed for beveling operations by loosening the fence angle lock nut and the sliding guard knob. The angle selected for the bevel cut is indicated on the protractor scale. After changing the fence position as described above, check carefully that the fence angle lock nut, fence lock bolt, and the sliding guard knob are all secure before proceeding with a cutting operation.

The sliding guard knob functions as a lock to secure the sliding guard which supports the fence after it has been positioned.

The hand-wheel is used to raise and lower the front table, thus regulating the depth of cut as indicated by the depth of cut pointer and scale.

ADJUSTMENTS:

If at any time the cut obtained should vary from that indicated on the depth of cut scale, the following adjustment may be made. Align the front and rear tables with a straight edge as indicated in Figure 2. Loosen the screws in the depth of cut scale #21711 and set the scale so the 0 mark lines up with the pointer. Do not forget to tighten the screws in the scale after the above adjustment is made.

If a 90° setting on the fence angle protractor does not produce square cuts, the fence may be reset square with the table by using an accurate tri-square. After the 90° relation between the fence and table has been established, the screw holding the fence

angle pointer may be loosened and the pointer reset at 0.

If a gouge or step is produced at the end of a cut, it is an indication that the rear table is too low. Likewise, the cut may diminish or taper as the work is pushed through, as a result of a high rear table. Either of these conditions may be rectified by aligning the table surfaces in the following manner. (See Figure 2.) Set the front table on the 0 mark on the depth of cut scale. Back the lock screws out several turns. The rear table surface may then be raised or lowered by turning any or all of the three leveling jacks #21611. When the rear table has been adjusted so that the straight edge shows perfect alignment between the two table surfaces across their full width, the lock screws may be tightened. The leveling jacks must be held secure while turning the lock screws.

After correct table alignment has been established, if the depth of cut varies between two sides of a piece it is an indication that the cutter head is not properly aligned with the front table surface. If the work piece hits the edge of the rear table instead of passing smoothly over its surface, the cutter head is too low. Adjustments may be made to correct either or both of these difficulties. Remove the two covers #21717 and #21718 and loosen the four arbor mounting bracket screws #X205. A screw #X217 in the bottom of each bracket #21214 and #21215 when turned will raise and lower the cutter head the small amount necessary to align it properly or to level it with the table surfaces. The leveling adjustment of both the cutter head and the rear table is always made in relation to the front table.

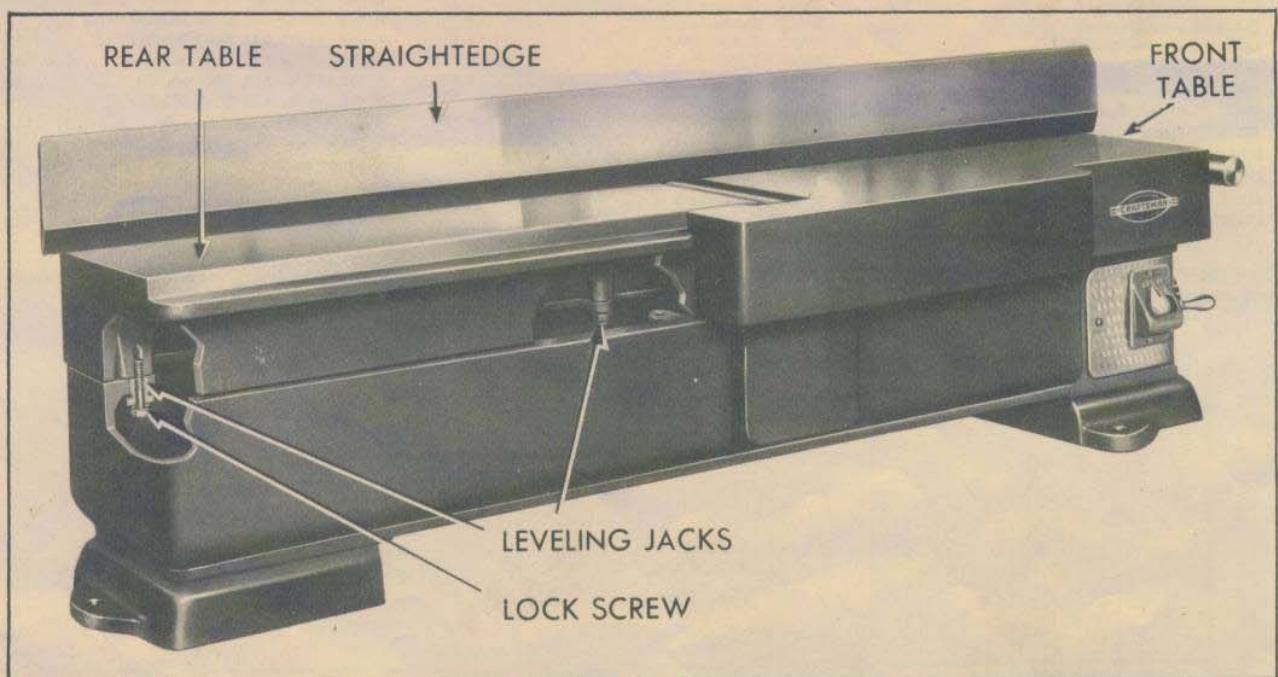

FIGURE 2

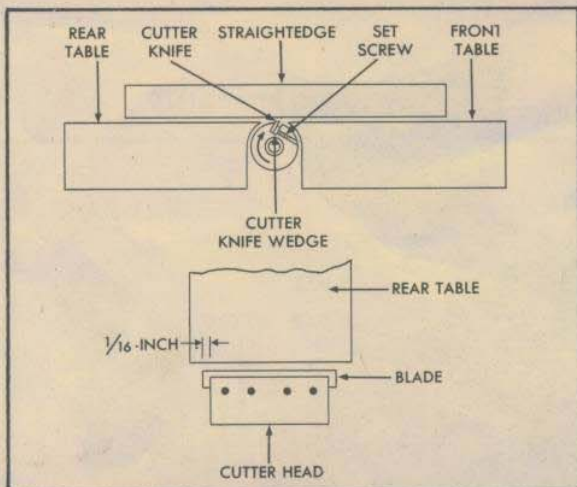

FIGURE 3

SHARPENING THE BLADES:

The three $6\frac{1}{8}$ inch high speed steel cutter knives will give satisfactory cutting service for many hours of operation without regrinding, if they are honed occasionally with a fine abrasive stone to retouch the edge. This operation can be performed as shown in Figure 4. It is not necessary to remove the cutter blades from the head. Before honing, cover part of the stone with paper as shown, so the table surface will not be injured. For satisfactory results, the original bevel angle must be maintained on the knives. Adjust the front table so that the stone presses lightly against the full width of the knife bevel. Secure the cutter-head in the desired position by inserting a wooden wedge between the cutter head and table, as shown. Place the paper covered portion of the stone on the front table, and by moving the stone back and forth, hone the *full length* of each knife in turn. The small burr on the flat side of the blades may be removed by a few light strokes with a fine abrasive stick or a piece of emery cloth.

RESETTING BLADES:

If the blades are removed for grinding or replacement, care must be exercised at the time of reinstallation. Both tables should be level. All three blades should project $1/16$ inch at each end of the cutter head (See Figure 3). With their edges projecting slightly above the surface of the tables, the blades may be clamped lightly in position with the four set screws #X121 and the wedge #18113 provided for each blade. With the straight-edge

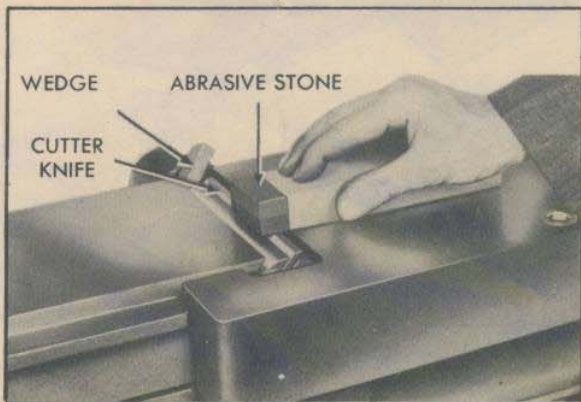

FIGURE 4

placed as shown, the blades may be properly positioned by tapping with a piece of hardwood until each knife will touch the straight-edge lightly at either end of the cutter head. When all three knives have been aligned in the above manner, tighten the twelve set screws securely.

Trial cuts should be made after any adjustment or repositioning to insure that no other control unit has been disturbed and that all controls are functioning in proper relation to each other.

OPERATION:

The cutter guard shown in Figure 1 should be in operating position at all times except during rabbeting at which time the sliding guard covers the unused portion of the cutter head. For the rabbeting operation, the fence is shifted from its normal position at the right hand edge of the table to the desired position on the left hand side. The width of cut is determined by the distance from the end of the cutter knives to the fence. Depth of cut is determined by the position of the front table as previously described.

Face planing or surfacing is the most common function of the jointer, yet extreme care must be exercised during this operation. The depth of cut is determined by the width of the material; the wider the material, the less the cut. In most cases a $1/32$ cut will produce the best surface. Deeper cuts should be made in successive stages until the full depth has been attained. The work should be advanced through the guard to the cutter head with a smooth slow feed. Both hands should be placed on top of the work piece, the left hand pressing the piece firmly against the rear table surface, the right hand exerting the feed pressure over the front table.

When cutting pieces over four feet in length, the most uniform cut will be maintained by supporting the piece at table height after it leaves the rear table surface. Warped stock should be cut on the concave side for best results. To avoid pitting or torn grain it is advisable, where ever possible, to determine which way the grain emerges on a piece of wood. The direction of feed should be governed accordingly; the grain should emerge on the lower surface of the wood and should point toward the front of the jointer.

When surfacing thin stock ($1/2$ inch or less) a push block should always be used.

Because of the cut-out in the lower edge of the fence, designed for clearance at maximum depth of cut setting, a guide surface is not available beyond the cutter head when surfacing stock less than $9/16$ inch thick. It is sometimes necessary to clamp an auxiliary face to the fence. This face should be attached after the front table position has been established, and should rest on the rear table surface.

The function of the fence in the beveling operation has been described in the paragraph on controls.

Guards and covers have been provided at all necessary points. For your safety we recommend that these be kept in place at all times during the operation of the jointer.

An interesting booklet covering special operations which may be performed on your jointer is available through your Sear's retail or mail order store.

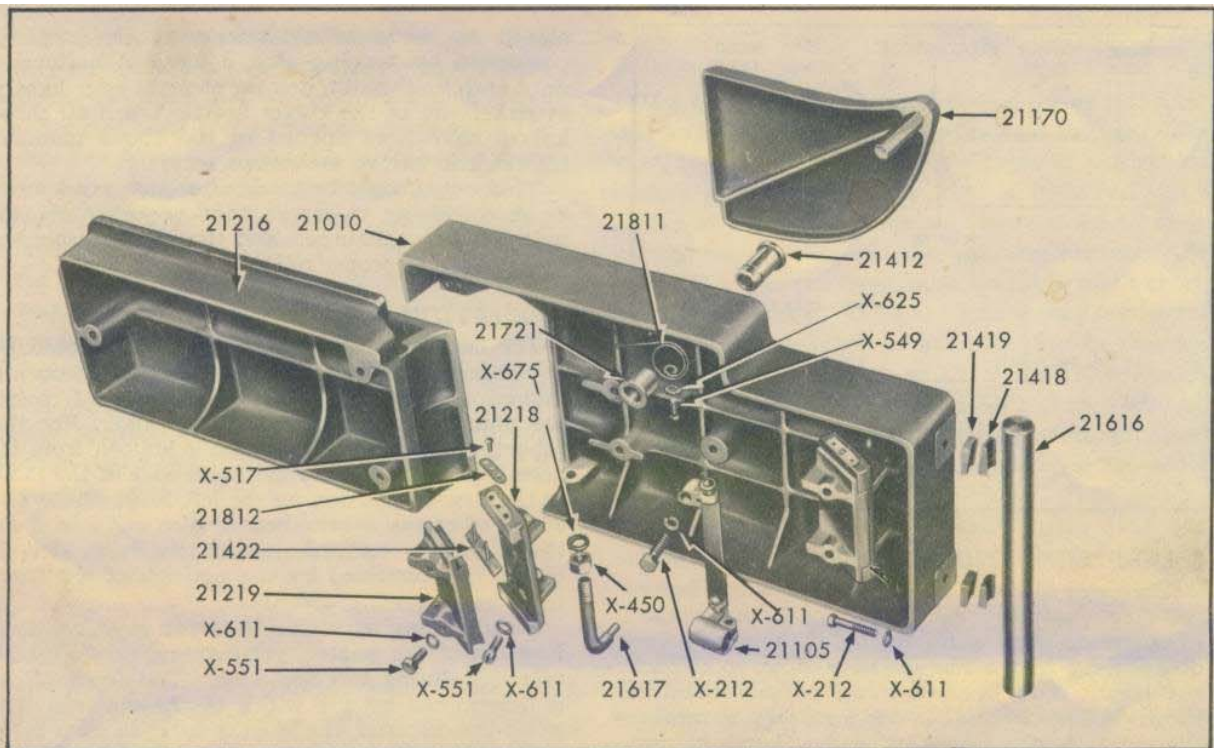

TABLES AND ASSOCIATED PARTS

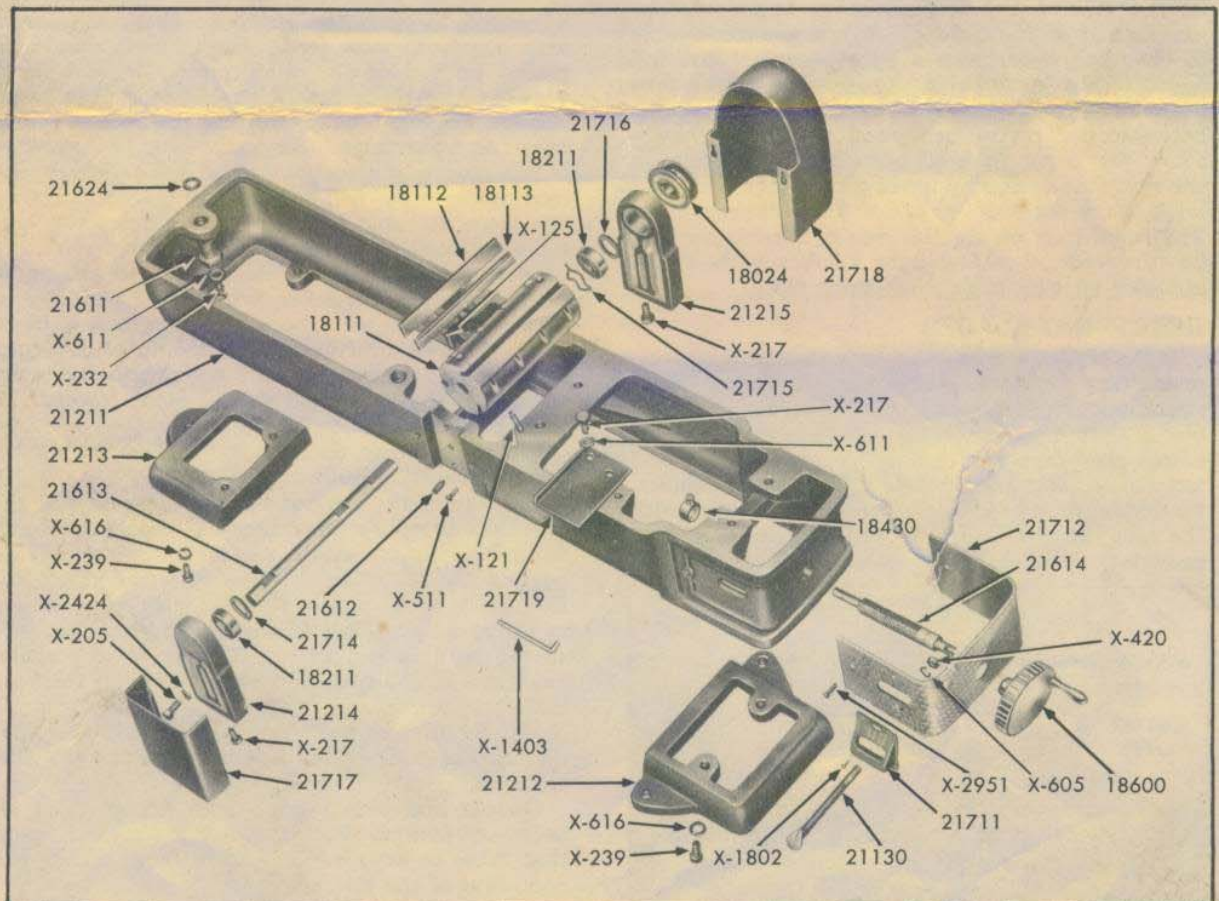

BASE AND ASSOCIATED PARTS

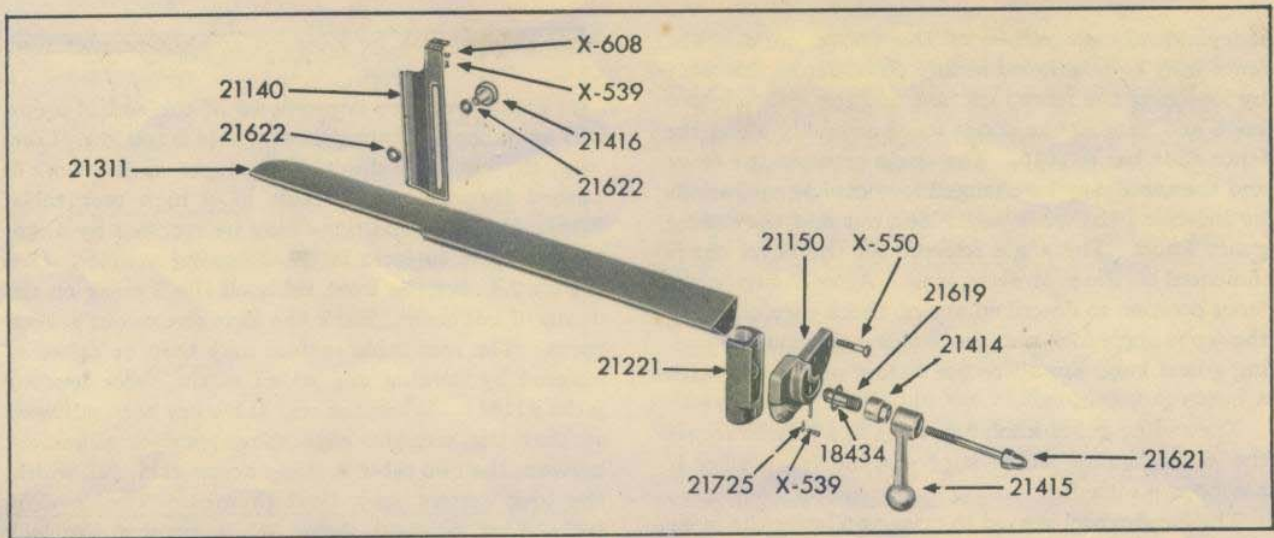

FENCE ASSEMBLY

Parts List

| Part Number | NAME | Prepaid Selling Price Each | Part Number | NAME | Prepaid Selling Price Each | Part Number | NAME | Prepaid Selling Price Each |
|------------------------------------|--------------------------------|----------------------------|--|---|----------------------------|-------------|--|----------------------------|
| FENCE AND ASSOCIATED PARTS | | | BASE AND ASSOCIATED PARTS | | | X-125 | 5/16-24 x 3/4 Soc. Hd. Set Screw . Cup Point | \$0.10 |
| 18434 | Fence Angle Washer | \$ 0.15 | 21130 | Depth of cut pointer assembly | \$ 0.60 | X-205 | 5/16-18 x 3/4 Hex. Head Screw | 0.10 |
| 21140 | Sliding Guard and Hinge Assy. | 1.25 | 21211 | Base | 35.00 | X-212 | 5/16-18 x 1 1/4 Hex. Head Screw | .10 |
| 21150 | Protractor & Scale Assy. | 2.15 | 21212 | Front Foot | 3.50 | X-217 | 5/16-18 x 1/2 Hex. Head Screw | .10 |
| 21221 | Fence Slide | 3.50 | 21213 | Rear Foot | 3.50 | X-232 | 5/16-18 x 1 3/4 Hex. Head Screw | .10 |
| 21311 | Fence | 10.00 | 21214 | Arbor Mounting Bracket L.H. | 3.75 | X-239 | 3/8-16 x 1 1/4 Hex. Head Screw | .10 |
| 21414 | Fence Angle Lock Nut | .50 | 21215 | Arbor Mounting Bracket R.H. | 3.75 | X-420 | 1/2-20 Hex. Nut | .10 |
| 21415 | Fence Adjusting Wrench | 1.75 | 21611 | Leveling Stud | .35 | X-450 | 1/2-13 Hex. Jam Nut | .10 |
| 21416 | Sliding Guard Knob | .65 | 21612 | Cutter Head Leveling Stud | .25 | X-511 | No. 10-24 x 3/8 Round Head Screw | .10 |
| 21619 | Fence Angle Lock Stud | .50 | 21613 | Arbor | 1.50 | X-517 | 1/4-20 x 3/8 Round Head Screw | .10 |
| 21621 | Fence Slide Lock Bolt | .70 | 21614 | Table Elevating Screw | .75 | X-539 | No. 10-24 x 1/4 Rd. Head Screw | .10 |
| 21622 | Sliding Guard Washer | .15 | 21624 | Washer | .15 | X-549 | No. 12-24 x 5/16 Round Head Screw | .10 |
| 21725 | Fence Angle Pointer | .15 | 21711 | Depth of cut gage | .75 | X-550 | 1/4-20 x 1 1/4 Fil. Head Screw | .10 |
| TABLES AND ASSOCIATED PARTS | | | 21712 | Front Cover | 2.50 | X-551 | 5/16-18 x 1 Fil. Hd. Machine Screw | .10 |
| 21010 | Front Table Assembly | 1.50 | 21714 | Arbor Spacer | .15 | X-605 | 9/32 I.D. Lock Washer | .10 |
| 21105 | Linkage Assembly | 2.00 | 21715 | Bearing Pre-loading Spring | .15 | X-608 | 13/64 I.D. Lock Washer | .10 |
| 21170 | Swinging Guard Assembly | 3.50 | 21716 | Felt Washer | .15 | X-611 | 11/32 I.D. Lock Washer | .10 |
| 21216 | Rear Table | 8.00 | 21717 | Bearing Cover | .50 | X-616 | 25/64 I.D. Lock Washer | .10 |
| 21218 | Upper Dovetail | 3.25 | 21718 | Belt Cover | 1.20 | X-625 | 17/64 I.D. Flat Washer | .10 |
| 21219 | Lower Dovetail | 3.00 | 21719 | Swinging Guard Pin Support | .15 | X-675 | 33/64 I.D. Lock Washer | .10 |
| 21412 | Swinging Guard Insert | .75 | 18024 | Hubless V Pulley 2" Dia., 5/8" Bore | .60 | X-1403 | 5/32 Allen Wrench | .15 |
| 21418 | Fence Guide Bar Spacer (Front) | .25 | 18111 | Cutter Head | 12.50 | X-1802 | No. 4 x 1/4 Sheet Metal Screw | .10 |
| 21419 | Fence Guide Bar Spacer (Back) | .25 | 18112 | Cutter Blade | 1.75 | X-2424 | 5/16 I.D. x 3/8 O.D. Ext. Int. Lock Washer | .10 |
| 21422 | Dovetail Spacer | .30 | 18113 | Cutter Blade Wedge | .50 | X-2951 | No. 6-32 x 1/4 Self Tapping Screw | .10 |
| 21616 | Fence Guide Bar | 2.00 | 18211 | Bearing | 1.80 | | | |
| 21617 | Sliding Guard Rod | .55 | 18430 | Collar Assembly | .35 | | | |
| 21721 | Swinging Guard Spring Bushing | .15 | 18600 | Handwheel Assy. | 7.00 | | | |
| 21811 | Swinging Guard Spring | .15 | | | | | | |
| 21812 | Dovetail Tension Plate | .25 | | | | | | |
| | | | THE FOLLOWING PARTS ARE STANDARD AND CAN BE PURCHASED LOCALLY | | | | | |
| | | | X-121 | 5/16-24 x 3/4 Soc. Hd. Set Screw Full Dog Point | \$0.10 | | | |

This sheet is intended for instruction and repair parts only and is not a packing slip. The parts shown and listed may include accessories not necessarily part of this tool. All parts are shipped prepaid. All prices are subject to change without notice.