

INSTRUCTIONS AND PARTS LIST FOR ATLAS No. 73 DRILL PRESS-FLOOR MODEL CATALOG NO. 73

DESCRIPTION

When unpacking, be very careful to go through all papers thoroughly so as not to miss any parts.

MOUNTING MOTOR

A $\frac{1}{3}$ or $\frac{1}{2}$ H.P. 1740 R.P.M. ball bearing motor is recommended to operate this drill press.

Mount the motor on the motor bracket and place the pulley on the shaft with the large step away from the motor. Line up the motor pulley with the spindle pulley by means of a straight edge.

The motor should rotate in a clockwise direction when viewed from the pulley end. If an Atlas motor is being used and it rotates in the wrong direction, reverse according to instructions as shown in Figure 3. If another motor is used, follow manufacturers' instructions.

The drill press does not necessarily have to be secured solidly to the floor, but should stand on a level place.

Before using, lubricate the drill press thoroughly at all places designated on the lubrication chart. See chart under Lubrication.

ADJUSTMENTS AND CONTROLS

(1) To move drill press head or table to a different position on the column, loosen the clamp by turning the lever which is located next to the column.

(2) The quill is locked in position by turning the small lever located at the lower front part of the head.

(3) The two knurled nuts on the spindle stop gauge can be set at any desired position and locked. In this way a definite amount of spindle travel can be obtained and any number of holes can be drilled to a desired depth. The depth gauge is graduated from 0"-4" in $\frac{1}{16}$ " divisions.

(4) Spindle Adjustment—If longitudinal play develops in the spindle it may be eliminated as follows: (1) Remove the two lock nuts on the feed stop bracket, (2) remove spring housing by loosening the set screw on the underside of the boss, (3) remove feed lever and pinion shaft after loosening the set screw in the collar adjacent to the head, (4) pull spindle and quill downward and remove from drill head, (5) loosen set screw in collar directly above the quill and while forcing the spindle up against the bottom of the quill, tighten the collar up against the inner race of the quill bearing. **DO NOT MAKE THE ADJUSTMENT TOO TIGHT.** (6) Put spindle back into drill head and reassemble.

(5) To Remove Chuck from Spindle — See Figure 4. Use the wedge provided for this purpose.

IMPORTANT—Never abuse your drill press chuck. Do not strike it with a hammer, bump it, or drop it at any time. Use the wrench furnished with the chuck.

(6) To adjust tension on Quill Return Spring—Turn the spring housing counterclockwise to increase the tension. To release the tension, pull upward on the ratchet pawl knob.

(7) Table Adjustment—To tilt the table, pull out the knurled handle located directly beneath the table. If the table is tilted 90 degrees right or left the knurled pin can be inserted in the holes provided. For any intermediate angle the table must be locked in place by tightening the nut.

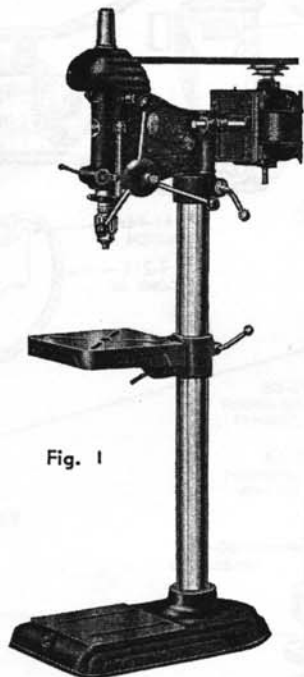

Fig. 1

Should the following replacement ever become necessary, the following installation procedure should be followed:

(1) QUILL BUMPER REPLACEMENT:—

a. Remove the spindle-quill unit from the head as described under section 4 of "Spindle adjustment."

b. Remove old bumper and force new bumper into position by means of a long, slim rod. Make sure the bumper seats itself properly before re-installing the spindle quill unit into the head.

SPEEDS

With a 1740 R.P.M. motor the following speeds will be obtained: (1) With the spindle and motor pulley in direct line—580, 1300, 2440 and 5200. (2) With the motor and pulley raised one step—760, 1800 and 4000 R.P.M. (3) With the motor and pulley lowered one step—1000, 1800 and 3300.

DRILLING

The proper speed for drilling depends upon: 1. The material to be drilled; 2. the size of the hole; 3. the kind of drill. Generally speaking, the harder the material and the larger the drill, the slower should be the speeds.

Make sure that the drill runs true when starting—it may be necessary to countersink the work. Small drills should be fed into the work carefully since they are designed to be run at very high speeds. Avoid too high a speed, especially with the larger drills—excessive speed wears off the drill corners, draws the temper of the drill, and may even burn or break the drill tip.

Note: When drilling brass, aluminum, lead and other soft materials which cause the drill to "hog-in", reduce the rake angle of the cutting edge by grinding the drill as shown in Fig. 5. This reduced rake angle is also desirable when drilling very hard materials because it lessens the strain on the drill. This change makes drilling easier and results in a more accurately drilled hole.

Lubrication: A cutting compound is essential when drilling practically any metal. The following compounds will give best results:

- Hard, tough steels—turpentine or kerosene.
- Softer steels—lard oil or equivalent.
- Aluminum and other alloys—kerosene.
- Brass—drill dry or use paraffin oil.
- Die castings—drill dry or use kerosene.
- Cast iron—drill dry.

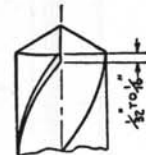

Fig. 5

Do not attempt to make large holes in a small piece or in thin material without first clamping the work securely to the table. For maximum accuracy, raise the table high enough so that the spindle does not run entirely out of the quill in going through the work. When drilling the larger holes, much better results are obtained by using our new slow-speed attachment shown in Fig. 6. This attachment provides a low speed of 200 R.P.M. It can be attached or detached in less than two minutes.

DRILLS: After the drill point is dulled for the first time, its effectiveness depends entirely upon how it is reground. For clean accurate drilling, the operator must resharpen the drill properly. The cone-shaped surface at the end of the drill is called the "point", and the edge at the extreme tip end is the "dead center."

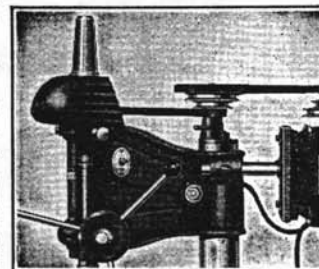

Fig. 6

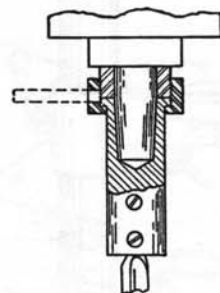

Fig. 2

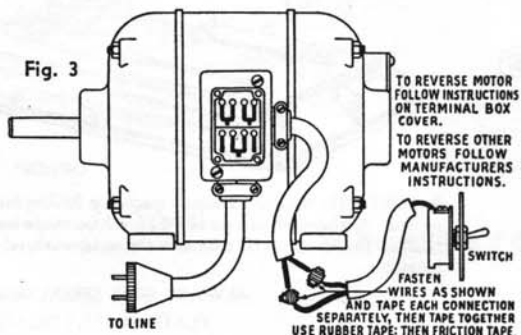

Fig. 3



Fig. 4

(Continued on page 4)

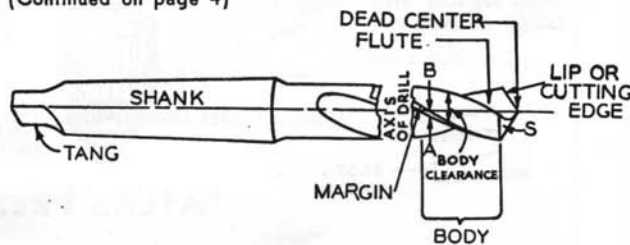
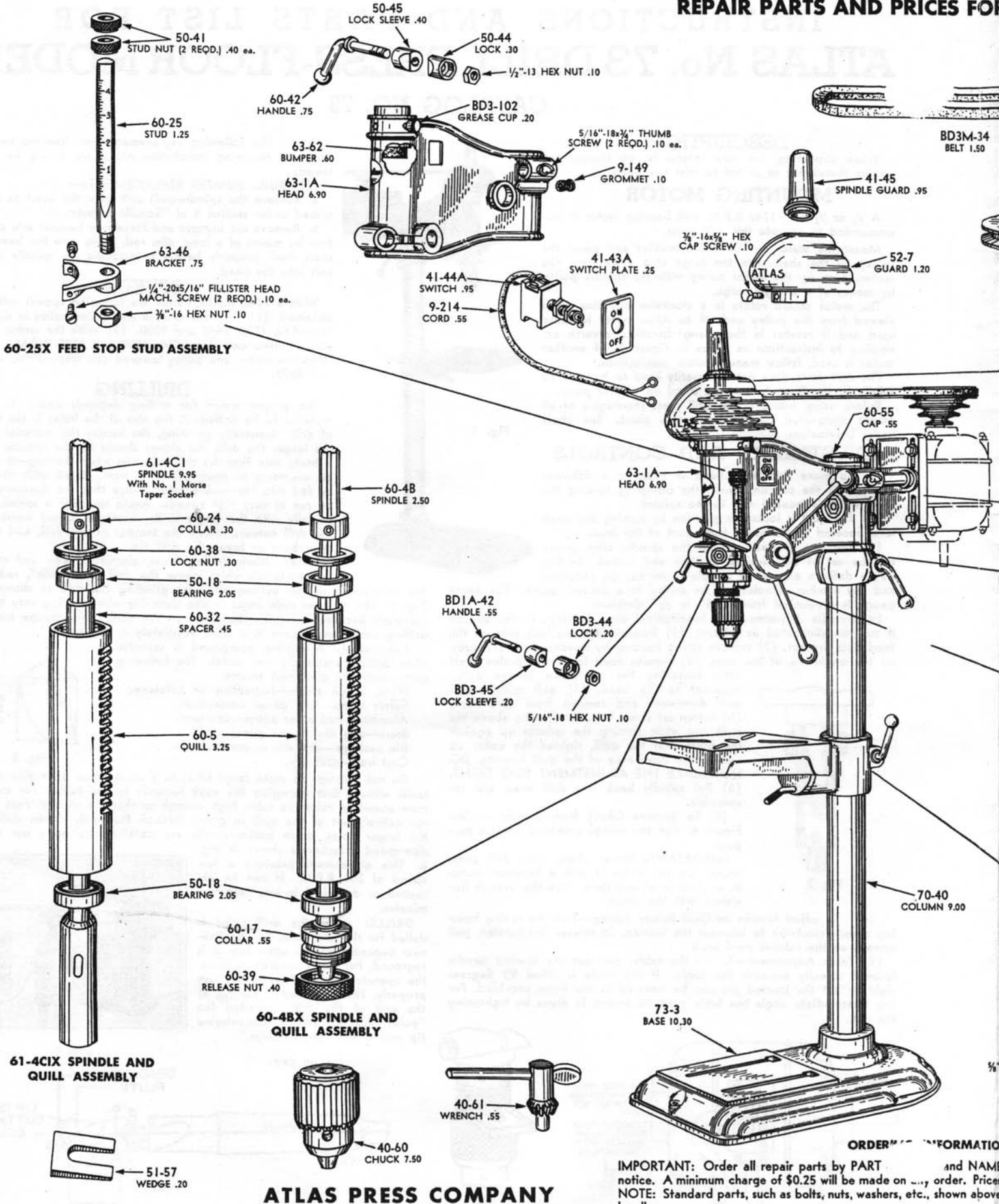

Fig. 7

REPAIR PARTS AND PRICES FOR



ORDER INFORMATION

IMPORTANT: Order all repair parts by PART and NAME and notice. A minimum charge of \$0.25 will be made on any order. Prices NOTE: Standard parts, such as bolts, nuts, washers, etc., shown above locally.

ALWAYS GIVE SERIAL AND MODEL NUMBER AND NAME OF PLATE. PLATE LOCATED ON BASE OF

ATLAS No. 73 DRILL PRESS

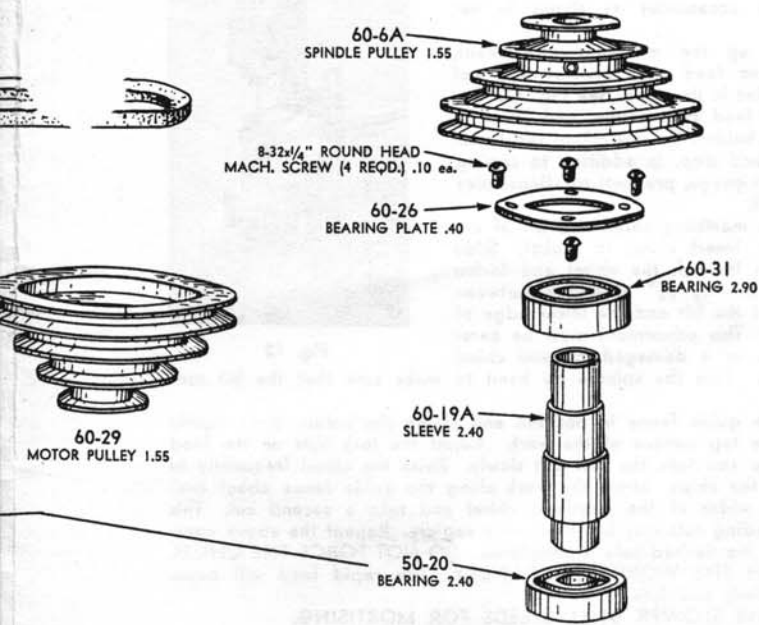

60-6AX SPINDLE PULLEY ASSEMBLY

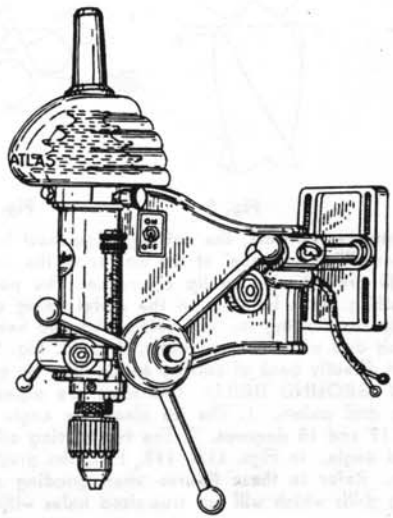

63-IV DRILL PRESS HEAD ASSEMBLY..\$38.00
FURNISHED COMPLETE AS SHOWN WITH CHUCK, MOTOR MOUNTING BRACKET, BELT, PULLEY, AND SWITCH; LESS MOTOR AND COLUMN

63-IZ DRILL PRESS HEAD ASSEMBLY..\$38.00
FURNISHED COMPLETE WITH NO. 1 MORSE TAPER, MOTOR MOUNTING BRACKET, BELT, PULLEY, AND SWITCH; LESS MOTOR AND COLUMN

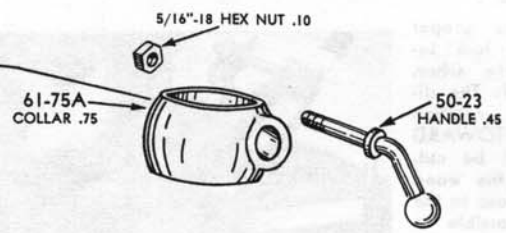

61-75B COLUMN COLLAR ASSEMBLY

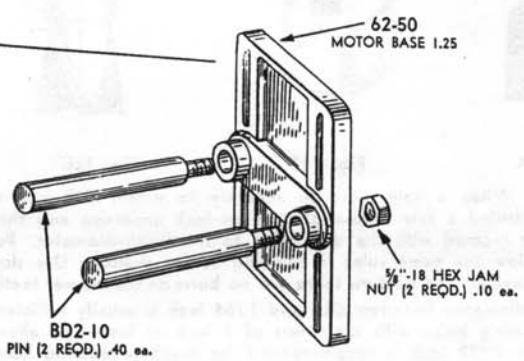

62-50X MOTOR BASE ASSEMBLY

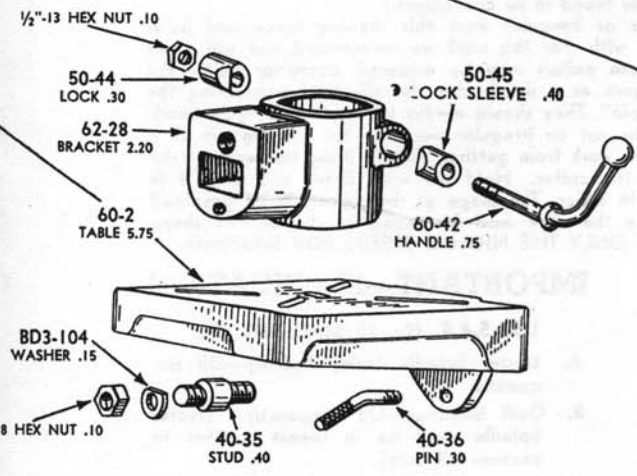

60-2X TABLE ASSEMBLY

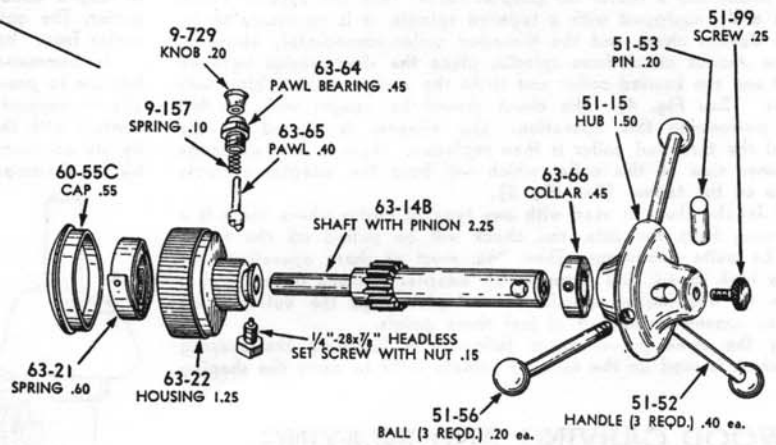

63-148X SPINDLE FEED ASSEMBLY

ON
ME. are subject to change without
es do not include postage or express charges.
re without part numbers should be purchased

KALAMAZOO 13D, MICHIGAN, U.S.A.

NUMBERS STAMPED ON
OF DRILL PRESS.

OPERATING INSTRUCTIONS

MORTISING

Use the hollow chisel mortising attachment and accessories as shown in our catalog.

To set up the mortising attachment, first remove feed stop bracket and put chisel socket in its place. See Fig. 12. Remove the feed stop gauge, and insert in the chisel holder. Do not clamp too tightly. This feed stop, in addition to serving as a depth gauge, prevents rotational play in the quill.

Select a mortising chisel and bit of desired size. Insert chisel in socket. Slide the bit up through the chisel and fasten in chuck, leaving $\frac{1}{8}$ " clearance between the spur of the bit and the lower edge of the chisel. This adjustment must be carefully made or a damaged bit and chisel will result. Turn the spindle by hand to make sure that the bit runs freely.

Set the guide fence in position and clamp the holder down lightly against the top surface of the work. Adjust the lock nuts on the feed stop gauge and take the first cut slowly. Raise the chisel frequently to discharge the chips. Move the work along the guide fence about two-thirds the width of the mortising chisel and take a second cut. This and succeeding cuts may be taken more rapidly. Repeat the above operation until the desired hole is completed. **DO NOT FORCE THE CHISEL THROUGH THE WORK TOO RAPIDLY.** Too rapid feed will cause burned chisels and bits.

USE THE SLOWER DRILL SPEEDS FOR MORTISING.

SHAPING

The head may be used in the normal position as shown in Fig. 13 or inverted. Use the special extension table and spring clips listed in our catalog. When the drill is equipped with a tapered spindle, a special shaping adapter is mounted on the spindle and held by the collar above the chuck. Be sure to use the collar to hold the shaping adapter in place. See "Caution".

Select the proper cutters and lock securely on the arbor. **IMPORTANT:** The direction of rotation should be TOWARD the work to be cut. Always set the wood facings as close to the cutter as possible to secure maximum safety. To feed work from the opposite side: 1. Turn cutter or cutters over. 2. Reverse direction of rotation of spindle. 3. Place hold-downs on opposite side. (A reversing switch will be found to be convenient.)

In shaping circular or irregular work this shaping fence and hold-downs are dispensed with. For this work we recommend and sell a set of depth collars. These collars may be mounted above or below the cutter. The collars serve as a depth stop for the work preventing the cutter from "hogging-in". They should always be used on irregular work.

In commencing the cut on irregular work use the starting pin as a fulcrum to prevent the work from getting caught. Bring the work gradually in contact with the cutter. Hold the work firmly and keep it in contact with the depth collar. The shape of the piece will be governed by its contour; hence the work must be sawed to the desired shape before shaping. **USE ONLY THE HIGHER SPEEDS FOR SHAPING.**

IMPORTANT—LUBRICATION

USE S.A.E. No. 20 MACHINE OIL

- Upper Spindle Pulley Bearing—Oil frequently.
- Quill Bearings—Oil frequently. (Note: Spindle must be in lowest position to uncover oil hole).
- Pinion Shaft Hub Bearing — Oil occasionally.
- Lower Quill Bearing—Oil frequently.
- Lower Spindle Pulley Bearing—Fill grease cup with Lubrico M-6 Grease every three months.

Quill Surface—Oil should frequently be applied to the outside surface of this quill. The spindle cap should be removed frequently and oil applied to the splined spindle also.

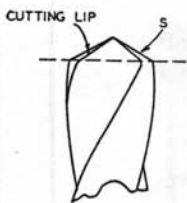

Fig. 8

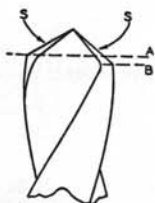

Fig. 9

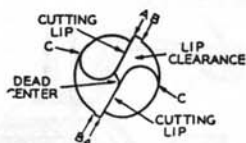

Fig. 10

In order to penetrate the work, the cutting edge must have the correct cutting angle and "lip clearance" at the center of the drill (Fig. 10). Fig. 8 shows a drill ground with no lip clearance. The portion of the drill behind the cutting lip is bearing on the metal being cut and prevents the cutting lip from biting in. The cutting lip and heel "S" are in the same plane. This drill will cut very poorly, if at all. Fig. 9 shows how the "heel", the part directly back of cutting angle, must be ground away.

THE PROPERLY GROUND DRILL: Two rules are especially important when grinding drill points. 1. The lip clearance angle (Fig. 11A) should be between 12 and 15 degrees. 2. The two cutting edges must be of equal length and angle. In Figs. 11A, 11B, 11C, the properly ground drill point is shown. Refer to these figures when grinding a drill—they will aid in grinding drills which will cut true-sized holes with a minimum of drill wear.

We manufacture and sell a drill grinding attachment which is a great aid for grinding drills. (Cat. No. W30.) Any drill between $\frac{3}{32}$ and $\frac{1}{2}$ inch can be ground accurately with this attachment with a minimum of waste to the drill. (See catalog for full information).



Fig. 11A



Fig. 11B

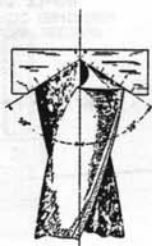

Fig. 11C

REAMING: When a hole must be accurate to within .002 inch or less, it is first drilled a few thousandths of an inch undersize and then hand-reamed or reamed with the drill press to the finish-diameter. For best results, follow the same rules in reaming as for drilling. Use slow speeds, feed in evenly and be sure there are no burrs on the reamer teeth.

A reaming allowance between .010 and $\frac{1}{64}$ inch is usually sufficient for machine-reaming holes with diameters of 1 inch or less—an allowance of $\frac{1}{64}$ or $\frac{1}{32}$ inch is recommended for machine-reaming holes between 1 and 2 inches in diameter. .003 to .005 inch is usually allowed for hand reaming operations.

CAUTION! In using the drill press for any purpose other than drilling, it is necessary to make use of special chucks and adapters.

In using the various types of mortising bits, router bits, etc., the operator **MUST** use a router bit adapter rather than the Jacobs' chuck. On those drills, equipped with a tapered spindle, it is necessary to remove the Jacobs chuck and the threaded collar immediately above it. To remove Jacobs chuck from spindle, place the steel wedge between the chuck and the knurled collar and strike the wedge a sharp blow with a hammer. (See Fig. 4). The chuck should be caught with the left hand in performing this operation. The adapter is placed on the taper, and the threaded collar is then replaced. There is a small flange on the inner side of this collar which will hold the adapter securely in position on the taper. (See Fig. 2).

If the Jacobs chuck is used with any type of cutter where there is a thrust coming from the side, the chuck will be pulled off the taper. This can be quite dangerous. Then, too, most of these operations are done at a high speed, and a router bit adapter is much lighter and is preferable for the higher speed. The adapter grips the cutter shank all the way around instead of at just three points.

Exactly the same procedure is followed in installing the shaping adapter which is used on the tapered spindle drills to carry the shaping cutters.

WOOD CARVING AND INLAYING

For this work, use the special router or woodcarving bits shown in our catalog. The drill press should run at a speed of about 5,000 R.P.M. or higher. Hold the piece to be worked firmly in one hand and run the bit into the work the proper depth. Clamp the spindle securely at this point. Now holding the work with both hands, guide it through the desired design. Frequently, in carving, the work is guided by a jig saw pattern cut out of plywood. This pattern is fastened to the underside of the work itself. A prong pin projecting up from the table runs in the pattern and guides the work.

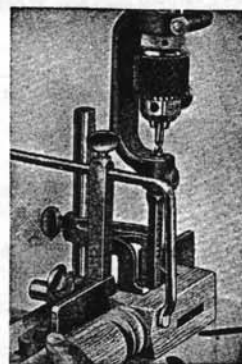

Fig. 12

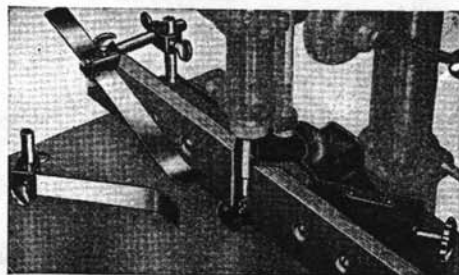

Fig. 13

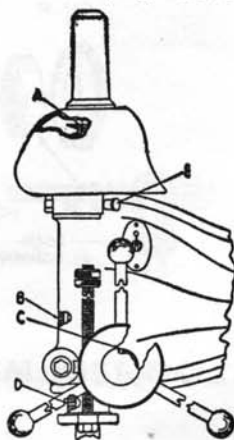

Fig. 14